

Chapter 3

3 Vulnerability assessment methods

3.1 Introduction

In this chapter, several methodologies for seismic vulnerability assessment of buildings are presented. Basically, three methodologies are explained: the (Italian) Vulnerability Index Method, based in Vulnerability Functions, obtained from the relationship between a vulnerability index and observed damage for a building typology, and two other methodologies recently developed by the RISK-UE WP4 Project, the LM1 and the LM2 methodologies, which are based, respectively, in Building Typology Matrices related to Damage Probability Matrices (from observed damage), and to Capacity Spectra and Fragility Models (from numerical models). Forwardly, a discussion on the methodologies selected for use in this research is performed.

3.2 The (Italian) Vulnerability Index Assessment Method (IVIM)

The *Vulnerability Index Method* is a score methodology that punctuates buildings based in eleven assessed parameters. The detection of these parameters, as well as the score assignment for each of them are the results of post-earthquake surveys by means of the “First Level Assessment Form” (“Scheda Di 1° Livello di Rilevamento Danno, Pronto Intervento e Agibilità per Edifici Ordinari Nell’emergenza Post-Sismica”) [GNDT, 2001a].

The process of vulnerability functions build-up is performed by means of the first level assessment form, and the observed damage in buildings due to the occurrence of a seismic event identified by the Intensity degree. The first level assessment form is used to assign an index to the buildings, called the vulnerability index, the observed damage state occurred in buildings due to the occurrence of an earthquake (identified by its macroseismic intensity degree) is also assessed by a damage index (describing the level of physical degradation), finally, the relationship between the vulnerability index, and the damage index for different earthquakes, render the vulnerability functions.

The assessment method is based on visual observations of buildings to identify the primary structural system and its intrinsic significant seismic related deficiencies collected through field surveys of damage. These deficiencies are summarized into an Index, where each of the eleven parameters are scored and weighed for each of the buildings.

In Chapter 2 (State of the Art), the eleven parameters, for Reinforced Concrete buildings, were identified, but not described. The GNDT (Gruppo Nazionale per la Difesa dai

Terremoti) uses the “Second Level Assessment Form (Reinforced Concrete)” (“Scheda di Vulnerabilità di Secondo Livello (Cemento Armato)”) [GNDT, 2001b] in ANNEX B, to survey buildings and assign a Vulnerability Index, where these parameters are described and a qualification (from A, less vulnerable to C, most vulnerable) is established for punctuation.

3.2.1 Second Level Assessment Form (Reinforced Concrete)

The second level assessment form describes the eleven parameters used to identify the primary structural system and its intrinsic significant seismic related deficiencies, and the qualification criteria for each of the parameters. The parameters are:

1. **Resisting System Type and Organization:** this parameter describes the characteristics of the structural system of the building, defining it as the system absorbing more than the 70% of the seismic action. The score is assigned by the following criteria (Figure 3.1):
 - A. Building with a resisting system formed by reinforced concrete walls or by a combination of reinforced concrete frames with masonry walls that comply with all of the following requirements:
 - i. Masonry walls are made of consistent elements, such as solid or semi-solid bricks, precast blocks or well-cut rock blocks, bond together with a quality mortar.
 - ii. Openings in masonry walls do not represent more than 30% of the total wall surface, ($ab < 0.3 h L$)
 - iii. The slenderness ratio for the walls (height/thickness) is less than 20, ($h/e < 20$).
 - iv. The vertical separation between the beam top and the wall top is less than 1.0 cm, ($f < 1.0$ cm).
 - v. The wall overhang from the frame must be less than 20% of wall thickness, ($s < 0.2 e$).
 - vi. Column area must be 25 times greater than wall thickness (in cm), ($c d > 25 e$).
 - vii. Shear *stress* capacity of walls must be greater or equal to 30-35 T/m².
 - B. Building with concrete frames and masonry walls not compliant with A, but matching the following requirements:
 - i. Openings in masonry walls not exceeding 60% of total wall surface, ($a b < 0.6 h L$)
 - ii. The slenderness *ratio* for walls (height/thickness) is less than 30, ($h/e < 30$).
 - iii. The wall overhang from the frame must be smaller than the 30% of wall thickness, ($s < 0.3 e$).
 - iv. Distance between wall top and beam top is less than 3.0 cm, ($f < 3.0$ cm).
 - v. Column area limiting the wall must be greater than 20 times wall thickness (in cm), ($c d > 20 e$).
 - vi. Shear *stress* capacity of walls must be greater or equal to 15-20 t/m².
 - C. Building not complying requirements in A or B.

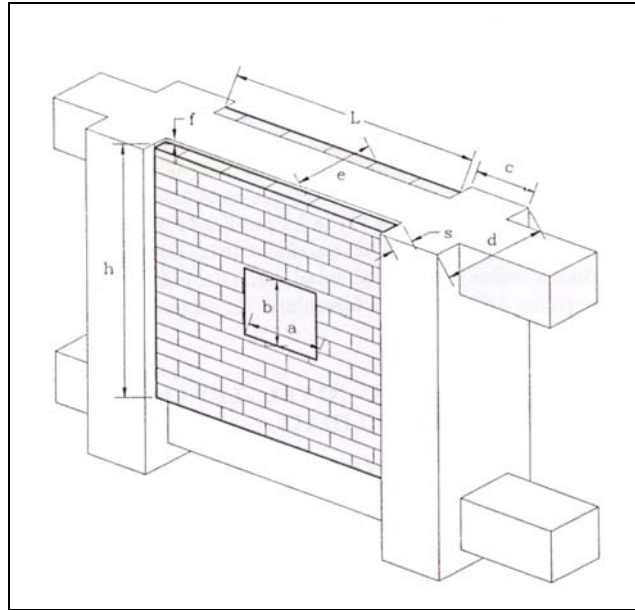

Figure 3.1: Dimensions for the evaluation of Resisting System Type and Organization [Yépez, 1996].

2. **Resisting System Quality:** evaluates the quality of the resisting system with criteria pertaining to construction materials, workmanship characteristics and execution quality. For this purpose, several constructive details are studied and compared to those in the building. Qualifications are assigned by means of completing the following questionnaire:
 - A. Building with the following characteristics:
 - i. Concrete in the structure presents a good consistency, with scratch resistance, where a well execution is observed. Irregular zones with excessive porosity are not verified.
 - ii. Reinforcing steel bars are corrugated (deformed) and are not observed in the surface of the structural elements (sufficient covering of steel).
 - iii. Masonry walls are built with consistent elements in good shape, bonded with a quality mortar. The mortar presents no degradation and is scratch-resistant.
 - iv. The available information about the structure eliminates the possibility of a deficient construction procedure or a low quality workmanship.
 - B. Building with characteristics not complying A or C qualification.
 - C. Building with at least two of the following characteristics:
 - i. Low quality concrete.
 - ii. Reinforcing bars are visible in member surface, rusted or inadequately distributed in the structural member.
 - iii. Construction joints are deficiently built.
 - iv. Masonry walls present a low quality.
 - v. Low quality of constructive and execution processes.
3. **Conventional Resistance:** evaluates, through simplified calculations, the ratio between the acting base-shear and the resistant base-shear of the structure. The acting base-shear is defined through the elastic response spectrum, while resistant base-shear is based in the structural system shear resistant capacity. Being F the reference seismic force at level n , it may be calculated through the expression:

$$F = 0.4R W_i h_i \frac{\sum_{i=1}^n W_i}{\sum_{i=1}^n W_i h_i} \quad \text{eq. 3.1}$$

Where, W_i and h_i are the weight and height of level i , respectively. This result has been obtained by assuming a single (first) mode whose shape (modal vector) is linear. R is the spectral ordinate defined as:

$$R = R_0, \text{ if } 0 \leq T \leq T_0 \quad \text{eq. 3.2}$$

$$R = \frac{R_0}{\left(\frac{T}{T_0}\right)^r}, \text{ if } T > T_0 \quad \text{eq. 3.3}$$

Where R_0 , T_0 and r depend on the soil type over which the structure is founded according to the values shown in Table 3.1, and T is the fundamental period of the building. Equation 3.1 corresponds to the plateau (horizontal) zone while equation 3.2 represents a descendant branch.

Soil Type	T_0	r	R_0
Firm Soil or Rock	0.35	2/3	2.5
Average Soil	0.8	2/3	2.2

Table 3.1: Values for parameters defining the spectral ordinate by soil [Yépez, 1996].

The procedure for evaluation of the shear resistance capacity requires the calculation of a dimensionless coefficient α , which represents empirically the ratio between the resistant force and the acting force by the expression:

$$\alpha = \frac{C}{0.4R} \quad \text{eq. 3.4}$$

$$\text{Where, } C = \frac{A_0 \tau}{qN}, \quad q = \frac{A_x + A_y}{A_t} h P_m + P_s, \quad \text{and } A_0 = \frac{\min(A_x, A_y)}{A_t}$$

In the former equations, N is the number of stories, A_t is the total plan area (m^2), A_x , A_y are the total resisting areas in both main directions of the building (m^2), h is the average story height (m), P_m is the specific weight of the elements in the resisting system (t/m^3), P_s is the weight per area unit of the floor system (t/m^2), and τ is the shear resistance of the structural members. This last parameter (τ) is the weighed average of the different values for shear resistance corresponding to each of the materials in the resisting system, by the relationship:

$$\tau = \frac{\sum \tau_i A_i}{\sum A_i} \quad \text{eq. 3.5}$$

Once the coefficient α is evaluated, qualification for the parameter describing the Conventional Resistance of the structure is performed by means of the following categories:

- A. If $\alpha \geq 1.5$, qualification is: A
- B. If $0.7 \leq \alpha < 1.5$, qualification is: B
- C. If $\alpha < 0.7$, qualification is: C

This parameter evaluates the security coefficient referred to the level of the seismic design force, supposing a ductility factor of 2.5 (see equation 3.3) and using simplified

methods such as the static equivalent method for seismic analysis recommended in seismic codes.

4. **Location and Soil Condition:** through visual inspection, this parameter evaluates, qualitatively, the influence of the terrain and the foundation in seismic behavior. The visual inspection is limited to the consistency and the slope of terrain, the possible level differences between foundations and the presence of asymmetrical or unbalanced embankments. Qualification is as follows:
 - A. Building founded over stable soil with a slope lower than 15% or over rock with a slope not exceeding 30%, without asymmetrical or unbalanced embankments.
 - B. Building not complying categorization A or C.
 - C. Building with an insufficient foundation for any kind of soil in the location. Building founded over loose soils with slopes greater than 30% or over rocky soils with slopes greater than 60%. Asymmetrical or unbalanced embankments are observed.
5. **Diaphragms:** the term “diaphragm” identifies horizontal resistance elements that act to transfer lateral forces between vertical resisting elements [Arnold and Reitherman, 1981]. This parameter evaluates the rigidity of the slabs and their connections to the vertical resisting elements. The are the following qualifications:
 - A. Building with rigid slabs, well connected to the vertical resisting elements. These requirements have to be complied by slabs that represent at least the 70% of total plan surface.
 - B. Building not complying with requirements in qualifications A or C.
 - C. Building with (horizontally) flexible slabs and poor connections to vertical resisting elements, also with slabs qualifying as A, but with a surface lower than 30% of total plan area.
6. **Plan Configuration:** this parameter accounts for mass and rigidity distribution of resisting elements, as well as the plan shape of the building. Qualification is based in certain values obtained by the relationships shown in Figure 3.2. The ratios $\beta_1 = a/L$, $\beta_2 = e/d$, $\beta_3 = \Delta d/d$ and $\beta_4 = c/b$ are defined; where a is the smaller side of the rectangle circumscribing the building, L is the greater side of such rectangle, e is the eccentricity between the center of masses (CM) and the center of rigidities (CR), d is the dimension in the most unfavorable direction of the building and b , c are the longitudes of the major “legs” (“wings”) for “H”, “T”, “L” or “C” plan configurations. Once these *ratios* are evaluated, parameter qualification proceeds as follows:

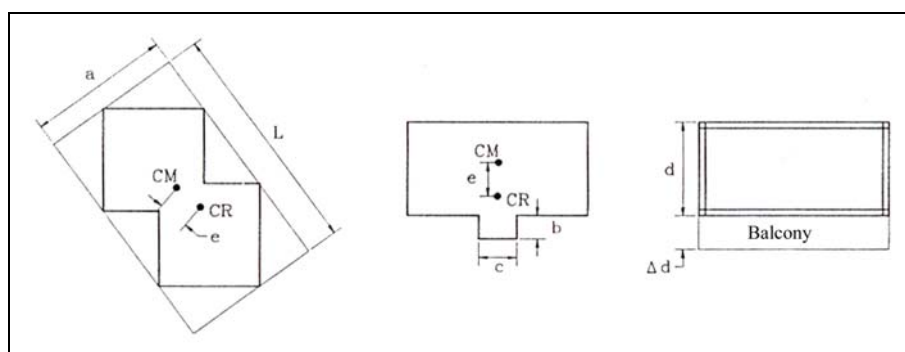

Figure 3.2: Plan Configuration parameters [Yépez, 1996].

- A. Regular plan shape of structure, that complies with all the conditions stated below:
 - i. Ratio β_2 is less than 0.2

- ii. At least 70% of the elements satisfy $\beta_3 < 0.2$
 - iii. Ratio β_1 is greater than 0.4
 - iv. All legs for “T” or “C” plan configurations must satisfy $\beta_4 > 0.5$
 - B. Building not qualified as A or C.
 - C. Irregular plan shape of structure that satisfies at least one of the following aspects:
 - i. Ratio β_2 is greater than 0.4
 - ii. More than 70% of the elements satisfy $\beta_3 > 0.2$
 - iii. Ratio β_1 is lower than 0.2 and more than 30% of the elements verify that $\beta_3 > 0.2$
 - iv. At least one of the legs in “H”, “T”, “L” or “C” configuration verifies that $\beta_4 > 0.25$.
7. **Vertical Configuration:** this parameter considers three basic criteria to evaluate the vertical configuration. The first, accounts for vertical irregularity of the building by the description of vertical setbacks, using the ratio between the total height of the building (H) and the height of the setback (T) (Figure 3.3). The second, compares the factors that quantify mass variations (δM) between successive levels ($\pm \delta M/M$), where M is the mass of the immediate inferior level, or also, the area variation (δA) between successive levels ($\pm \delta A/A$), where A is the area of the immediate inferior level. The third criterion accounts for the variation of the resisting system in height, which might be not variable: as the resisting system is regular in all the building height, or variable: where discontinuities of strength and stiffness in structural elements may appear, as the presence of discontinuous or asymmetrical shear walls (in shape and/or material) and/or the verification of vertical discontinuities of the resisting frame (soft stories). Using these criteria, the method qualifies this parameter through the following instructions:
- A. The building structure has a regular vertical configuration, with no vertical variations in the resisting system. The ratio T/H is lower than 0.1 or greater than 0.9.
 - B. Building that does not qualify as A or C.
 - C. Building with vertical variations in the resisting system, not only pertaining the location of these elements, but also the quantity, quality and type of resistant elements used. Building with a mass increment greater than 20% in two consecutive levels verifying $0.1 \leq T/H \leq 0.3$, or verifying $0.7 \leq T/H \leq 0.9$. Building without vertical variations in the resisting system, but verifying that $0.3 \leq T/H \leq 0.7$ and the mass variation between two successive levels is greater than 40%.

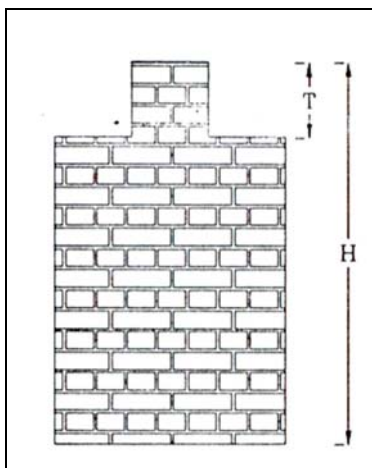

Figure 3.3: Vertical Configuration parameters [Yépez, 1996].

8. **Connectivity between elements:** beam-column or slab-column connections are critical in lateral load transfer and resistance of the structural system; a deficient performance of connection leads to a non-ductile behavior of the structures increasing the possibility of severe damage or collapse. The Italian method considers this issue by means of the evaluation of three different γ factors, defined as:

$$\gamma_1 = \frac{s}{b}; \quad \gamma_2 = \frac{e}{b'_{\min}}; \quad \text{and} \quad \gamma_3 = \frac{e}{b''} \quad \text{eq. 3.6}$$

Where, s is the overhang of a (wide) beam respect to the column, b is the column dimension in that direction, e is the eccentricity between the beam and column axes, b'_{\min} is the smallest value between beam and column width, and b''_{\min} is the dimension of the column perpendicular to the direction of verification (Figure 3.4). The qualifications for this parameter are assigned by:

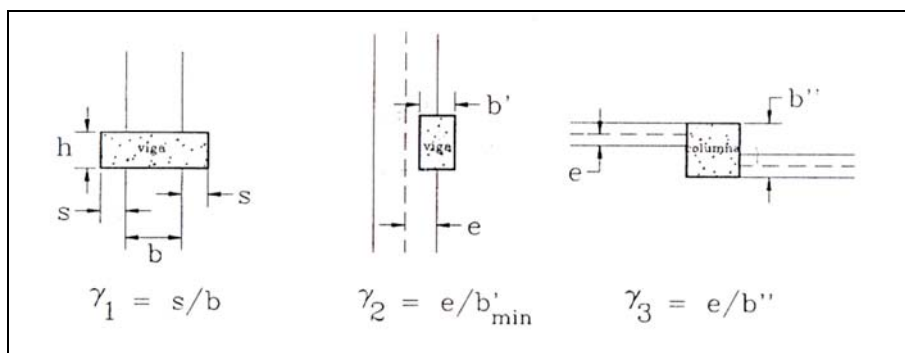

Figure 3.4: Evaluated factors for Connectivity between Elements parameter [Yépez, 1996].

- A. Connections in good conditions, satisfying the requirements:
- $\gamma_1 < 0.2$, $\gamma_2 < 0.2$, $\gamma_3 < 0.3$.
 - The smallest dimension of columns with an average compression stress greater than 15% of its ultimate resistance is greater than 25 cm.
- B. Building with connections not satisfying A or C.
- C. Building with deficient connections, verifying one of the following cases:
- More than 70% of the connections do not satisfy the requirements for A qualification.
 - More than 30% of the connections verify that $s > 0.4b$, $e > 0.3b'_{\min}$ or that $e > 0.4b''$.

- iii. The smallest dimension of columns with an average compression stress greater than 15% of its ultimate resistance is lower than 20 cm.
9. **Low Ductility Structural Members:** this parameter evaluates the presence of low-ductility structural members, by means of identifying their configuration, geometry and location as the ones shown in Figure 3.5. Qualification of buildings is performed by matching the following descriptions:
- A. Buildings without low-ductility structural elements, or those that may not be considered in categorizations B or C.
 - B. Buildings with low-ductility structural elements, verifying one of the following cases:
 - i. The shortest structural member's height is less than half the height of the rest of structural elements (h / H ratio in Figure 3.5).
 - ii. Only one structural element with a height lower than $2/3$ of the rest of elements exists, but possesses a high ductility.

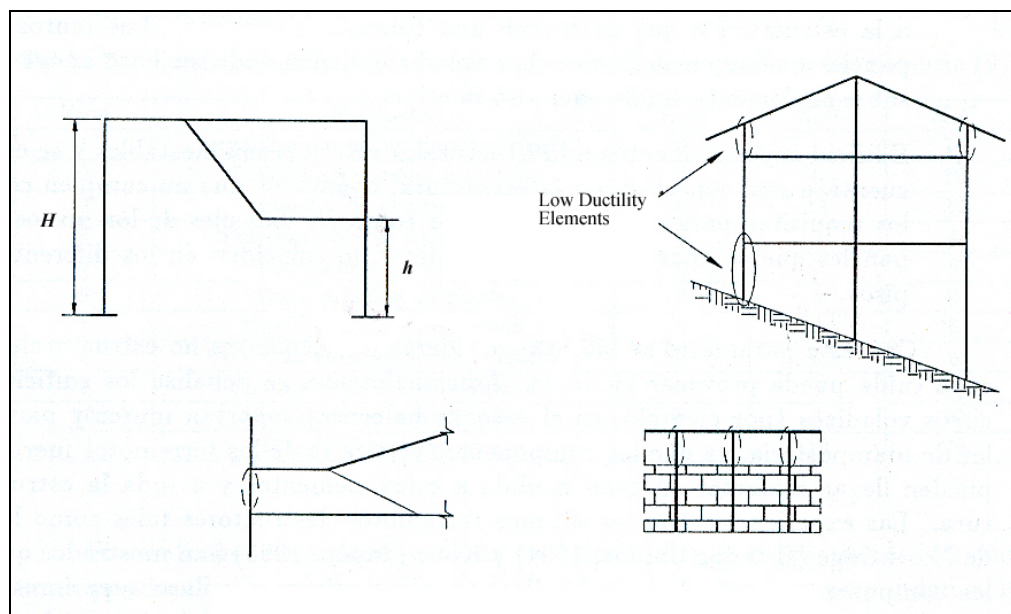

Figure 3.5: Low ductility elements identification, after [Yépez, 1996].

- C. Buildings with low-ductility structural elements, verifying one of the following cases:
 - i. The shortest structural member's height is less than 25% the height of the rest of structural members.
 - ii. Only one structural element with height lower than the half of the rest of elements exists, but requires a high ductility.
10. **Non-structural Elements:** the method classifies non-structural elements as internal (partition walls, furniture, flush ceilings, etc.) and external (antennas, cornices, parapets, masonry walls and panels, chimneys, balconies, etc.); elements that may or may not collapse partial or totally depending on the connection quality to the resisting elements in the structure. Qualification is as follows:
- A. Buildings with external non-structural elements well connected to the resisting system and with internal non-structural elements in stable condition although not connected thoroughly to the resisting system.

- B. Buildings with stable external elements but not connected to the structure, or with a deficient connection. The masonry walls and panels over cantilevers verify that all bases are supported by similar elements in the levels below.
 - C. Buildings with unstable external non-structural elements poorly connected to the structure, or buildings not qualified as A or B. The masonry walls and panels axes over cantilevers do not coincide in the different levels.
11. **Preservation State:** this is a subjective parameter, qualified through a simple visual inspection that may penalize the presence of imperfections in the structure as well as possible irregularities identified as results of a poor construction process. Additionally, imperfections or damage in foundations may be detected. Qualification proceeds by matching the following characteristics:
- A. Buildings with principal resisting elements (beams, columns, slabs, etc.) not appearing fissured (cracked) and with no apparent damage in foundations. The non-structural elements in the building are in good shape, not showing apparent damage.
 - B. Buildings not qualified as A or C.
 - C. More than 30% of principal structural elements present fissures, the slabs are fissured (cracked) considerably (more than 5 mm) and the foundations are damaged.

3.2.2 Vulnerability Index Quantification

The qualifications are chosen by means of the instructions presented in the “Second Level Assessment Form”. Each of the quality grades assigned to a building for a certain parameter is defined by percentages, quantities and descriptions. They necessarily depend on the judgment of the evaluator, whom does not require a high level of expertise, but instead, a basic knowledge of structural concepts.

Once the qualifications for each of the parameters are established (A, B or C), a process of numerical values assignment for each of them and a weighed sum of the eleven parameters is performed. The weighed sum is a critical process in the score assignment, as it multiplies each of the parameters with an importance factor, where the weight values depend on expert opinions. In Table 3.2, the parameters, with the respective qualification and weight are shown for a study performed in Barcelona by Yépez, (1996), which was adapted from a table of the Italian Institute of Seismic Risk (Istituto di Ricerca Sul Rischio Sismico) [CNR, 1993]. As it may be verified, the parameters with different weights are: “Resisting System Type and Organization”, with $W_1 = 4.0$, “Vertical Configuration”, with $W_7 = 2.0$, and “Preservation State”, with a weight $W_{11} = 2.0$. These values are eminently subjective as are the result of expert opinions. The use of the expression for vulnerability index is normalized between values 0 and 100, from least to most vulnerable buildings respectively.

Post-earthquake surveys based in the mentioned eleven parameters, have made possible the construction of vulnerability functions relating the Vulnerability Index of the buildings with the amount of damage observed at certain intensities, for Reinforced Concrete and Masonry buildings. These functions are curves, for each intensity and building type, relating the vulnerability index with an index describing the observed damage level in buildings. Other approaches exist, based not in observations of post-earthquake damage but in damage simulation through modeling, as in the case of the research performed by Yépez, (1996). The vulnerability functions for reinforced concrete buildings were obtained by means of damage simulation by several numerical models, as post-earthquake observations were not available for this typology. The approach used consisted in the random generation (through the Monte Carlo Method) of ten different 3D building models with reinforced concrete structures of two

types: Frame (Column-Beam) and Flat Slab (Column-Flat Slab) structural systems. Each of the simulated buildings was analyzed in the two principal directions by means of a Two-Dimension inelastic seismic damage analysis software (IDARC-2D, “Inelastic Damage Analysis of Reinforced Concrete Structures”) [Reinhorn and Kunnath, 1994]. As input, families of ten artificial accelerograms were used, where each family corresponds to the expected maximum acceleration at the intensities considered in seismic hazard studies for the city of Barcelona in Spain. Results obtained are a series of vulnerability functions, for each intensity and buildings sub-types considered.

In Figure 3.6 and Figure 3.7, the vulnerability functions for Reinforced Concrete Frame Building and RC Flat Slab Building types are shown, respectively. The functions establish a series of relationships between Vulnerability Index and the Economic Damage Index, which represents the structural damage inflicted by an earthquake of certain intensity. It may be noticed how the intensities at which similar damage occurs are one degree of intensity below in the RC Flat Slab building type respect the RC Frame building type, consequently, the first building type is more vulnerable than the second.

Number	Parameter	Qualification			Weight W_i
		K_i			
		A	B	C	
1	Resisting System Type and Organization	0	1	2	4.0
2	Resisting System Quality	0	1	2	1.0
3	Conventional Resistance	-1	0	1	1.0
4	Location and Soil Condition	0	1	2	1.0
5	Diaphragms	0	1	2	1.0
6	Plan Configuration	0	1	2	1.0
7	Vertical Configuration	0	1	3	2.0
8	Connectivity between elements	0	1	2	1.0
9	Low Ductility Structural Members	0	1	2	1.0
10	Non-structural Elements	0	1	2	1.0
11	Preservation State	0	1	2	2.0

Table 3.2: Parameter qualification values for Reinforced Concrete Buildings, [Yépez, 1996].

These vulnerability functions are not susceptible to be applied over other regions different from those in the original studies. The results of vulnerability functions describe the relationship between the vulnerability index and the observed damage occurred, due to the action of a certain earthquake, which responds to damage observations in certain building types that have been previously assessed (with respect to seismic vulnerability). As stated previously in Chapter 2, the vulnerability function of a certain building type depends much on the construction materials quality, construction practice, code compliance, and many other factors that configure this function as a national or regional characteristic of the building type. Thus, a direct usage of the functions relating damage with vulnerability index from other countries with different construction practices is not realistic.

However not useful for damage prospect ion using the existing vulnerability functions, the Italian Vulnerability Index Method provides a detailed description of the building’s seismic deficiencies, which may be used to relate with equivalent building analytical models for damage estimation, as in the case of Yépez, 1996.

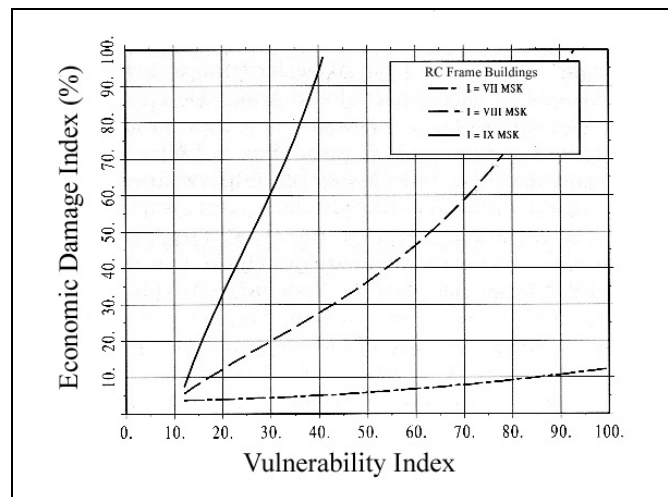

Figure 3.6: Vulnerability Functions for RC Frame Buildings, after [Barbat, 1998].

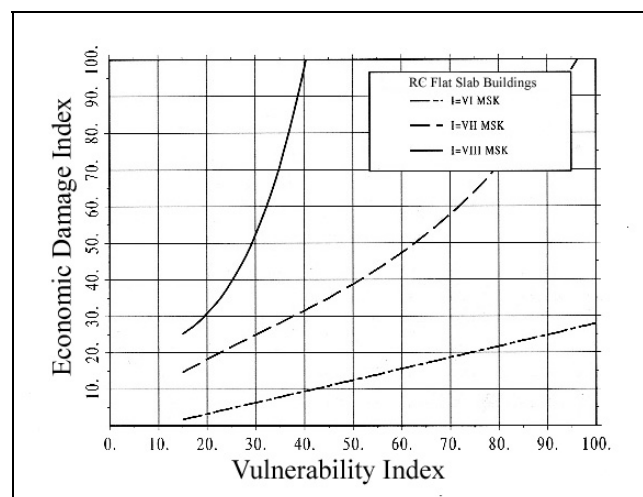

Figure 3.7: Vulnerability Functions for RC Flat Slab Buildings, after [Barbat, 1998]

3.3 Building Typology Matrix based methods

EMS-98 and simplified numerical models. Seismic vulnerability assessment methodologies are varied and account for different approaches depending on the objectives of the study and the availability of data. Actual trends in vulnerability assessment for risk scenario analyses are oriented towards the use of *Building Typology Matrices*, which relate building typologies with damage states considering different approaches to damage estimation through vulnerability-damage relationships of different nature. In this fashion, the most important approaches (due to its wider use in the world) for estimating vulnerability relationships are:

- **Empirical and expert opinion relationships:** approach to vulnerability functions is based on damage data obtained from post-earthquake observations and expert opinions, establishing a typological identification of the buildings and using empirical relationships for the different building typologies' seismic performance. The typologies are defined by descriptions of the construction materials and the structural systems used in the buildings, related to vulnerability classes. These approaches to seismic vulnerability assessment may be applied when the information of the buildings is poor or scarce, as the evaluation of the vulnerability is performed typologically. Within these approaches, the macroseismic scales used to assess

Intensity through the observed effects of an earthquake (where the building seismic damage distribution by typologies is an important descriptor in the scales), may well be used for the prediction of the probable damage distribution in the buildings for an expected earthquake Intensity; this damage distribution forecast is performed by means of the *Damage Probability Matrices*, which describe, for each of the vulnerability classes considered in the scale, the probability of undergoing certain damage states at a given Intensity. Examples of methodologies using this approach are encountered in the European Macroseismic Scale [EMS, 1998] and in the RISK-UE-WP4-LM1 Methodology [Multinovic and Trendafiloski, 2003], where both approaches use the typological identification of the buildings to assess seismic vulnerability, and Damage Probability Matrices to predict the damage in the buildings.

- **Numerical models relationships:** the approach is performed by means of numerical estimation of structural damage. The analyses are performed using simplified mechanical models for the description of building performance (by typology), mostly by means of Capacity Spectra based analysis. The *Capacity Spectra* describe the expected seismic performance of typical buildings, estimating the expected peak response of a building (S_d) at a given demand (S_a) (presented in acceleration-displacement spectral coordinates, known as ADRS: *Acceleration-Displacement Response Spectra*). The seismic input used for the estimation of behavior is the demand spectrum, based in the 5% damped building-site specific response spectrum modified to account for inelastic structural behavior, presented also as an ADRS [Multinovic and Trendafiloski, 2003; Giovinazzi and Lagomarsino, 2004]. The intersections between the Capacity and the Demand curves, for different levels of excitation gives the results of seismic performance of the buildings, and are used to build the *Fragility Curves*, which predict the conditional probabilities of a building of being in, or exceeding, specific damage states at specified levels of ground shaking. These approaches to seismic vulnerability assessment require, for an individual building or a typologically homogeneous building group, information about the structure of the buildings (structural array, structural material properties and building configuration) to elaborate simplified mechanical models. The latter leads to conclude that the required information on the buildings must be detailed, such as the project (blueprints) and the construction information (technical reports of the construction process), or at least the information acquisition should be performed by means of “... *detailed building inventories for selected districts within the study region, in which different forms of irregularity, building construction age and quality, materials used, and so forth, can be recorded and analysed statistically...*” [Lam et. al., 2004]. Examples of Capacity Spectrum methodologies are found in the RISK-UE-WP4-LM2 Methodology [Multinovic and Trendafiloski, 2003], and the HAZUS®99 Methodology [HAZUS-99-SR2, 2002], which consider, within the methodologies for seismic risk assessment in Europe and the USA, respectively, the Capacity Spectrum approaches in the assessment of seismic vulnerability of buildings.

3.3.1 Empirical and expert opinions relationships

The European Macroseismic Scale [EMS, 1998] is a macroseismic intensity assessment method, based in a clear definition of building typologies which uses distributions of damage correlated to each degree of Intensity [Giovinazzi and Lagomarsino, 2004]. This methodology proposes a vulnerability classification in six classes, depending on the behavior of the building typologies when submitted to earthquake action. Such building categories depend on the building materials and the structural system, with four general typologies: Masonry,

Reinforced Concrete, Steel and Wooden Buildings; within them, some structural types are described based on the building's structural material usage and its configuration in the construction (Table 3.3). The structural typologies in the EMS-98 are described in Section 2 (*Vulnerability*) of the EMS-98 Intensity Scale, in Annex A. The *vulnerability classes* range from A to F, from the most vulnerable to the least vulnerable typologies, where the first three classes (A to C) identify adobe house, brick buildings and Reinforced Concrete constructions, and the last three are engineered buildings with incrementing earthquake resistant design procedures.

Type of Structure	Vulnerability Class					
	A	B	C	D	E	F
MASONRY	○					
	○					
	○					
	○					
	○					
	○					
	○					
STEEL REINFORCED CONCRETE (RC)	○					
	○					
	○					
	○					
	○					
	○					
WOOD	○					
	○					

○ most likely vulnerability class; — probable range; - - - range of less probable, exceptional cases

Table 3.3: Classifications used in the European Macroseismic Scale [EMS, 1998].

The building types are classified within a certain vulnerability class where the most likely vulnerability is marked with a circle (○); the range limits are defined with the (|) symbol where probable (—) and less probable (- -) ranges are identified. These ranges exist because vulnerability also depends on other factors such as: quality of workmanship, state of preservation, regularity, ductility, position, strengthening, and earthquake resistant design level. Usefulness of the EMS scale relies in the feasibility to assess large building stocks in extended urban areas due to the low time expenditure in classifying the buildings into vulnerability classes, via a fast survey or by the cadastral data available from local governments.

The categorization of damage grades distribution (from Damage Grade 1 or slight damage, to Damage Grade 5 or destruction, in Table 2.1) for the different vulnerability classes in the interest zone at a given Intensity, which are used for post-earthquake survey and assignment of the Intensity Degree, may be used for the prediction of damage through the generation of vulnerability-damage relationships. The latter relate the damage distribution for each of the vulnerability classes as the probability of occurrence for each of the damage grades, at a certain Macroseismic Intensity Degree in the scale, conforming *Damage Probability Matrices* (DPM). These DPM are built for each of the vulnerability classes and intensities, expressing the probability that the damage grades are reached by the buildings in the analysed stock. An example of a DPM for Vulnerability Class A, from Pujades 2004, is shown in Table 3.4; the

intensities considered are those from $I = V$ to $I = X$. This DPM shows the evolution of the damage states as the intensity degree is incremented, where for intensity $I = V$, the probabilities of occurrence for no-damage (0) and slight-damage (1), are 0.90 and 0.10, respectively, and for intensity $I = X$ the probabilities of occurrence for Heavy (3), Very Heavy (4) and Destruction (5) damage grades are 0.03, 0.22 and 0.75, respectively. The damage increases with the intensity degree where the greater probabilities are concentrated in the damage grades following the descriptions in the scale, for example, the damage to class A buildings for $I = V$ states: “Damage of grade 1 to a few buildings of vulnerability class A ...”, and for $I = X$: “Most buildings of vulnerability class A sustain damage of grade 5 ...” [EMS, 1998].

Damage Grade	Intensity					
	V	VI	VII	VIII	IX	X
None (0)	0.90	0.42	0.04	0.00	0.00	0.00
Slight (1)	0.10	0.40	0.17	0.04	0.01	0.00
Moderate (2)	0.00	0.15	0.32	0.17	0.04	0.00
Heavy (3)	0.00	0.03	0.30	0.33	0.19	0.03
Very Heavy (4)	0.00	0.00	0.15	0.32	0.41	0.22
Destruction (5)	0.00	0.00	0.03	0.13	0.35	0.75

Table 3.4: Damage probability matrix for vulnerability class A buildings, after [Pujades, 2004].

Experiences in the utilization of this approach have had satisfactory results in order to identify vulnerable building type groups in an urban location, allowing the assessment of large urban areas with a short-time consumption feature in this process [Villacís et al., 1998; Chávez, 1998; Pujades et al., 2000; Fähr et. al., 2001]. However useful, the definitions of the quantity of buildings damaged (at a certain Damage Degree) for each of the vulnerability classes (at a given Intensity, which define the Damage Model) are vague, as they are provided through the terms “Few”, “Many” and “Most”, where the percentages of buildings are presented as overlapping intervals (10% overlap) between the three categorizations of damage (Figure 3.8), and incomplete, as the damage quantification in the Scale only considers the most easily and common observable situations. For example, in the Damage Model for Class A (Table 3.5), EMS-98 does not consider the distribution for Damage Grades 3, 4, and 5 for Intensity $I = VI$. The results of damage degrees distribution forecast by means of this Scale are diffuse and introduce scatter in the Damage Probability Matrices, as they depend not only on expert opinions, which implies subjectivity, but also in post-earthquake damage observations, which may introduce scatter by means of the data quality of the field survey, i.e. poor definitions in terms of damage limit states, and errors inherent in the damage classification of the surveyed buildings [Rossetto and Elnashai, 2002].

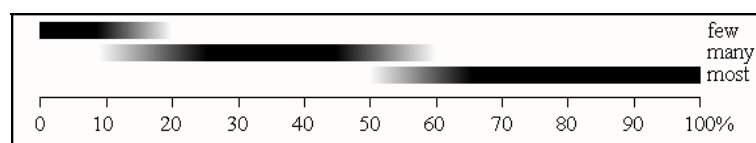

Figure 3.8: Definitions of quantity [EMS, 1998].

Intensity	DG1	DG2	DG3	DG4	DG5
VI	Many	Few			
VII			Many	Few	
VIII				Many	Few
IX					Many
X					Most
XI					
XII					

Table 3.5: Damage quantity matrix for Vulnerability Class A.

A methodology that has overcome this diffuse aspect of the damage distribution in the EMS-98 is the RISK-UE LM1 Methodology [Multinovic and Trendafiloski, 2003; Giovinazzi and Lagomarsino, 2004], which solves the gap of incompleteness and vagueness through the use of a discrete probability distribution of damage grade.

Based in the observations and statistical analyses of the 1980 Irpinia Earthquake, a (discrete) binomial distribution has been identified as the best one fitting the analysed data, however, the simplicity of this distribution, depending on only one parameter, it does not allow defining the scatter of the damage grades around the mean value. This problem is solved by the use of a probability distribution with similar looks, such as the continuous Beta Probability Distribution (with further transformation into a discrete one), which suits better the specific requirements under certain characteristic conditions. The expression for this (Beta) distribution is:

$$PDF : p_{\beta}(x) = \frac{\Gamma(t)}{\Gamma(r)\Gamma(t-r)} \frac{(x-a)^{r-1}(b-x)^{t-r-1}}{(b-a)^{t-1}}, \quad a \leq x \leq b \quad \text{eq. 3.7}$$

$$CDF : P_{\beta}(x) = \int_a^x p_{\beta}(\varepsilon) d\varepsilon \quad \text{eq. 3.8}$$

$$\mu_x = a + \frac{r}{t}(b-a) \quad \text{eq. 3.9}$$

Where a , b , t and r are the parameters of the distribution, μ_x is the mean value of the continuous variable x , which ranges between a and b . Such variable represents in some way the degree of damage. $P_{\beta}(x)$ is the probability of the continuous variable x being in the range between a and x (i.e. the distribution function) while $p_{\beta}(x)$ is the probability density function.

The use of this distribution requires making reference to Damage Grade D , which represents a discrete variable characterized by five Damage Grades (Damage Grade 1 to Damage Grade 5) and also considering the absence of damage (Damage Grade 0); it is advisable then, to assign value 0 to parameter a and value 6 to parameter b . Based in this relation between the continuous variable x and the discrete one D it is possible to estimate the discrete probability p_k associated with a Damage Grade k ($k = 0, 1, 2, 3, 4, 5$) as follows:

$$p_k = P_{\beta}(k+1) - P_{\beta}(k) \quad \text{eq. 3.10}$$

Obviously, the mean damage grade or mean value of the discrete distribution k has the expression:

$$\mu_D = \sum_{k=0}^5 p_k \cdot k \quad \text{eq. 3.11}$$

The mean value of the Beta Distribution (μ_x) can be correlated with μ_D by means of a third degree polynomial:

$$\mu_x = 0.042\mu_D^3 - 0.315\mu_D^2 + 1.725\mu_D \quad \text{eq. 3.12}$$

Then, by equations 3.9 and 3.12 (being $a = 0$ and $b = 6$), the two parameters from the Beta Distribution r and t are correlated with the mean damage grade μ_D as follows:

$$r = t(0.007\mu_D^3 - 0.0525\mu_D^2 + 0.2875\mu_D) \quad \text{eq. 3.13}$$

The parameter t in equation 3.12 affects the scatter of the distribution, if value 8 is assigned to this parameter the Beta Distribution looks very similar to the Binomial Distribution.

The latter solves the incompleteness of the Damage Model in the EMS-98, through a proper discrete Beta probability Distribution of the damage grade, where the parameter t affects the scatter of the distribution. The vagueness of the qualitative terms: “Few”, “Many”, and “Most”, encounters a solution in the WP4-LM1 Methodology, by means of using fuzzy sets theory, which can model the terms as delimited probability ranges, leading to the estimation of upper and lower bounds of the expected damage. This is performed using *membership functions* χ , which define the belonging of single values of a certain parameter to a specific set; where the value of χ are:

- $\chi = 1$, when the degree of belonging is plausible (i.e. credible, almost sure),
- $0 > \chi > 1$, when the degree of belonging is rare but possible; and,
- $\chi = 0$, when the parameter does not belong to the set.

The definitions of the membership functions in the vague zones (overlapping percentages between the terms Few, Many and Most) are performed by means of a straight line (linear interpolation), the plausible values of the parameter μ_D are the ones for which all EMS-98 quantity definitions are plausible; the possible values of parameter μ_D are those for which all EMS-98 definitions are still plausible or possible, with at least one which is only possible (Figure 3.9).

The Damage Probability Matrices may be built based in the latter considerations, for each of the vulnerability classes in the EMS-98 (from A to F) describing the plausible and possible behavior for each of the classes through the (plausible and possible) values of the mean damage grade given an EMS-98 intensity degree; connecting these points, draft curves are drawn defining the plausibility and possibility areas for each vulnerability class (Figure 3.10). At that Figure, each vulnerability class is divided into four levels; for instance, for class A such levels are termed A-- (...), A- (...), A+ (...) and A++ (...).

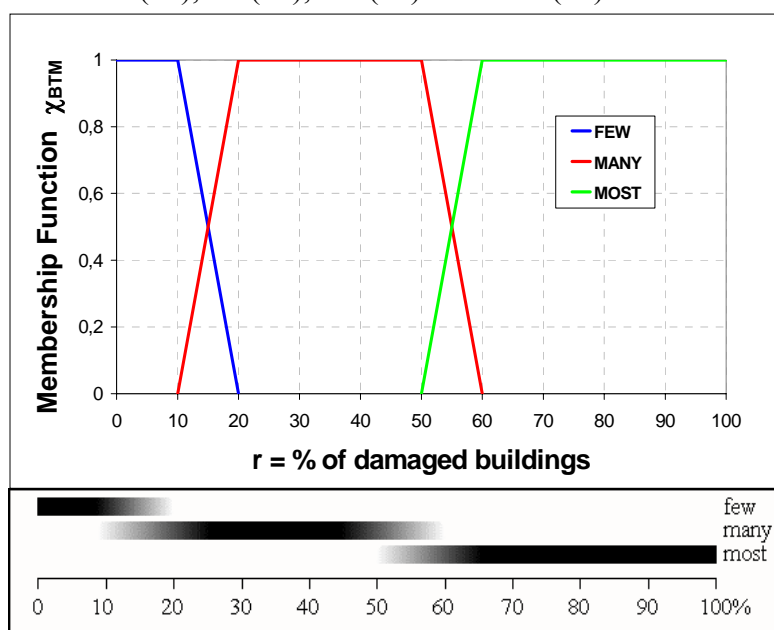

Figure 3.9: Membership functions for the quantities in EMS-98 [Multinovic and Trendafiloski, 2003].

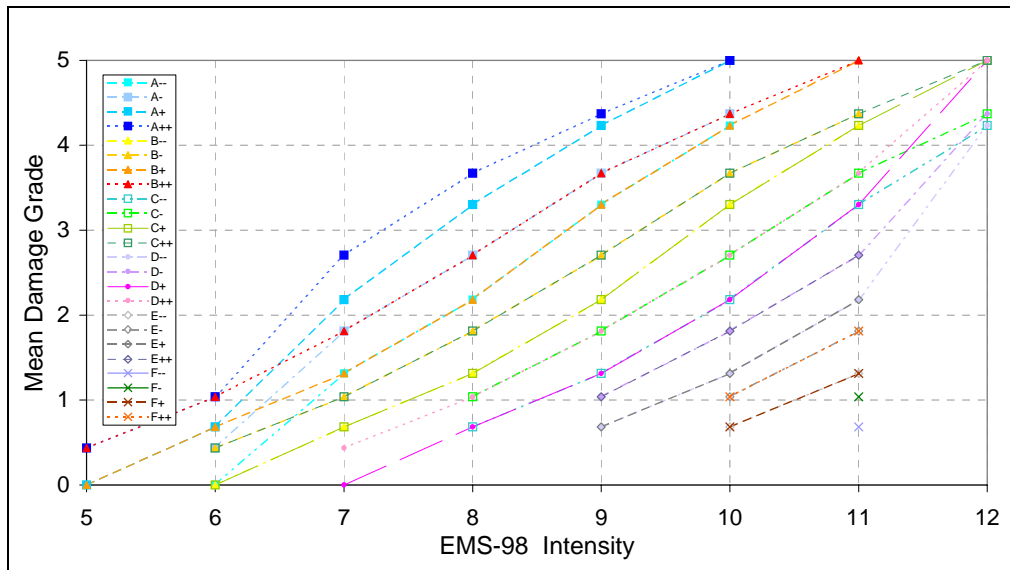

Figure 3.10: Plausible and possible behavior for each vulnerability class [Multinovic and Trendafiloski, 2003].

Another novel contribution of this methodology is centered in establishing the belonging of the buildings to a certain vulnerability class through a *vulnerability index*, which quantifies, by means of an arbitrary score, the seismic behavior of the buildings. This vulnerability index ranges between 0 and 1 from least to most vulnerable. Once again, the Fuzzy Set Theory is used in this case to define membership functions for the buildings to a specific vulnerability class by means of a vulnerability index (V_I), where the membership functions of the six vulnerability classes (from A to F) have a plausible ($\chi=1$) and linear possible ranges, defining the transition between two adjacent classes (Figure 3.11); the membership functions have the same shape and are translated the same quantity, in accordance with the parallelism and the constant spacing between the plausibility-possibility curves in Figure 3.10. The fuzzy definition of these vulnerability indices (see Figure 3.11) assigns:

- The most probable value for each vulnerability class where the membership function is $\chi=1$ (which is defined as V_I^{C*}),
- The bounds of the uncertainty range V_I^{C-} and V_I^{C+} , and,
- The upper and lower bound of the possible values V_{Imax}^C and V_{Imin}^C

The values of the vulnerability indexes may be presented, for each vulnerability class, as a set of five values as shown in Table 3.6. Because of the symmetry of the membership functions (plateau-shaped), only three out of these five values are independent.

The LM1 methodology defines, for the operational implementation of the methodology, mean semi-empirical vulnerability functions correlating the mean damage grade μ_D with the macroseismic intensity I and the vulnerability index V_I , as follows:

$$\mu_D = 2.5 \left[1 + \tanh \left(\frac{I + 6.25V_I - 13.1}{2.3} \right) \right] \quad \text{eq. 3.14}$$

It must be remembered that the belonging of a building to a certain vulnerability class (as observed in Table 3.3) is characterized by a prevailing vulnerability class. Inside a given class it is possible to find buildings with a better or worse seismic behavior, and it is also possible to find different building types behaving similarly (most likely, probable, and less probable ranges for the EMS-98 vulnerability classes). The LM1 methodology overcomes this aspect

again through the fuzzy set theory, by means of discriminating, through membership functions, the most likely class ($\chi=1$), the probable class ($\chi=0.6$), and the less probable class ($\chi=0.2$). It is possible then to define the membership function for each of the building types as a linear combination of the vulnerability class membership functions, considering each one with its own degree of belonging.

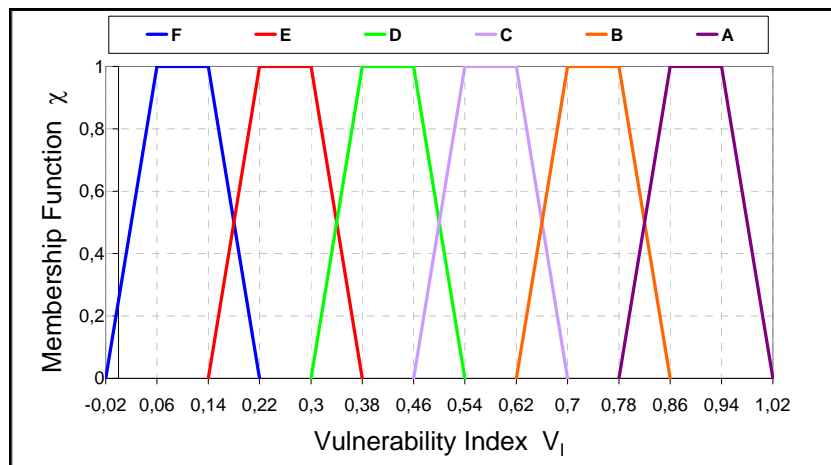

Figure 3.11: Membership functions of the vulnerability index [Multinovic and Trendafiloski, 2003].

Class	V_{Imin}^C	V_I^{C-}	V_I^{C*}	V_I^{C+}	V_{Imax}^C
A	0.78	0.86	0.9	0.94	1.02
B	0.62	0.7	0.74	0.78	0.86
C	0.46	0.54	0.58	0.62	0.7
D	0.3	0.38	0.42	0.46	0.54
E	0.14	0.22	0.26	0.3	0.38
F	0.02	0.06	0.1	0.14	0.22

Table 3.6: Vulnerability Index values for the vulnerability classes, after [Multinovic and Trendafiloski, 2003].

In this way, the *Building Typology Matrix* (BTM) for buildings in Europe consists in 23 building typologies, related to a set of representative values of vulnerability indexes, and taking into account the plausible, possible and less possible membership functions for each of the typologies with respect to the vulnerability classes in the EMS-98. In Table 3.7, some (15) of these typologies are shown with the respective attribution of vulnerability class to each of them, and the corresponding vulnerability index values. It may be verified how inside the EMS-98 vulnerability class A, two different typologies may be included: M1 (Rubble Stone) and M2 (Adobe, Earth Bricks), for which the LM1 methodology encounters differences between these two typologies via the vulnerability index, $V_I^* = 0.873$ for M1, and $V_I^* = 0.84$ for M2; thus, this last typology is slightly less vulnerable than the first one. Comparing these values with those in Table 3.6, both indexes are between the lower bound of uncertainty range and the lower bound of the possible values for the EMS-98 vulnerability class A.

Typologies		Building type	Vulnerability Classes						Vulnerability Classes				
			A	B	C	D	E	F	V_{Imin}	V_I^-	V_I^*	V_I^+	V_{Imax}
Masonry	M1	Rubble stone	■						0.62	0.81	0.873	0.98	1.02
	M2	Adobe (earth bricks)	■	■					0.62	0.687	0.84	0.98	1.02
	M3	Simple stone	■	■	■				0.46	0.65	0.74	0.83	1.02
	M4	Massive stone	■	■	■	■			0.3	0.49	0.616	0.793	0.86
	M5	Unreinforced M (old bricks)	■	■	■	■	■		0.46	0.65	0.74	0.83	1.02
	M6	Unreinforced M with r.c. floors	■	■	■	■	■	■	0.3	0.49	0.616	0.79	0.86
	M7	Reinforced or confined masonry	■	■	■	■	■	■	0.14	0.33	0.451	0.633	0.7
Reinforced Concrete	RC1	Frame in r.c. (without E.R.D.)	■	■	■	■	■		0.3	0.49	0.644	0.8	1.02
	RC2	Frame in r.c. (moderate E.R.D.)	■	■	■	■	■		0.14	0.33	0.484	0.64	0.86
	RC3	Frame in r.c. (high E.R.D.)	■	■	■	■	■		-0.02	0.17	0.324	0.48	0.7
	RC4	Shear walls (without E.R.D.)	■	■	■	■	■		0.3	0.367	0.544	0.67	0.86
	RC5	Shear walls (moderate E.R.D.)	■	■	■	■	■		0.14	0.21	0.384	0.51	0.7
	RC6	Shear walls (high E.R.D.)	■	■	■	■	■		-0.02	0.047	0.224	0.35	0.54
Steel	S	Steel structures	■	■	■	■	■		-0.02	0.17	0.324	0.48	0.7
Timber	W	Timber structures	■	■	■	■	■		0.14	0.207	0.447	0.64	0.86

Situations: ■ Most Likely; ■ Probable; ■ Less Probable (exceptional cases)

Table 3.7: Attribution of vulnerability classes and Vulnerability Index values for different building typologies, after [Giovinazzi and Lagomarsino, 2004].

As the vulnerability (in the EMS-98) depends also on other factors such as: quality of workmanship, state of preservation, regularity, ductility, position, strengthening, and earthquake resistant design level; the LM1 methodology suggests the following definition of the vulnerability index:

$$\bar{V}_I = V_I^* + \Delta V_R + \Delta V_m \quad \text{eq. 3.15}$$

Where, V_I^* is a *Typological Vulnerability Index*, ΔV_R is a *Regional Vulnerability Factor*, and ΔV_m is a *Behavior Modifier Factor*.

The typological vulnerability index is assigned by the similarity of the studied typology to a typology in the BTM; this index may be then adequated by means of:

- **The Regional Vulnerability Factor:** takes into account the particular quality of some building types at a regional level in the basis of expert judgment or taking into consideration the observed vulnerability.
- **The Behavior Modifier Factor:** this factor takes into account the different seismic deficiencies detected in a building identified as different partial scores where the weighed sum of the latter produces a global score, which represents a vulnerability index (such as the indexes obtained through the application of the ATC-21 or the Italian Vulnerability Index Method [GNDDT, 2001b]). The procedure proposed in the WP4-LM1 Methodology is conceptually similar, introducing the behavior modifiers as scores attributed through expert judgment. The behavior modifier Factors and the corresponding scores for Masonry and Reinforced Concrete buildings are shown in Table 3.8 and Table 3.9, respectively.

For the Behavior Modifier Factor, the score that modifies the characteristic vulnerability index V_I^* may be evaluated in two different ways, depending if the assessment is performed over a single building or over a set of buildings. The first case (single building) is solved by the simple sum of all the modifier scores, by the expression:

$$\Delta V_m = \sum V_m \quad \text{eq. 3.16}$$

The second case (several buildings), where a set of buildings is considered as belonging to a certain typology, the contributions of each single factor are added, in a weighed sum with the ratio of buildings within the set as follows:

$$\Delta V_m = \sum r_k V_{m,k} \quad \text{eq. 3.17}$$

where r_k is the ratio of buildings characterized by the modifying factor k with score $V_{m,k}$.

The WP4-LM1 Methodology is an innovative approach for seismic vulnerability assessment and damage forecast, which overcomes the differences between the typological and score assessment methods through an intermediate approach, graded to different levels in accordance with the quantity and quality of the available data and the size of the territory. The application procedure of such methodology is explained in Chapter 6 (Seismic Vulnerability) with an example: the vulnerability assessment of the buildings in Mérida.

<i>Vulnerability Factors</i>	<i>Parameters</i>	<i>V_m</i>
State of preservation	Good maintenance	-0,04
	Bad maintenance	0.04
Number of floors	Low (1 or 2)	-0.02
	Medium (3, 4 or 5)	0.02
	High (6 or more)	0.06
Structural system	Wall thickness	
	Distance between walls	
	Connection between walls (Tie-rods, angle bracket)	-0,04 ÷ +0,04
	Connection horizontal structures-walls	
Soft-story	Demolition/ Transparency	0.04
Plan Irregularity	...	0.04
Vertical Irregularity	...	0.02
Superimposed floors		0.04
Roof	Roof weight + Roof Thrust	
	Roof Connections	0.04
Retrofitting interventions		-0,08 ÷ +0,08
Aseismic Devices	Barbican, Foil arches, Buttresses	
	Middle	-0.04
	Corner	0.04
Aggregate building: position	Header	0.06
	Staggered floors	0.02
Aggregate building: elevation	Buildings of different height	-0,04 ÷ +0,04
Foundation	Different level foundation	0.04
Soil Morphology	Slope	0.02
	Cliff	0.04

Table 3.8: Scores for the vulnerability factors for Masonry Buildings [Giovinazzi and Lagomarsino, 2004].

<i>Vulnerability Factors</i>		<i>ERD level</i>		
		<i>Pre or Low Code</i>	<i>Medium Code</i>	<i>High Code</i>
Code Level		+0,16	0	-0,16
Bad Maintenance		0.04	0.02	0
Number of floors	Low (1 or 2)	-0,04	-0,04	-0,04
	Medium (3, 4 or 5)	0	0	0
	High (6 or more)	+0,08	+0,06	+0,04
Plan Irregularity	Shape	0.04	0.02	0
	Torsion	0.02	0.01	0
Vertical Irregularity		0.04	0.02	0
	Short-column	0.02	0.01	0
	Bow windows	0.04	0.02	0
Aggregate buildings (insufficient aseismic joint)		+0,04	0	0
Foundation	Beams	-0,04	0	0
	Connected Beams	0	0	0
	Isolated Footing	+0,04	0	0
Soil Morphology	Slope	0.02	0.02	0.02
	Cliff	0.04	0.04	0.04

Table 3.9: Scores for the vulnerability factors for RC Buildings [Giovinazzi and Lagomarsino, 2004].

3.3.2 Numerical models relationships

From the methodologies available and mentioned previously, the Risk-UE-WP4-LM2 methodology is presented, as it constitutes the superior companion of the WP4-LM1 methodology explained in the preceding section.

The LM2 method is based in two sets of building resistance/damage models, the Capacity and the Fragility models. The first, the capacity model, based in the pushover curves, is the overall force-displacement capacity of the structure which estimates the expected peak response of a building at a given demand, these capacity models represent the first response mode of the building assuming that it corresponds to the predominant mode of the building's vibration which controls primarily the damage generation and progress. The second, the fragility model, is a prediction model for the conditional probabilities of a building to undergo ($P_{sk}[D_s = ds|Y = y_k]$) or to exceed ($P_{sk}[D_s > ds|Y = y_k]$) specific damage states (ds) at specified ground motion levels (y_k). The input to estimate response is considered as the level and frequency content of the seismic excitation, in the form of a demand spectrum that is based either on the 5% damped building-site specific response spectrum (modified to account for structural behaviour out of the elastic domain), or on its alternate, an analogous inelastic response spectrum.

The process of damage assessment is then a model-based (analytical) one, where the models and its parameters can be estimated out of the seismic codes, in countries where they are strictly observed and complied, or by means of special modeling of as-built conditions based in the knowledge of the construction materials and construction practice (with the use of nonlinear analysis), which may serve both for the buildings not complying with the code or for pre-code buildings. The process of modeling requires three consecutive models of the building or group of buildings related to a ground movement parameter in the form of a demand spectrum, performed in a five-step procedure explained as follows:

1. Selection of the building model from the Risk-UE BTM, which represents adequately the building's or building's group characteristics: construction materials, structural system, height class, expected/identified design and performance level, etc.
2. For the selected model building, the capacity model and the conversion to capacity spectrum must be estimated.
3. Calculate/model the building's site-specific demand spectrum.
4. Calculate/model the expected building's performance (response) by intersecting the capacity spectrum with the demand spectrum and determining the intersection (performance) point, where the demand and capacity are equal. This estimation of the performance point identifies the demand at which the building or group of buildings should undergo identified damage states, as this point should be located in the nonlinear (inelastic) range of the capacity spectrum.
5. From a corresponding fragility model, estimate the conditional probabilities that for a determined performance point the building or building group will exhibit certain damage states.

The terms calculate and model correspond to damage assessment of a single building, or a building class, respectively. The three models involved in the procedure can be developed as follows:

Capacity Model: the first model to develop is the capacity model, which relates the lateral load resistance (base shear V) and the characteristic lateral displacement of the building (peak

building roof displacement, Δ_R). This capacity model is an idealized capacity curve defined by two characteristic control points (see Figure 3.12): the Yield Capacity (YC) and the Ultimate Capacity (UC). These control points are defined as:

Yield Capacity (YC): is the lateral load resistance strength of the building before the structural system has developed a nonlinear response (eq. 3.18 and Figure 3.12). When defining redundancy factors in the design, conservatism in code requirements and true strength of materials (rather than nominal as defined by standards for code designed and constructed buildings) have to be considered.

Ultimate Capacity (UC): is the maximum strength of the building when the global structural system has reached a fully plastic state, where the buildings surpassing this point of capacity are considered capable of deforming without loss of stability but the structural system does not provide additional resistance to lateral seismic forces (eq. 3.19 and Figure 3.12).

$$YC(V_y, \Delta_y): \quad V_y = \gamma C_s; \quad \Delta_y = \left(\frac{V_y}{4\tau^2} \right) T^2 \quad \text{eq. 3.18}$$

$$UC(V_u, \Delta_u): \quad V_u = \lambda V_y = \lambda \gamma C_s; \quad \Delta_u = \lambda \mu \Delta_y = \lambda \mu \gamma C_s \left(\frac{T^2}{4\tau^2} \right) \quad \text{eq. 3.19}$$

where:

- C_s is the design strength coefficient (fraction of the building's weight)
- T is the true elastic fundamental-mode period of the building (in seconds)
- γ is the overstrength factor relating design strength to true yield strength
- λ is the overstrength factor relating ultimate strength to yield strength
- μ is the ductility factor relating the ultimate displacement (Δ_u) to λ times the yield (Δ_y) displacement (i.e. assumed point of significant yield of the structure).

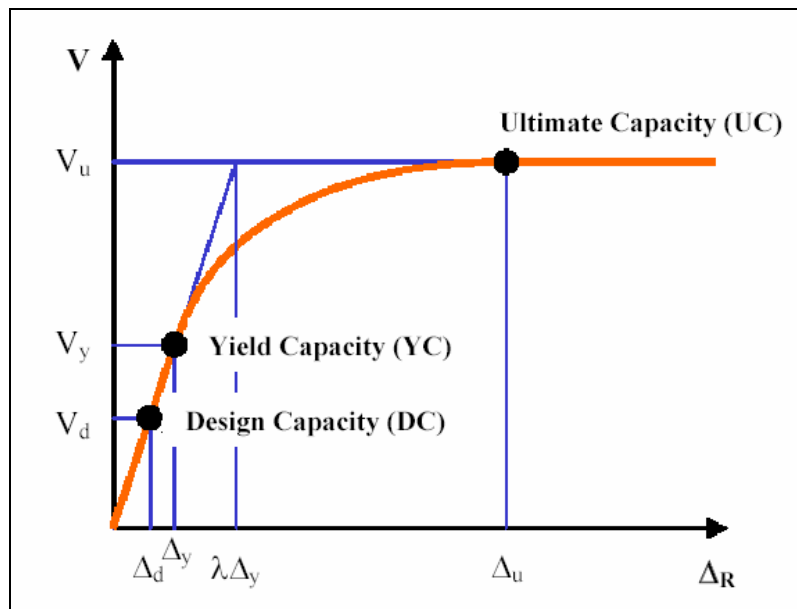

Figure 3.12: Building capacity model [Multinovic and Trendafiloski, 2003].

For the capacity curves, the building capacity is considered to be linear with stiffness, up to the Yield point based on an estimate of the true period of the building; from this point to the Ultimate point, the capacity curve transitions in slope from an essentially elastic state to a

fully plastic state, and beyond this ultimate point the capacity curve is assumed to remain plastic. The design strength coefficient C_s is based on the prescribed lateral force requirements in countries where the code is strictly implemented and it is assured by a rigorous legal system, otherwise, this coefficient is controlled by the local construction tradition and practice as well as the quality of locally available construction materials. The building capacity curves, and the corresponding parameters can be developed either analytically, through nonlinear (Response History Analysis, RHA) or nonlinear static analysis of formulated analytical prototypes (NSP) of model buildings; or on the basis of expert's estimates on the parameters controlling the building performance. This last approach (expert's estimates) is based on parameter's estimates prescribed by seismic design codes and construction material standards, and is known as the Code Based Approach (CBA) [Multinovic and Trendafiloski, 2003].

Capacity Spectrum: as the building capacity must be compared to the demand spectrum, the capacity curve is to be converted into a capacity spectrum in order to estimate the performance point of the building or group of buildings. The capacity spectrum is presented in the AD (spectral acceleration/spectral displacement) format for which the base shear (V) is converted into spectral acceleration (S_a) and the roof displacement (Δ_R) into spectral displacement (S_d). This conversion of the capacity model (V, Δ_R) to the capacity spectrum (S_a, S_d) requires the knowledge of the dynamic characteristics of the structure in terms of its period (T), mode shape (Φ_i) and lumped floor mass (m_i) (equations 3.22, 3.23 and 3.24). For this purpose a SDOF (Single Degree Of Freedom) system is used to represent the translational vibration mode of the structure. As in the capacity curve, two control points define the capacity spectrum, the Yield Capacity (YC) and the Ultimate Capacity (UC) (see Figure 3.13). The expressions for these control points are:

$$YC(A_y, D_y): \quad A_y = S_{ay} = \frac{C_s \gamma}{\alpha_1}; \quad D_y = S_{dy} = \left(\frac{A_y}{4\tau^2} \right) T^2 \quad \text{eq. 3.20}$$

$$UC(A_u, D_u): \quad A_u = S_{au} = \lambda A_y = \frac{\lambda \gamma C_s}{\alpha_1}; \quad D_u = \lambda \mu D_y = \lambda \mu \frac{C_s \gamma}{\alpha_1} \left(\frac{T^2}{4\tau^2} \right) \quad \text{eq. 3.21}$$

The coefficient α_1 is an effective mass coefficient (or fraction of the building's weight effective in the push-over mode), defined with the building's dynamic characteristics as follows:

$$\alpha_1 = \frac{[\sum m_i \Phi_i]^2}{\sum m_i \sum m_i \Phi_i^2} \quad \text{eq. 3.22}$$

where m_i is the i -th story masses, and Φ_i is the i -th story modal shape coefficient.

Each mode of a Multiple Degree Of Freedom (MDOF) system can be represented by an equivalent SDOF system with an effective mass (M_{eff}) with the form:

$$M_{eff} = \alpha_1 M \quad \text{eq. 3.23}$$

where M is the total mass of the structure.

Considering that the first mode dominantly controls the response of the multistory buildings, and that when the equivalent mass of SDOF moves for a distance S_d , the roof of the multi-storey building moves for distance Δ_R , the ratio of $\Delta_R / S_d = PF_{R1}$ is defined as the modal participation for the first (fundamental) mode at the roof level of the MDOF system, with the form:

$$PF_{R1} = \left(\frac{\sum m\Phi_1}{\sum m\Phi_1^2} \right) \Phi_{R1} \quad \text{eq. 3.24}$$

where Φ_{R1} is the first mode shape at the roof level of the MDOF system.

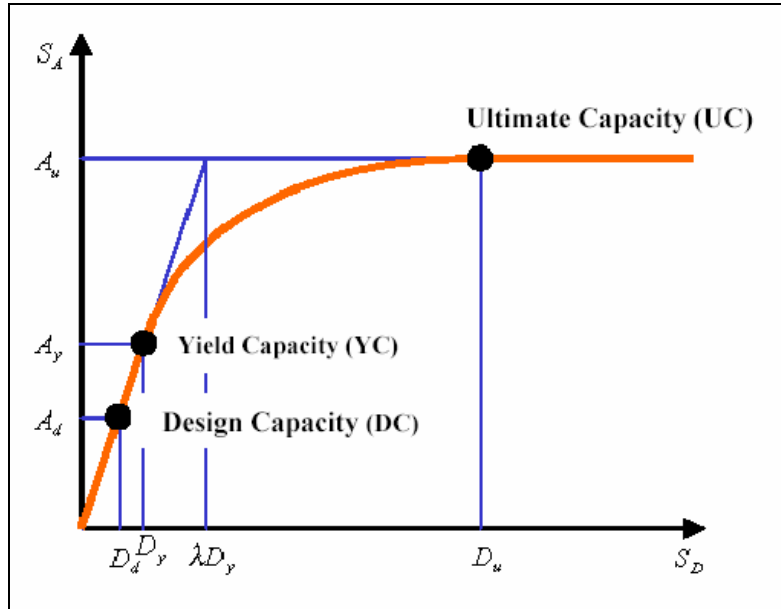

Figure 3.13: Building capacity model [Multinovic and Trendafiloski, 2003].

The quantitative definition of the capacity model and the related AD spectrum, requires five parameters to be known or estimated:

- Design Strength, C_S
- Overstrength factors, γ and λ
- Ultimate point ductility, μ
- Typical elastic period of the structure, T

For the CBA (Code Based Approach) the capacity model parameters may be estimated from the prescribed parameters in the seismic codes and by expert's judgment, otherwise, the parameters estimation is performed analytically for model buildings in the BTM.

The fundamental period for the buildings (T) can be estimated using empirically developed expressions that have been modified to reflect the true structural properties. Several estimation expressions are available depending on the country and the building typology, some of the countries and expressions are shown in Table 3.10.

Country	Building type	FUNDAMENTAL PERIOD, T (S)
Greece		$T = 0.09 \frac{H}{\sqrt{L}} \sqrt{\frac{H}{H + \rho L}}$
		$\rho = \text{ratio of the area of RC shear walls to the total area of the shear walls and RC columns, in a typical story of the building}$
Italy		$T_0 = \frac{0.1H}{\sqrt{L}}$
	RC Buildings with structural walls	$T = 0.06 \frac{H}{\sqrt{L}} \sqrt{\frac{H}{2L + H}} \geq 0.50$
Spain	RC buildings	$T_0 = 0.09 \frac{H}{\sqrt{L}} \geq 0.50$
	Steel buildings	$T = 0.10 \frac{H}{\sqrt{L}} \geq 0.50$
		<i>For RC buildings with structural walls or with steel bracing, the values for the fundamental period T should be multiplied by factor f given by:</i>
		$f = 0.85 \sqrt{1/(1 + L/H)}$
	Buildings with masonry, or cast-in-place concrete structural walls	$T = 0.06 \frac{H}{\sqrt{L}} \sqrt{\frac{H}{2L + H}}$
	Buildings with RC shear walls or with steel or concrete bracing	$T = 0.08 \frac{H}{\sqrt{L}} \sqrt{\frac{H}{2L + H}}$
France	RC buildings with moment resisting frames	$T = 0.09 \frac{H}{\sqrt{L}}$
	Steel buildings with moment resisting frames	$T = 0.10 \frac{H}{\sqrt{L}}$
		$H = \text{Height of the building}$
		$L = \text{dimension in plan in direction of the seismic force}$
		$n = \text{Number of floor levels (number of stories)}$

Table 3.10: Fundamental periods of typical RC systems, after [Multinovic and Trendafiloski, 2003].

The capacity spectrum is represented either way in a bilinear form where the capacity model parameters (A_y , D_y and A_u , D_u) are the controlling points of the model. In Figure 3.14, the capacity spectra for the building typology: High-Rise Pre-Code Reinforced Concrete Moment Frames building (RC1H PC), is presented both for an analytical approach performed by UNIGE (Università degli Studi di Genova), and a CBA performed by UTCB (Technical University of Civil Engineering of Bucharest), it may be verified how the control points are different for each of the approaches, and it may be considered that the estimations from UTCB render a more ductile and stronger construction than that of the UNIGE.

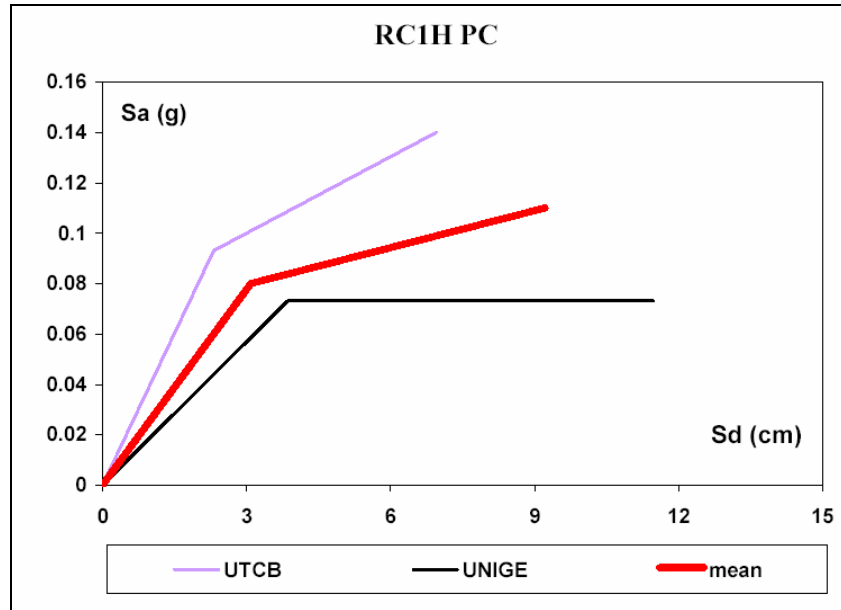

Figure 3.14: RC1HPC building typology capacity spectra [Multinovic and Trendafiloski, 2003].

Fragility Model: a building fragility model consists of a suite of fragility curves defining the conditional probability of being in ($P[D_s = ds]$) or exceeding ($P[D_s > ds]$) a certain damage state (ds). The LM2 methodology defines four damage states denoted as: minor (1), moderate (2), severe (3), and very heavy damage and collapse (5). The fragility curves for a fragility model have the form:

$$P[ds|S_d] = \Phi \left[\frac{1}{\beta_{ds}} \ln \left(\frac{S_d}{\bar{S}_{d,ds}} \right) \right] \quad \text{eq. 3.25}$$

where:

S_d is the spectral displacement or the seismic hazard parameter

$\bar{S}_{s,ds}$ is the median value of the spectral displacement at which the building reaches a certain threshold of the damage state ds

β_{ds} is the standard deviation of the natural logarithm of spectral displacement of damage state ds

Φ is the standard normal cumulative distribution function

The fragility curves are defined by means of two fragility model parameters, the median value of the spectral displacement $\bar{S}_{s,ds}$ and the standard deviation β_{ds} , where the median value represents the point at which the probability of being in or exceeding a damage state is equal to 50%, and the standard deviation gives an idea of the scattering for the distribution.

Several methods are used to estimate the median values of structural fragility, one example is the FEMA/NIBS approach, which considers that these median values are based on building drift ratios describing the damage thresholds for the buildings, these damage thresholds of building drift ratios are converted in spectral displacement by using the expression:

$$\bar{S}_{d,ds} = \delta_{R,Sds} \alpha_2 h \quad \text{eq. 3.26}$$

where,

$\delta_{R,Sds}$ is the drift ratio at the threshold damage state ds

α_2 is the fraction of the building (roof) height at the location of the pushover model displacement

h is the typical height of the model building type of interest

The process of modeling has the final objective to relate the modeled building drift ratios with the damage states. In Table 3.11, the drift ratios and the corresponding damage states are shown for Masonry and Reinforced Concrete buildings, developed by different RISK-UE partners, where AUTH is the Aristotle University of Thessaloniki, UNIGE is the Università degli Studi di Genova, and CIMNE is the International Centre for Numerical Methods in Engineering of Barcelona.

Damage Grade	Definition	Displacement Limits (AUTH)	Spectral Displacement Limits (UNIGE, CIMNE)
0	No damage	$\Delta < 0.7\Delta_y$	$\mathbf{D} < 0.7 \text{ Dy}$
1	Slight damage	$0.7\Delta_y < \Delta < 0.7\Delta_y + 0.05*\Delta_{uy}$	$0.7\text{Dy} \leq \mathbf{D} < 1.0 \text{ Dy}$
2	Moderate damage	$0.7\Delta_y + 0.05*\Delta_{uy} < \Delta < 0.7\Delta_y + 0.20*\Delta_{uy}$	$1.0 \text{ Dy} \leq \mathbf{D} < \text{Dy} + \text{Duy}$
3	Extensive damage	$0.7\Delta_y + 0.20*\Delta_{uy} < \Delta < 0.7\Delta_y + 0.50*\Delta_{uy}$	$\text{Dy} + \text{Duy} \leq \mathbf{D} < \text{Du}$
4	Very heavy damage	$0.7\Delta_y + 0.50*\Delta_{uy} < \Delta < 0.7\Delta_y + 1.00*\Delta_{uy}$	$\text{Du} \leq \mathbf{D}$
		$\Delta_{uy} = 0.9\Delta_u - 0.7\Delta_y$	$\text{Duy} = 0.25*(\text{Du} - \text{Dy})$

Table 3.11: Building Drift Ratios at the Threshold of Damage States, after [Multinovic and Trendafiloski, 2003].

In Figure 3.15, a set of fragility curves are shown, for the building typology: Medium Height Reinforced Concrete Moment Frames (RC1M), estimated by the Institute of Earthquake Engineering and Engineering Seismology (IZIIS) by means of a Code Based Approach (CBA). These probabilities in the fragility curves may also be expressed as a Damage Probability Matrix, if for each of the spectral displacements, each of the damage states probabilities are expressed as the difference with the unity of the conditional exceeding probability in the fragility curves.

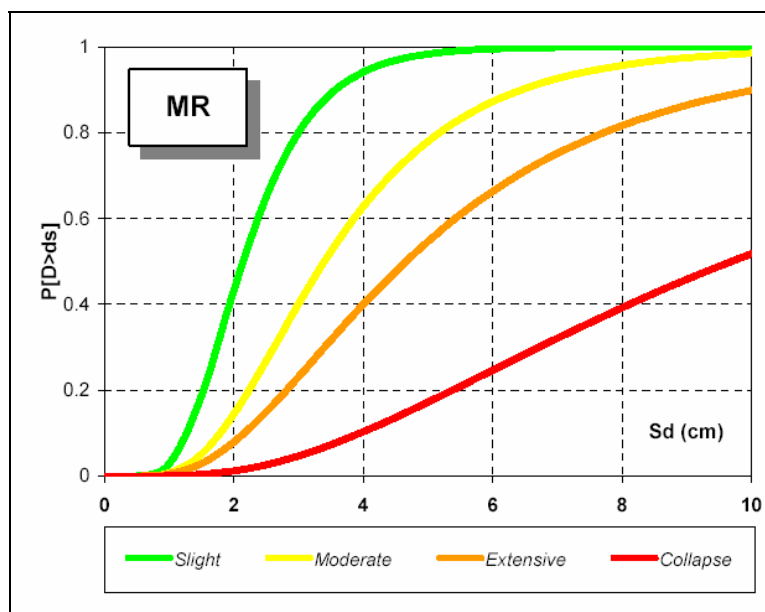

Figure 3.15: Example of fragility model (RC1/CBA Medium Height) [Multinovic and Trendafiloski, 2003].

The WP4-LM2 methodology is a powerful tool for seismic vulnerability assessment and damage forecast, and accounts for fragility models for the building typologies in the RISK-UE BTM. However available in Europe for the cities belonging to the Project, the

applicability of this methodology in another place in the world requires to estimate the capacity models (Capacity curve and spectra), the demand spectra for the site, and the fragility models for the building stock of interest; in countries where the information available about the buildings is scarce or inexistent, the application of such methodology requires to use teams of experts to build-up the useful data about the buildings and forwardly develop the different models required.

3.4 Comparative analysis of vulnerability assessment approaches

In order to establish comparisons between the different approaches presented, their essential features are highlighted. These features correspond to the identification and description of the buildings, the vulnerability descriptor, the vulnerability-damage relationships, and the data quantity and quality on the buildings.

Identification and description of the buildings: considers how the approach identifies and describes the building or building group of interest, where the information must come from a categorization previously established. In this feature, both the LM1 and LM2 approaches identify and describe the buildings through the use of a common building typology matrix, on the other hand, the IVIM identifies the buildings within a broader building type, for example, between Reinforced Concrete (RC) buildings and Masonry buildings, where subtypologies (within each of these) are differentiated by the vulnerability index.

Vulnerability descriptor: corresponds to the seismic vulnerability classification of the building or building group, and the expression used for this purpose. In the case of the IVIM and the LM1 approaches, the vulnerability descriptor is an index, while for the LM2 is a set of fragility curves. The vulnerability index is a more direct and easily understanding descriptor based in a single number in a scale (0 to 100, 0 to 1, etc.), on the other hand, the fragility curves are a set of arranged data that describe the probability to be in or to exceed the four damage states for a range of spectral displacements, the comparison of two typologies in this case, requires the comparison of the two sets of curves.

Vulnerability-damage relationships: the objective of vulnerability description is to perform an estimation of the probable damage to be generated in a described building or building group due to the occurrence of a determined seismic event, relating the vulnerability descriptor with the damage states. The LM1 and LM2 approaches can express this relationship, for each typology, in the form of a DPM for each intensity (in LM1) or spectral displacement (in LM2), and/or a set of fragility curves (for each intensity in LM1, and for a range of spectral displacements in LM2). There are substantial differences between the two approaches related on how the vulnerability functions are obtained. For the LM1, the vulnerability index of the typology and the intensity are enough to estimate the probabilities for each damage state, on the other hand, for the LM2 approach, numerical models of the typology have to be built-up: the capacity curve, the capacity spectrum, the demand spectrum and the fragility curves. The IVIM approach expresses the relationship based in a curve (fitted from observed damage, or modeling of damage) for each building type and intensity, where the vulnerability index is related to a damage index, however this approach seems to be the simplest one of the three to estimate damage, the function may not be applied directly in other regions of the world. The same feature is found in the LM2 approach, as the vulnerability functions are obtained from analytical models for a specific building typology. In contrast, the LM1 approach accounts for procedures to estimate the vulnerability index of a building typology not present in the BTM.

Data quality and quantity on the buildings: this feature considers the required information about the buildings to perform adequately the vulnerability assessment. Depending on the

approach used in the development of the vulnerability-damage relationships, the level and nature of the information required varies significantly.

In the case of the LM1 approach the level of information required is the lowest of all three, this due to the fact that the identification of the building is performed through a BTM associated to vulnerability indexes, this identification might be direct, in which case the indexes are associated univocally and used for damage forecast; or indirect, in case that the building is not identified completely from the BTM. For this situation, the LM1 methodology recommends defining more general categories on the basis of experience and the knowledge of the construction tradition, and adequating a preliminary set of values for the vulnerability indexes using the *behavior modifier factors* (which are estimated through visual inspection), the *regional modifier factors* (subjective factor based on expert judgment) and an *uncertainty range* (depending on the type of available data for assessment). This approach allows estimating the vulnerability indexes easily and without much additional information about the buildings other than the typological identification.

The IVIM assessment is performed by visual inspection of the buildings, pursuing the qualification of the eleven parameters by the use of the second level assessment form, where only parameter 3 (Conventional Resistance) requires to know a specific parameter of the structure (shear resistance of the concrete), thus, the assessment is mostly qualitative. As the required information is the result of an individual survey of the building, the time expenditure in qualification of the building is larger than the required for the LM1 approach.

For the LM2 approach, the knowledge of the as-built conditions and the particular construction practice and construction materials quality of the buildings are essential to elaborate the respective numerical models (capacity curves, capacity spectrum, and fragility curves), this knowledge may be the result of the analysis of the building's documentation in a cadastral database, where the age of the building is used to identify the seismic code in effect at the design and construction process of the building, under conditions in which the strict implementation of the code is assured by a rigorous legal system. On the other hand, when the information does not have these characteristics, the analysis has to be performed based on the knowledge of the construction tradition and practice and on the quality of the locally available construction materials. The effort in this approach is centered on the development of the numerical models for the buildings.

Lantada et. al., (2004), perform assessment and risk scenarios for the city of Barcelona, Spain, using both the WP4-LM1 and WP4-LM2 methodologies, where the differences are not only in the detail level required for the buildings description, but also in the seismic input, as the LM1 method requires only EMS-98 intensity degrees and LM2 requires response spectra for the study zone; although the differences, the conclusions are that both methodologies render excellent results, showing an excellent correlation with the main features of the built environment of Barcelona.

3.5 Summary

The choice of a certain methodology for vulnerability assessment must consider the purpose of the assessment, the size of the urban center, the building typologies within it, and the level of information available about the buildings. Also, an important issue such as the expenditure of computational effort in developing vulnerability-damage relationships, must be considered. This issue is explained by Lang 2002, in a discussion on the choice of vulnerability assessment methods, which outlines the different approaches in increasing order of computational effort, starting with the observed vulnerability and expert opinions approaches,

followed by the simplified numerical models and score assignment, and finally with the detailed numerical models approaches which are considered as the most expensive in computational effort (see Table 3.12).

Expenditure	Increasing Computational Effort →				
	Building Stock			Individual Building	
Application					
Approaches	Observed Vulnerability	Expert Opinions	Simplified Numerical Models	Score Assignment	Detailed Numerical Models

Table 3.12: Approaches for seismic vulnerability assessment of buildings, after [Lang, 2002].

The applicability of the different approaches to seismic vulnerability assessment, rely in the scope of the assessment and the level of the detail required from the interest building stock, also, it is important to denote that although a level of detail might be required, the conditions of knowledge about the as-built conditions in the interest zone are essential to fulfill these requirements.