

ADVERTIMENT. La consulta d'aquesta tesi queda condicionada a l'acceptació de les següents condicions d'ús: La difusió d'aquesta tesi per mitjà del servei TDX (www.tesisenxarxa.net) ha estat autoritzada pels titulars dels drets de propietat intel·lectual únicament per a usos privats emmarcats en activitats d'investigació i docència. No s'autoritza la seva reproducció amb finalitats de lucre ni la seva difusió i posada a disposició des d'un lloc aliè al servei TDX. No s'autoritza la presentació del seu contingut en una finestra o marc aliè a TDX (framing). Aquesta reserva de drets afecta tant al resum de presentació de la tesi com als seus continguts. En la utilització o cita de parts de la tesi és obligat indicar el nom de la persona autora.

ADVERTENCIA. La consulta de esta tesis queda condicionada a la aceptación de las siguientes condiciones de uso: La difusión de esta tesis por medio del servicio TDR (www.tesisenred.net) ha sido autorizada por los titulares de los derechos de propiedad intelectual únicamente para usos privados enmarcados en actividades de investigación y docencia. No se autoriza su reproducción con finalidades de lucro ni su difusión y puesta a disposición desde un sitio ajeno al servicio TDR. No se autoriza la presentación de su contenido en una ventana o marco ajeno a TDR (framing). Esta reserva de derechos afecta tanto al resumen de presentación de la tesis como a sus contenidos. En la utilización o cita de partes de la tesis es obligado indicar el nombre de la persona autora.

WARNING. On having consulted this thesis you're accepting the following use conditions: Spreading this thesis by the TDX (www.tesisenxarxa.net) service has been authorized by the titular of the intellectual property rights only for private uses placed in investigation and teaching activities. Reproduction with lucrative aims is not authorized neither its spreading and availability from a site foreign to the TDX service. Introducing its content in a window or frame foreign to the TDX service is not authorized (framing). This rights affect to the presentation summary of the thesis as well as to its contents. In the using or citation of parts of the thesis it's obliged to indicate the name of the author

Polytechnic University of Catalonia
Ph.D. Program: Architectural Design
Department: Architectural Design, ETSAB

Ph.D. Thesis:

New Principles and Variations in the Architecture of Alvar Aalto

Competition entry for the hospital complex of Zagreb, Yugoslavia (1930-1931)



PHD Candidate : VLADANKA ZMIJANOVIC
Director: LUIS ANGEL DOMINGUEZ MORENO

Thesis presented to obtain the qualification of Doctor from the Polytechnic University of Catalonia

Barcelona, 2016

INDEX

INTRODUCTION	3
PREVIOUS NOTES	6
METHODOLOGY	12
STRUCTURE AND CONTENT	13
1. CHAPTER I : AALTO'S CONTEXT	16
1.1. AALTO'S DRAWN THOUGHTS	17
1.2. AALTO'S WRITTEN THOUGHTS	19
1.3. AALTO'S GUIDANCE PATHS IN THE YEARS 1929-1930	22
1.4. AALTO'S HEALTH BUILDINGS	26
2. CHAPTER II : COMPETITION CONTEXT	32
2.1. "ACCEPTERA" – ZAGREB	33
2.2. CIAM GROUP OF YUGOSLAVIA. REPRESENTATIVE ERNEST WEISSMANN	35
2.3. GENERAL INFORMATION/COMPETITION PROGRAM	37
3. CHAPTER III AALTO'S COMPETITION ENTRY.....	42
3.1. AALTO AND THE SITE AS "ACROPOLIS"	43
3.2. "NATURAL" URBAN PLANNING- SPATIAL THEORY : "EDGE EFFECT"	46
3.3. URBAN PLANNING ON THE SITE	50
3.3.1. NATURAL CONFIGURATION.....	51
3.3.2. ZONING.....	53
3.4. RECEPTION BUILDING OF THE COMPLEX.....	62
3.5. THE NEUROPSYCHIATRIC CLINIC.....	64
3.6. I ZONE CLINICS AND THE SCHOOL OF MEDICINE	66
3.6.1. PR1 "HEAD AND BODY" IN THE BIODYNAMIC MOVEMENT	82
3.6.2. PR2 "AMPHITHEATRE"	82
3.6.3. PR3 "RECTANGULAR AUDITORIUM-TRANSITIONAL FORM"	110
3.6.4. PR4 "MULTIPLICATION OF THE SAME SPECIES"	120
3.6.5. PR5 "DAYLIGHT TECHNIQUES"	132
3.7. II ZONE: GENERAL HOSPITAL WITH 7 CLINICS	142
3.7.1. PR6 "BACKBONE"	142
3.8.1. III ZONE: CENTER OF RADIOLOGY AND PHYSIOTHERAPY.....	156
3.8.2. IV ZONE: SERVICE CENTER OF THE COMPLEX	162
3.8.3. PR7 STEPPED IN THE VERTICAL PLANE CORRELATED WITH THE GROUND.....	172
3.9. V ZONE: RESIDENTIAL AND ADMINISTRATIVE ZONE	180
3.9.1. PR8 STEPPED IN THE HORIZONTAL PLANE	188
4. SANATORIUM BUILDING AND INTERACTION WITH THE PAIMIO SANATORIUM	202
5. CONCLUSIONS	208
6. BIBLIOGRPAHY	222
7. ANNEX	228

Abbreviations used during the study:

HCZ – Competition for the Hospital Complex in Zagreb, 1930-31, complete title of the hospital complex with two parts: "Foundation Hospital and Clinics of the School of Medicine of Zagreb, 1930-1931"

CIAM – Congrès Internationaux d'Architecture Modern

Abbreviations of the sources of the Archive of the Documentation consulted:

AAA- Archive of Alvar Aalto (Alvar Aalto Foundation and Museum of A.Aalto)

"Zagrabiensia" - Collection "Zagrabiensia" of the City Library of Zagreb

AKNOWLEDGMENTS

I would like to extend thanks to the many people, in many countries, who so generously contributed to the work presented in this thesis.

My deepest gratitude is to my advisor Professor Dr. Luis Angel Dominguez and to Professor Dr. Josep Muntañola, I've learned a lot from him.

The thesis would not have been possible without the work and kindness of the staff of various institutions and archives in Finland. Special mention to Alvar Aalto Foundation, both in Helsinki and Jyväskylä, Mia Hipeli, Katarina Pakoma, Timo Riekko and many others, Museum of Architecture from Helsinki, and also to Petra Leikas and Karoliina Vitikainen.

Special mention to the Institute of Art History of Zagreb, in particular to Tamara Bjazic Klarin and Irena Simic. Similar, gratitude to Dubravka Petek from the City Library of Zagreb (Collection "Zagrabiensia").

I would like to express my heart-felt gratitude to my father, mother and my brother for all their support; to my friends, where I have to give a special mention for the support given by Emilie.

“Architecture is a conception of the mind. It must be conceived in the head with our eyes closed. Only in this way we can display our project. The paper is only the means to record and transmit the idea to the client or the contractor”

“If I were to teach architecture”, 1934, Le Corbusier

“Basically, architecture is not only a certain quantity of built and finished results but a laminate development process to a higher level, which together with the inner interaction, continually creates new solutions, new forms, new materials for the construction and constant changes of the constructive ideas.

*The groups of buildings should be able to be realized freely, out of the given requirements, and all the regulations that point to a superficial or formal resemblance should be marginalized. Our society would gradually develop free groups of the buildings that in their interrelation have been willing to satisfy both aesthetic and practical considerations”.*¹

¹ Aalto Alvar. *The Humanization of Architecture*, Nordic Building Conference in Oslo, 1938



Aalto described the birth of the architectonic idea by using the metaphor of the trout and the stream:

This thesis treats the ideas and **new principles**, as **"leitmotifs"** of the **Alvar Aalto's "architectural language"** as a metaphoric comparison of the **birth of the salmon** and trout: **"born hundreds of miles away from their home grounds"**.

In this phrase, we could recognize the meaning of the new ideas as some of the new principles important of Aalto's work, born far away from his home ground, in the competition entry for the Hospital complex of Zagreb (1930/31):

(...) Architecture and its details are in some way all parts of biology. Perhaps they are, for instance, like some big salmon or trout. They are not born fully grown; they are not even born in the sea or water where they normally live. They are born hundreds of miles away from their home grounds, where the rivers narrow to tiny streams, in clear rivulets between the fells, in the first drops of water from the melting ice, as remote from their normal life as human emotion and instinct are from our everyday work. Just as it takes time for a speck of fish spawn to mature into a fully-grown fish, so we need time for everything that develops and crystallizes in our world of ideas. Architecture demands even more of this time than other creative work²

² Aalto Alvar, *The trout and the stream*, Domus, 1947

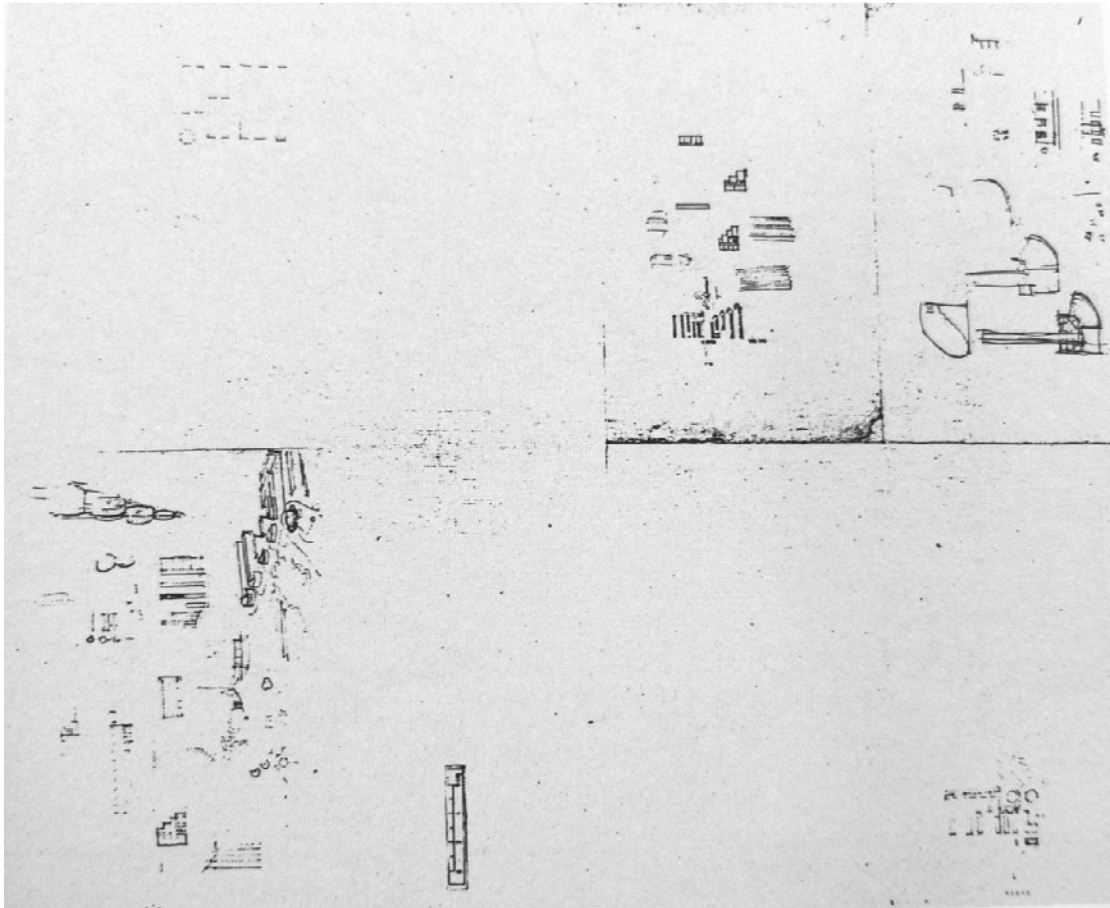

P1

P2



FIG P1.- Alvar Aalto's sketch, the other side of the paper of the Map of Zagreb delivered with all documents and plans of the competition on the large format, source: 50/608b, AAA (the page of the sketches as synthesis of the main ideas of the own Aalto's architectural language from this competition, which he used later during his career)

FIG P2. - Map of Zagreb delivered with the material of the competition on the large format), source: 50/608A, AAA

PREVIOUS NOTES

Christian Norberg-Schulz based his theory on the phenomenological aspects of the place and explain the primary role of the architecture: "to understand the vocation of the place".³ This theory it can confirm "therapeutic architecture" of Alvar Aalto (1898-1976), analyzed in the case study of this thesis: *"New principles and variations in the Architecture of Alvar Aalto: Competition entry for the hospital complex of Zagreb, Yugoslavia, 1930/31"*.

Aalto these years, 1929-30, after his first performed Functionalism projects, developed on some competition entries one synthesis of the many ideas of his "own architectural language", created together with *genius loci* and the identity of the place, where in the future these ideas will be connected with his interactive memory, based on associations in parallel times, the present space (context) and his past experiences as the space-time determinant. Aalto creates his architectural language on this project as a reinterpretation of the elements of the place together with the associations from ancient cultures of Italy, Greece, Egypt and Mesopotamia and at the same time linked with the *genius loci* of the place on the Salata hill and the elements of the existing, old built hospital complex respecting all requirements of the program.

This study investigates the primary origins of these ideas, as the main constitutive elements of Aalto's architectural language where this proposal for the "hospital city" on the terraced hill of HCZ project can be observed as a series of images from the local environment, originating from his experiences and admiration of ancient cultures. This design process can be viewed as the product of interactivity of memory based on associations that give meaning and form to his future architecture. In the ancient cultures, architecture was based on the human relationship with nature (sense of place) and with the very simple elementary forms, it achieved monumental and spiritual features. By analyzing this project in a metaphorical way, we could recognize some pure "sacred" forms as the Acropolis, classic Amphitheatre, Ziggurat and Hatshepsut palace on the site of the Aalto's HCZ competition entry.

³ Schulz Norberg Christian, "Phenomenon of Place" Architectural Quarterly 8, no 4, (1976), 3-10, Reprinted in Nesbitt, Theorizing a New Agenda of Architecture, 414. *Intentions in Architecture*, Cambridge: Massachusetts: MIT Press, 1965.

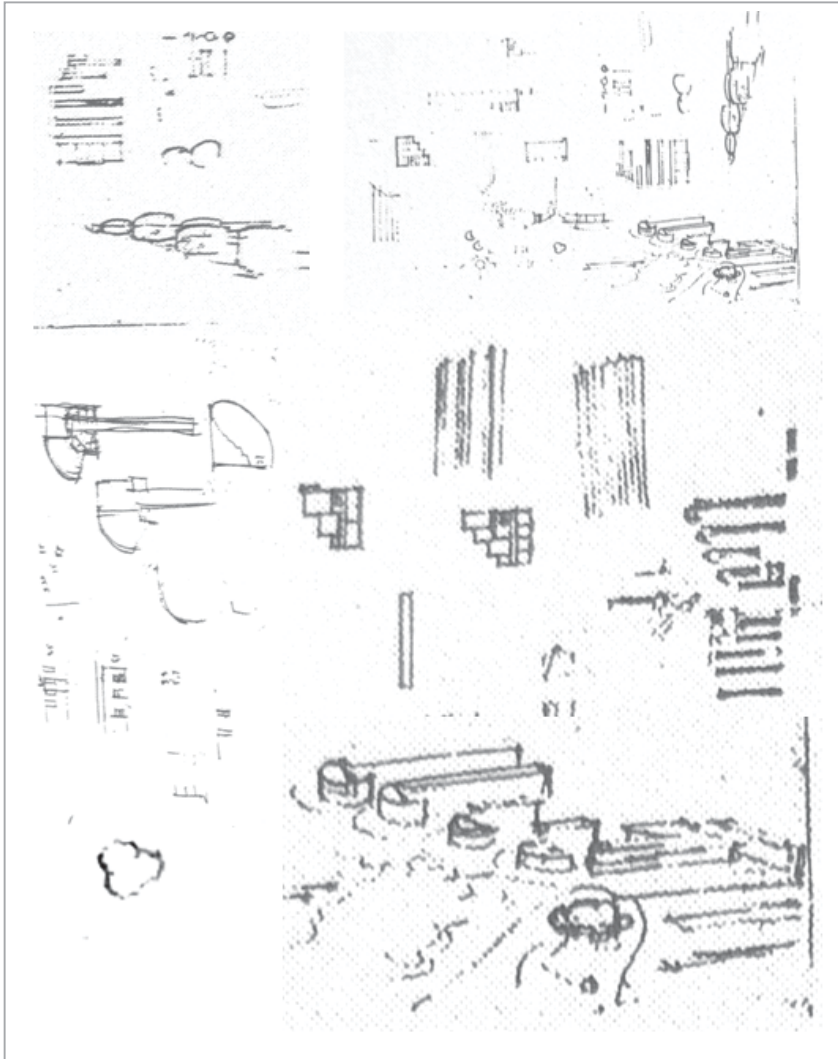

FIG P3.- Collage of the Aalto's sketches, made by author of the thesis, from the paper, 50/608b (AAA(on the reverse side of the paper of the Map of Zagreb delivered with all documents of the competition on the large format, source of the sketches from 50/608b, AAA, collage of the segments of the Aalto's sketches

SYNTHESIS OF THE NEW IDEAS AND PRINCIPLES FROM THE PROJECT ON THE ONE PAPER P3

Aalto, after his first travels to Italy 1924, said that he always kept in mind a trip to Italy⁴, and it's very evident and dominant that influence, like a "obsession"⁵ with the ancient cultures during his career. All Aalto's experiences created the base of the interactive memory which contains associations directly connected with conscious, subconscious and unconscious in the mind, where all together form something as "*Methexis*", the power which enables something to happen.

One could understand the meaning of the subconscious and unconscious in the creative process of Aalto by reading his article: "*The trout and the mountain stream*",⁶ where he describes the close collaboration of the conscious and unconscious in his design process. He explains that with the pressure of the roles and requirements of any program of the project, he always returns to the subconscious and unconscious to finally find a solution on the conscious level.

The first step in this process, it is possible to understand by analyzing his first sketches of the hospital complex of Zagreb competition project, based on the associations and inspirations of the images "extracted" directly from the *genius loci* and existing built and natural context on the hill "Siroki Brijeg" ("*Wide Hill*"). These images will be the main sources of the inspiration in realizing the subconscious "travel" as the act in the process of memory based on the association of the images from the present place and his previous experiences always presents in mind, as the way to find the solution that give "harmony to all elements of the process".⁷ His first connections with the associations from the previous experiences show us the roots of the project where he described the site of the competition of Zagreb as the "*Acropolis*" on the hill, with terraced hillsides and the new complex as the "*crown of the city*".⁸

⁴ Schildt G, "*Alvar Aalto in his own words*"; New York: Rizzoli, 1997

⁵ Aalto called his admiration for the Ancient cities on the mountains of the Toscana's landscapes, his "religion" and "obsession": Schildt G, "*Alvar Aalto in his own words*", New York: Rizzoli, 1997

⁶ Aalto Alvar, "*The trout and the stream*" [Domus, 1947], in G. Schildt (ed.) *Alvar Aalto Sketches*, Cambridge, MA: MIT Press, 1978 (1985), p. 96-98

⁷ Schildt G, "*Alvar Aalto in his own words*"; New York: Rizzoli, 1997

⁸ Aalto Alvar, *Arkkitehti*, no. XII, 1932, p.5-6

In this project can find one synthesis of many important elements of Aalto's architectural language in harmony, that are going to be *'leitmotifs'* in Aalto's future work. The first part of the thesis contains the general information about the Alvar Aalto's context and the main parts of the creative process of his first projects of Functionalism (since 1927-28) until the moment of this competition entry (1930). That information is relevant to understand the origins of his new ideas analyzed in the second part of the thesis, together with the context of this project and its general information (conditions, requirements of the program.). All this analysis of the different contexts of the architect and the competition is important for later reinterpretations from the *genius loci* of the hill "Siroki Brijeg" (*"Wide hill"*), above the center of Zagreb. Furthermore, the study examines Aalto's competition entry for this hospital complex, analyzing the six functional parts - zones, separately, with the observed new implemented principles.

Analysis of this project begins as a trip within the different space-time determinant, and can be observed as an experimental laboratory for new ideas (archetypes) of the architect where "experimentation" can be viewed as a laminated development to a *"higher level"* and final extraction of the new archetypes in this context. The main objective is searching for the meanings and the origins of the new principles, which is substantial for the creation of Aalto's architectural language, observed in the framework of a competition entry for the hospital complex of Zagreb. This project, occurs in the period of the decisive years of the Aalto's architectural trajectory evolution, from Nordic Classicism to Modern Movement (1928-1930). More precisely, Aalto's participation in competitions 1929-1930 marks beginning of the creation of his "own language" as a gradual evolution from Aalto's previously established principles of "Functionalism" in his projects of the Turun Sanomat (1928), Hospital Paimio (1929-1933), the second version of the competition entry for Viipuri library (1929) and the one part of his participation on the Turku Exhibition project (1929).

Throughout comparisons of the main ideas from this project with Aalto's previous and later works, we could understand the value of ideas and all attributes. These features could be traced as a series or chain of experience, because at the root of the Aalto's works we always find this self-feeding of his previous experience. The "leitmotif" in his work is not a formal "thing", nor one "universal solution," as the answer to many problems and requirements of some specific context and use.

This project as pointed out by some authors⁹ as one of the most extensive projects with such importance that leaves a mark on his entire career. All these authors mentioned and confirmed in their articles some "input" information previously pointed out by Schildt G. and Quantrill M., but until now without one deep analysis of this Aalto's extensive competition entry for the "hospital city" with the synthesis of all new elements observed as the principles of Aalto's architecture.

In the study are analyzed these mentioned elements together with all other new important principles from this Aalto's competition entry, and their origins and meanings in the wider context as the main theme and main focus of this study.

After these first intuitions, also confirmed from the basic existing literature and critics of Aalto's work, in the research study has attempted to analyze all existing documentation about this project (available information in several countries and from the several sources on few different languages). Relevant documentation was found in the institutions and archives of the native place of the competition in the city of Zagreb and in the different institutions in Finland, the native country of Alvar Aalto

⁹ Some major critics of the Aalto's work mentioned this innovative project: Quantrill M. in his book: *"Alvar Aalto: A Critical Study"* (1983) pointed out the Lecture Hall-Amphitheatre and mentioned daylight of lecture hall. Schildt G., in the book: *"The Decisive Years of Alvar Aalto"* (1986) confirmed these first intuitions that this project of the competition of Zagreb was one of his most extensive and creative works in the years of changing where he confirmed the new element of the amphitheatre, one new window system and the one residential building form and mentioned that the Sanatorium building as the one part of this complex is orthogonal version of the sanatorium in Paimio. Quantrill M. pointed out the new element of the lecture hall-amphitheatre and daylight, which confirmed also Weston R. (1995). After them, authors: Radovic D. (1995, 1997) confirmed previously mentioned elements by Quantrill and Schildt and added that he respected postulates of Functionalism (from his description of project), Hrausky A. (1997), (he also added in his article to previously mentioned elements, one comparison of the three clinics with Wolfsburg cultural center) and Laslo A. (2004) (he gives more details of the conditions of the competition and circumstances, general information and also some information about the site of the competition and old complex and confirmed previously mentioned new design elements); Finnish authors: M. Norvasou (2006) in his article, also mentioned that in this competition Aalto applied the amphitheatre and E. Laaksonen (2009) (Director of Aalto Academy) in his article, published in *Arkkitehti*, also mentioned and confirmed previously mentioned some elements from this competition entry.

where are performed almost all his works, relevant for this study and specially for the part of the derivations and variations of the principles applied in this competition entry, and where have been visited many works and archives of various institutions during the researches and analysis of Aalto's realized projects in Finland.

All original documents of this Aalto's competition entry (in German language) were returned to his office in Turku and saved in his Archive in Finland. With all drawings, Aalto sent one description of his competition entry, which is studied and analyzed for the first time in this thesis together with one article about this project, which he wrote and published in Review *Arkkitehti* in 1932.¹⁰ Analysis of the project is based on the 250 original drawings and sketches saved in the Archive of Alvar Aalto (132 sheets of early drawings, sketches and 18 images final drawings).

After detailed analysis of six parts of the project with all elements in the context, it is possible defining and searching for the possible origins and meanings of the eight extracted main "Principles", important in a career of Aalto as some main parts of his architectural language. The projects without an analysis and understanding of his biography, complete works, thoughts and theories and many other direct and indirect influences may not have this value itself, because we can only understand this work as an important chain of all his experiences. 1929-1930 was the important period when Aalto took a step toward his "own" architectural expression, "personalizing" the "collage" of his previously established architecture of the modern movement (1927-1929), with the implemented functionalist elements, in his first phase previously based on the Le Corbusier's principles and elementary forms.

¹⁰ Aalto's article, published in XII-1932, p56 about this competition entry

Methodology

The thesis is based on projective analysis and investigations in-situ, which includes all documents related to the theme of a study of the Aalto's project in relation with different theoretical bases. Conduct investigation comprised of an on-site visit with existing buildings of the 1930 competition context. Relevant archives and referent institutions have been consulted in order to perform reliable analysis of existing documentation in Zagreb, and this field investigation also included research visits to various Finland cities (Helsinki, Espoo, Tapiola, Otaniemi, Turku, Paimio, etc.), aiding comprehension of Aalto's realized works directly in situ and variations of these new principles from his competition entry for HCZ.

The first objective of the extensive field investigation was to find all supporting literature available in different languages (Croatian, German, Finnish, Swedish) and retrieved from the different archives. Analysis of the projects have related the use of the different theoretical basis during the study with the special focus of the own Aalto's thoughts about his design process, the theories connected with the natural processes related to the competition context, Natural Urbanism, e.g. the Spatial Theory of Nature, and general theories as the Phenomenology of space of Norberg Shulz, Heidegger's theories and more contemporary theories of Steven Holl, related to the place. In the last part of the conclusions also are used some theories of Platonic form/idea and the "universal substance" of the variations of these first principles along Aalto's trajectory. During this research, valuable documentation from the Archive of Alvar Aalto was consulted and analyzed, where two hundred and fifty original drawings of the competition for the hospital complex of Zagreb, are archived in Aalto's Archive in Finland and also published in the official book of Finland Museum and Museum of Alvar Aalto, G.Schildt: *"Architectural Drawings of Alvar Aalto 1917-1939"* (Volume 5).

For the better understanding of Aalto's new ideas and features applied, it was necessary analyzed not only previously realized projects, but also to carry out parallel studies of interactions between the different projects that were realized simultaneously with the competition entry of the hospital complex of Zagreb.

This project was also influenced some of the future modifications of Paimio hospital

complex during its final phases of the project realization and the future extensions of the complex in 1950's (annexed parts of the ground floor) analyzed in the last part of the study, VI zone.

Also, at the same time with this competition entry of Zagreb hospital complex, Aalto has organized the Exhibition of the Minimum Dwelling in the Helsinki in the autumn of 1930 as the answer of the CIAM with the main themes of the residential architecture, held at the same time with the CIAM in Brussels (1930). All that information helps us to understand his new ideas in the framework of the Zagreb competition project. His presentation at a Helsinki exhibition, on the residential architecture puts the new light on understanding the new ideas of the residential buildings and ten-story tower with the stepped form of the floor basis, developed at the same time of the Helsinki Exhibition, for the medical staff of the Zagreb hospital complex, and which form will be applied later in almost all of his residential buildings and as the one of the main components of the Aalto's architectural language.

Theoretical and design approach used within this study thoroughly elaborates the origins of the new ideas, important for the creation of Aalto's architectural language (personalization of the collage of the first ideas of Functionalism after the 1928/29). This research enriches the existing knowledge base and background about the origins of important elements of the architectural language of Aalto.

Structure and content

The thesis contains the three main thematic units: two introduction parts of the both contexts: **I** Aalto's context, **II** Context of the competition and **III** Main part of the analysis of the Aalto's competition entry, with six main zones and eight new principles "extracted", observed and analyzed from this project separately with parallel analyzed their interactions and future variations and derivations along the Aalto's trajectory. The last part of the study contains three groups of the conclusions groups: 1. new principles, 2. variations as a "universal substance" and 3. elementary forms as the main constitutive elements of Aalto's architectural language and their transformations along his trajectory, connected with the spatial theories directly "extracted" from nature.

The first part deals with the context information about Aalto's beginning of the creation of his fundamental principles, the guiding paths until the year of the competition, with some of the unrealized competition projects, important to the creation of his own architectural language, after first Functionalist projects (1928-1930). Also, this part contains one general description about his projects for the health buildings.

The second part brief describes the context of this international competition in Zagreb, its participants and conditions, CIAM with its representative from Yugoslavia and also includes the general information about the competition program.

The third part is the main pillar of this study and contains a different analysis of the Aalto's proposal for this competition, in the framework with the different theories as the Spatial theory from Nature, theories of N.Shulz, M.Heidegger, Häring, Le Corbusier, S.Holl and Aalto's thoughts. This main part of the study is divided into six main independent chapters, as the six functional parts of the hospital complex (I-VI), where each of Aalto's new principles is exhaustively analyzed in the specific context of the place and the specific domain of use. Throughout the development of six main parts of this hospital complex, we can conclude that Aalto is incorporated into this project eight important principles (PR 1-8). These principles are found in almost all of his future works, where the word "principle" is used in the broadest sense of his architectural language.

It is not limited only on the formal compositional study, but it is a more complex search for the origins and theories based on their connections with the ancient cultures, connection to place, genius loci, metaphorical - symbolic and functional meanings, etc). Alongside the analysis, variations of these principles are considered that are frequently encountered in Aalto well-known works. At the end of the investigation, we can prove and verify the initial observations about the origins and meanings of the some important elements of Aalto's architectural language and their variations in his future works.

In this competition entry of Zagreb Aalto adopted all aspects of modern, functionalist construction, with most favorable orientation for ventilation, insulation and wind protection on the hill, parks and private gardens between the buildings, thinking about the health, well-being and the perfect functions of spaces for the different users of the hospital complex with the spaces of the University of Medicine (employees, patients, teachers, students, visitors). Aalto wanted to provide the privacy and tranquility of each zone for the patients and, also, in his proposal he gives the same value to the dialogue with the natural context together with the context of the site which contains the old clinic buildings and the more wide context where he established a dialogue between the hospital complex on the hill and the city.

I AALTO'S CONTEXT

Aalto's drawn thoughts

Alvar Aalto was an intuitive architect and artist who believes in the strong connections between the architecture and art, based on the "crystallization" of the idea in the creative design process. He has sought inspirations often from the "non-objective" world, subconscious and unconscious from his mind as the associations from his interactive memory. His early sketches of the development of some project we can often relate to the ideas captured from his travels which are a continuation of his thoughts and theoretic base which show us the main motives and spatial concepts which "occupied" his mind in some specific moment and place. Aalto appreciated theater, cinema, film, arts, photography, drawing where his sketches, made during his travels, reflect the "own" subjective perception of reality with the own experience, which based on the thoughts and previously saved associations in his memory.

Mark Alan Hewitt described the significance of the contour in Aalto's sketches as: *"The concept sketch, encapsulating may of the formal, theoretical and phenomenological aspect of a design in a single stroke, now occupies a prominent place in the canon of architectural representation. The sketch is fresher, more vivid, more personal than the mechanistically produced presentation drawing"*.¹

The sketch is a personal reinterpretation of the reality, not a "copy" and often contains some intuitions and future solutions of some projects, as a "universal substance" which gives the balance to all elements in the process. Sketches give inspirations and "spirituality" and often hide the exact meaning of something that only could be known to its author and frequently there we can find the true origin and meaning of the realized idea, as in the case of this Zagreb competition entry where we can confirm that early drawings "hide" many of his main ideas realized in his later works. In the analysis of the characteristic composition of the circle and rectangle component in the movement of the clinics of this competition entry, we could probably connect that compositional idea with the new window system and sketches which he developed in that time.

¹ Hewitt M. *Imaginary Mountain: The Significance of Contour in Alvar Aalto's Sketches*, Yale University, 1989

All these sketches could show us more information on the base of the imagination of the architect, always served to a human as the perfect solution between different needs. Many of that perfect solution coming from the subconscious connected with some specific context.

Aalto explained his creative process of the main ideas of the interior of the Viipuri library project²: *“When I designed the city library at Viipuri (I had plenty of time at my disposal, five whole years) long periods of time I pursued the solution with the help of primitive sketches. From some kind of fantastic mountain landscape with cliffs lit up by suns in different positions I gradually arrived at the concept for the library building. The library’s architectural core consists of reading and lending areas at different levels and plateaus while the center and control area form the high point above the different levels. The childish sketches have only an indirect connection with the architectural conception, but they tied together the section and the plan with each other and created a kind of unity of horizontal and vertical structures”*³.

In this research, the main source of the information about the Aalto’s contemplation is discovered by analyzing the first sketches of Aalto’s initial ideas (many of these drawings are early sketches (250) and just 18 sheets are final drawings of the competition delivered). For the current study the early sketches have the same and in some cases even higher value than his final drawings, which show us the purified idea and the complete thought genesis. By analyzing these first, early sketches it is possible to decipher what was the original idea connecting with the other contexts, before the final presented drawing. In this study of his early sketches, it is analyzed what happens in the watchful eye of the author when the accumulated, unconscious and subconscious level from some previous experiences before and after are regarded in the context.

² Aalto in the period 1927 -1933 made many modifications of the Viipuri library project, from the first competition project with classical elements to his representative work of his own organic architectural language. This competition entry of Zagreb is situated in the middle of this path of the transformations (his 2. Version of the Viipuri library, 1929-1930), (also in the middle of the path of the modifications and extensions of the Paimio Sanatorium (1929-1933)

³ Aalto Alvar, *The trout and the stream* [Domus, 1947], in G. Schildt (ed.) *Avar Aalto Sketches*, Cambridge, MA: MIT Press, 1985, p.97-99

Aalto's written thoughts

We learn about Aalto's own theories from his written thoughts, which are mostly all captured from his conferences and elaborated and written by Göran Schildt together with Archive and Museum of Alvar Aalto, in three volumes of the books from different periods of Aalto's career: *Early, Decisive and The late years* (1984-91). The collection of Aalto's written thoughts could be found in the book of Göran Schildt: *"Aalto in his Own Words"*, published by Rizzoli (1991).

In parallel of this study: "drawn thoughts" and "written thoughts" of the author are analyzed both as necessary parts of the complete research and understanding of his creative process, origins and meanings. Aalto developed some of the important ideas of his architectural language in this competition of Zagreb, but he realized some of these ideas many years after, as in the case of the Amphitheater, which he realized more than 30 years after, and which is the probably main "leitmotif" during his trajectory.

This long process to realization we can understand from Aalto's words where he explains that architecture needs time to "crystallize" the idea, more than other creative works: *"Just as it takes time for a speck of fish spawn to mature into a fully-grown fish, so we need time for everything that develops and crystallizes in our world of ideas. Architecture demands even more of this time than other creative works"*⁴ Heidegger, also described the birth of the genuine craft with the biological metaphor and just like Aalto, he pointed out that creative work requires training and time: *"At times it (the meditative thinking) requires a greater effort (than calculative thinking). It demands more practice. It is in need of even more delicate care than any other genuine craft. However, it must also be able to bide its time, to await as does the farmer, whether the seed will come up and ripen"*⁵ This "meditative thinking" is very important and productive and it is opposite to the "calculative thinking".

⁴ Aalto Alvar, *The trout and the stream* [Domus, 1947], in G. Schildt (ed.) *Alvar Aalto Sketches*, Cambridge, MA: MIT Press, Translation by Stuart Wrede, 1985, p.98-99

⁵ Heidegger Martin, *Memorial address in Discourse on Thinking*, trans. J. M. Anderson and E. H. Freund, New York: Harper and Row, 1966

Aalto explained the value of the "development process to a higher level", which could compare with the Heidegger's "meditative thinking", as a creative process where it is less important if some work is realized. This "meditative thinking" requires more time as the: "development process to a higher level". When we "meditate" we consider our being, our singular subjective truths, and our meaning of the things. This kind of truth is what Heidegger seems to imply in his "Discourse on thinking" as the authentic. Calculative thinking requires a substantial drawing from the external world, the world of the "they", and it is collective thinking - inauthentic. Aalto participated in many competitions without any instant recognition, but in each project he was developing the new ideas and all these ideas as the individual kind of truth, with the own meaning of the things, together formed his "base" of the interactive memory, as an indispensable source for finding the best solution:

"Basically, architecture is not only a certain quantity of built and finished results but a laminate development process to a higher level, which, together with the inner interaction, continually creates new solutions, new forms, new materials for the construction and constant changes of the constructive ideas".⁶

Aalto was inspired from his travels to Italy and the small old cities of the terraced Toscana landscape and during his design process, he always travels to Italy:

"I do not want to mention any particular trip; they always keep in my mind a trip to Italy. Maybe this is a trip I've ever done, and that is still alive in my memory, or perhaps is the current trip or some trip to do later. A trip so probably needed a "conditio sine qua non" of my work"⁷

"Ancient city" become for Aalto his "obsession" and "religion":

"Ancient city" has become to mean to me something like a religion, illness or insanity. The city of hills, with its live, wavy lines, following an unexpected path, previously unknown to mathematicians, is for me the incarnation of the difference between the brutal mechanization of life - whose manifestation in the modern world is the prevailing ugliness - and religious beauty. I see it just the everyday and the sublime time, the art, the way that modernity does not in any way create, but tries to avoid with all his might. (...) its aesthetic value emerged as an independent result of the whole process; Like the beautiful strokes, full of culture, Mantegna Fresco".⁷⁻¹

⁶ Alvar Aalto, Paper read at the Nordic Conference of Building in Oslo, 1938, ARK, 1938

⁷ Schildt Göran, *Alvar Aalto in his own words*, Otava Publishing Company, Ltd., Helsinki, 1991 (Ed.1997). Traducción al español: *"Alvar Aalto de palabra y por escrito"*, El Croquis Editorial, Madrid, 2000, p.57

⁷⁻¹ Ibid., p.67-68

He also described terraced hillsides of the site of the new hospital complex, which help us to understand his future ideas of the terraced forms ("Ziggurat") in the vertical and horizontal plane, very characteristic elements of his architecture language in his future works:

*"Admiration for, and a deeper knowledge of our old, indigenous architecture and our former values would appear to be a relatively late date in this country (Finland), but so deeply rooted among us "professionals" that we are now actually found in them a basis for our work."*⁸

Aalto during his initial classic phase did not speak about classic motives or the some copy of the past architecture, he gets inspired by a small medieval church or vernacular architecture as something which came from "primitive" :

*"When we visit a medieval church, look at an old manor house, or contemplate a hundred-year-old vernacular building, we find that there is something that reaches out to us, a mood. It may be caused partly by handcrafted surfaces, by the building materials artistic purity, by the simple lines that harmonize with the landscape..." "I am led to believe that most people, but especially artists, principally grasp the emotional content in a work of art. This is especially manifest in the case of old architecture. We encounter there a mood so intense and downright intoxicating that in most cases we do not pay a great deal of attention to individual parts and details if we notice them at all."*⁹

Aalto stressed that details are not important of the old forms as a "artistic purity" and that we do not notice them, but the pure form which creates our "mood".

⁸ Aalto Alvar, "Menneitten Aikojen motiivit" (Motifs from Times Past) published in Arkkitehti, 1922

⁹ Ibid

Alvar Aalto and guidance paths in the years 1929/1930

Aalto those years is moved from Jyväskylä to Turku, center of the new movement in this time, and did a step ahead from his "classical" phase toward the modern functionalist movement through his contacts with architects of the modern movement as Erik Bryggman and previously with Sven Markelius. In 1927, Aalto participated in the competition of the League of Nations in Geneva, where Le Corbusier took a part as well, and by analyzing the Le Corbusier's project of this competition, one can deduce that there is existing concrete and definite inspiration of his future composition made by connecting the components implemented in 1929, at the project of the Paimio Sanatory and also on this case study of the Hospital Complex project in Zagreb a year later.

In 1928, he traveled to Paris and also visits Denmark and Holland (where he saw works by J. Duiker, J.J.P. Oud, W. Dudok, A. Lurçat, A. Roth, Le Corbusier, and others). It is an important influence of the J. Duiker on Aalto's principle of "decomposition" or architecture made by segmentation. Later he participated in the Second International Congress of Modern Architecture (CIAM) in 1929 in Frankfurt, where he came across the L. Moholy-Nagy, W. Gropius, Le Corbusier, S. K. Moser and Giedion.

In just a year and a half after his last classic style project and the first versions of the Vipuri Library project (1927), Aalto realized the three works that initiated the breakthrough from the previous classical period characterized by influences of Nordic classicism and National Romanticism: the building for the Turun Sanomat in 1928, the Sanatorium in Paimio (competition 1928-January 1929 and subsequent realization with the modifications until 1933) and he realized also one part of the project of Exhibition of the seventh centenary in Turku, 1929 (elaborated by his colleague Erik Bryggman) which would be also influential a year later in the urban composition of Aalto's competition entry for the Zagreb hospital complex (1930-31). At that time of this competition entry, Aalto worked at the Turku office with Erick Bryggman, another big follower of Functionalism in Finland. In the year 1929 Aalto participated in the II Congress of CIAM in Frankfurt and at the same time he also had a very close contact with the Soviet Constructivist movement, as the one architecture movement linked with the Suprematism

represented by Kazimir Malevich, Lisitzky and others, focused on basic geometric form, as well as with the modern movement led by Le Corbusier, Mies Van de Rohe, Gropius and the Bauhaus school. That results in a new path of his future works as a fusion of all contemporary movements of that time interpreted in Aalto's own original "organic" way with implemented all elements of conscious and unconscious from his memory and the specific context, which we will observe on this HCZ competition entry.

Aalto, after his Classicism phase until 1928, continued to have influence of main Nordic architects such as Sven Markelius and Asplund. That can observe within the urban composition of the hospital complex in Zagreb and equally in the way that Aalto achieved a great monumental form using the basic forms as in the case of the Asplund's Stockholm Library (1922-24). Asplund important influence on Aalto is reflected in the creation of the sacred and spiritual aspects of space, as in the Ancient Culture of Egypt, Mesopotamia, Greece or Rome, using the elementary forms and the "spiritual" and "illusionary" light and "sacred" character of the interior.

In the same year of this competition, in 1930, Aalto visited the Exhibition of Stockholm, where Asplund was the main architect, but now implemented the principle of Functionalism. This exhibition had a great impact on the architectural styles known as Functionalism and International style in the Scandinavian countries where the exhibition's slogan was: *Acceptera!*, or *Accept!*, which mean the final acceptance of Functionalism, standardization in Architecture, not just as the architecture new movement, but also as a cultural and social change.

Aalto analyzed very positive effect of the set of the buildings of the modern movement, specially as a "social" phenomenon and "cultural change" that he observed at the Exhibition in Stockholm, held at the same time with the Zagreb hospital complex competition (August 1930-January 1931). That information is important to understand his modern functionalist ideas applied by the basic forms and the "standardization" and the new technology of the building applied on the Zagreb competition entry.

*“Designs that are drawn up for a genuine purpose, but are not built, often give us a more interesting and accurate view of the designer’s range of ideas than completed works. Because they are unfinished, the architectural ideas in them are often clearer than in works that are eventually built after compromises have been made and the financial decision taken. Competition entries are usually drawn up against a very tight schedule, in a search for an overall concept, and even an unsuccessful competition entry may have the power to open up new avenues of approach, new themes and new forms for the architect, that can still be used long after the competition is over. Competitions are thought of in the profession as “continuing education projects”.*¹⁰

Aalto in his career worked on more than 500 projects and only about 200 he had realized and if we want to understand his main ideas and the principles of the realized works during his career, it is very important to know the origin which can be often found in his unrealized competition entries.

One of that unrealized projects, in the period 1929-1930, is the Project of the Competition entry for the G.A. Serlachius Co. Headquarters (1929) (Fig P4), which floor plan has an observed as a characteristic composition of the wedge-shaped segment of the one part of the circle, where Aalto created the courtyard in the form of the triangle between the two rectangular forms of the buildings. The wedge segment as an individual form of the floor plan can find, also, two years before, in the competition entry of the Pärnu Spa building of Estonia (1927), his first international competition project; this shape indicates his first steps of the creation of his architectural language, which will be further analyzed in this study.

Another unrealized project, which also influenced his architectural language of the acoustic architectural elements, is a competition entry for Valilla Church in 1929 (Fig P5), and the composition that he used on this project, he will consequently use in Temppeleaukio Church competition entry. The most interesting elements are wedge-shaped floor plan and new acoustic form of ceiling curving down to the floor behind the altar that was observed here for the first time.

¹⁰ Laaksonen Esa, *Drawn in Sands, Unrealised visions by Alvar Aalto*, Alvar Aalto Museum, Allvar Aalto Academy and Museum of Finnish Architecture, Helsinki, 2002, p.3



P4

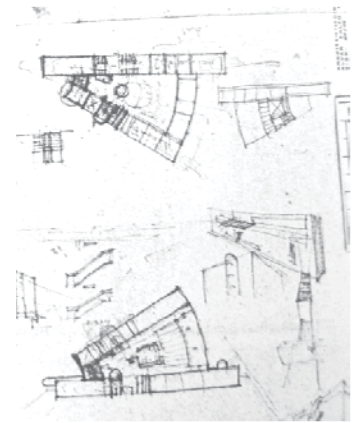

P4a

FIG P4 - Competition entry for the G.A. Serlachius Co. Headquarters, 1929 (Unrealized project), (floor plan, section and façade).Aalto, source: Schildt, 1994a (AAA)

FIG P4a – early drawings, 60/55,AAA

FIG P5- Competition entry, Valilla Church, 1929 (unrealized project), Aalto, source: Schildt, 1994a (AAA)

FIG P6 - Competition entry for the Tehtaanpuisto Church, 1930 (Unrealized project), Aalto, source: Schildt, 1994a, (AAA)

In the first competition entry of the Tehtaanpuisto Church in the September of 1930. (Fig P6), one year after the competition entry for Valilla Church, Aalto used the analog floor plan and the ceiling system. Aalto was not awarded with the project realization for the Villa Church because the jury criticized the entry because the acoustic passage of sound was directed one way only.¹¹ For the improvement of the acoustics of this church's interior, he finally created in the Tehtaanpuisto Church project the special system of the acoustic ceiling with the semi-cylinder segments, where he created a two-way passage of sound waves between the altar and the organ loft.¹² An analog ceiling system with acoustical properties, we can see also on the ceiling of the Viipuri library hall.

By analyzing all drawings of Aalto's projects from this important period of change, it is sure, that one of the most interesting unrealized competition entries of this part of his trajectory and the beginning of the creation of his characteristic architectural language, which contains one synthesis of his main principles, later performed, is this a vast, unawarded competition entry for the Hospital complex of Zagreb (1930/31).

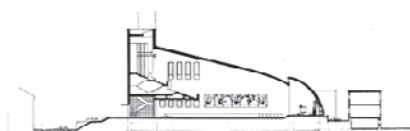
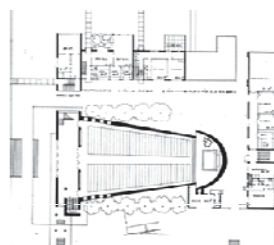

P5

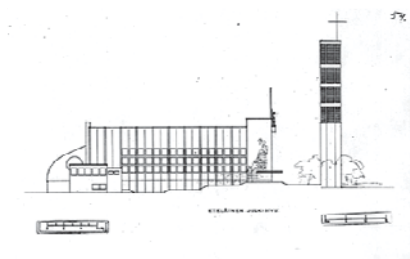
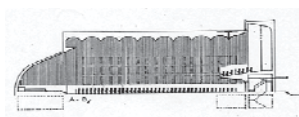

P6

¹¹ Schildt G., 1994, p.46

¹² Ibid.

Aalto's Health Buildings

*"Aalto did not think of physical health as an isolated phenomenon; the Classical principle - mens sana in corpore sano - (a healthy mind in a healthy body), he considered as the main principle of his work, physical well-being as the basis for mental well-being."*¹³

In the second half of 20's and 30's were built many sanatoriums all over the world and Aalto participated in a few competitions for the sanatorium buildings. In July 1927, he participated in the competition for the Kinkomaa Sanatorium in Muurame Kinkomaa (Fig P7), near to his home city, Jyväskylä. This Aalto's competition entry "was the first design to clearly reveal his "conversion" to Functionalism".¹⁴ He applied his main idea of the collage-building which contains four different rectangular pavilions organized in an orthogonal system. G.Schildt described the composition of this Sanatorium: "The basic idea is a flexible division of space into four separate, but closely linked building masses, set at right angles."¹⁵ Aalto won the first prize in the competition for the Sanatorium Paimio (1928/9) (Fig P8a,b). This building respected all characteristics of the Functionalism, and at that moment Aalto, as one of the members of CIAM, has converted to the architectural elite, recognized internationally by all future congresses CIAM.¹⁶

In this project is evident big influence of the Functionalism architecture of Le Corbusier and Walter Gropius and special influence of the ideas of the Dutch architect J. Duiker (his sanatorium Zonnestral, which Aalto visited in 1928 before the competition of the Sanatorium in Paimio). Düiker's sanatorium composition, together with the previous Aalto's sanatorium project of Kinkomaa (1927), influenced the composition of the Sanatorium Paimio, as the biodynamic-composition made by different parts of the body connected in accordance with the best orientation of each part of the body to the optimal source of daylight, towards the sun as vegetation in nature.

¹³ Schildt Goran, Alvar Aalto: The Complete Catalogue of Architecture, Design, and Art, New York: Rizzoli, 1994, p.67

¹⁴ Ibid., p.68

¹⁵ Ibid., p.68

¹⁶ At the same time with this competition entry for the hospital complex of Zagreb (1930), Aalto was developing the final project and some modifications of the Paimio Sanatorium (1929-1933), where are analyzed the interactions between both projects in the last part of the study.

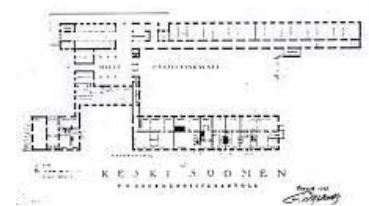

P7

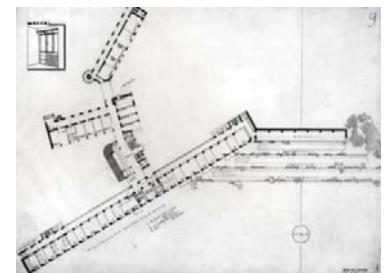

P8a

FIG P7 – Floor plan of the Kinkomaa Sanatorium (1927), unrealized project, Aalto (influence of the composition made by parts, the same orthogonal composition as the Zagreb Sanatorium building), source: Schildt, 1994a, AAA

FIG P8a - Floor plan of the Paimio Sanatorium (1928-29), in the first version it is observed the composition without annexed forms of the ground floor (heating plant and other annexed spaces), developed at the same time with the Competition entry for Zagreb hospital complex. source: Schildt, 1994a, AAA

FIGP8b - Hospital complex in Paimio today

FIG8c - Kälviä Sanatorium (spring, 1929), Aalto, source: Schildt, 1994a, AAA

In this research is visited the building of the Hospital in Paimio, also very functional nowadays, placed in the characteristic Finnish forests as the best environment for its patients. The building after few adaptations of the spaces, during more than eighty years, from the first use of the Sanatorium for tuberculosis, became a very functional hospital today. For the research of HCZ project, it was important to comprehend the ambiance which Aalto created and the way how he thought about the architecture for the best comfort of the patients with tuberculosis which spent months in this hospital. During investigations has been visited, also, the residential part of this complex, which Aalto designed at the same time with the HCZ competition project (and at the same time with the Exhibition of the Minimum Dwelling, organized by Aino and Alvar Aalto at the same time with this competition, in autumn 1930 in Helsinki).

Important influence on the part of the HCZ project, is evident on the example of building of the Sanatorium in the north of the complex, (Plot III) where Aalto developed the Sanatorium of Zagreb as the orthogonal version of Paimio Sanatorium, due to the climatic condition of the site (as the second version of the total of four versions which he did for the Sanatorium of Paimio), and also similar to the orthogonal composition of the previous competition entry for the Kinkomaa Sanatorium (1927). The building of the Sanatorium of Zagreb influenced some modifications and the extension of the Paimio Hospital in 50's.¹⁷

After the competition project of the Sanatorium in Paimio, Aalto participated in few other competitions for the health buildings, but he did not win any of those competitions: Kälviä Sanatorium (spring,1929) (Fig 8c), Competition entry for Zagreb central hospital, Yugoslavia (1930/31(15th January)), Health Center for the Ahlström company in Noormarkku (1944) or planning competition for the Kivela hospital complex in Helsinki (1950).

¹⁷ Interactions between both projects of the Sanatoriums in Paimio and Zagreb - Analyzed in the Zone VI of the complex, last chapter of the analysis of the study.



P8b

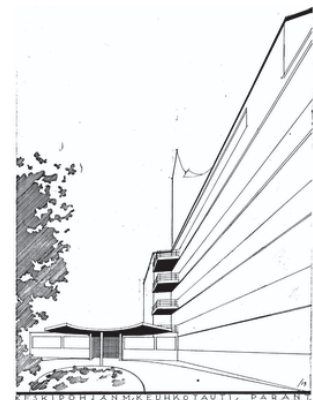

P8c

In this competition entry for the Kivela hospital complex (1950), named “*Corpus*” (Fig P9a,b) Aalto developed the project in the similarly built context of the HCZ competition, where he needed to connect the new hospital complex with old existing buildings on the site. He applied the similar underground main system and the free traffic circulation inside the complex by the original system of tunnels, as in twenty years earlier Zagreb hospital complex. The jury, as in the case of the Zagreb hospital complex evaluated that solution as the “impossible”.

After this project of the Kivela health complex in Helsinki, not awarded any of his three competition projects for: Glostrup Hospital in Copenhagen (which Aalto named “1,2,3,4,5”, probably because the number of his participations of the competitions for the health buildings without success), and two last projects of the health center of Alajärvi and Health spa in Reykjavik, Iceland.

The ironic fact is that Aalto participated in a large number of the competitions for the hospitals, and that as an architect who deeply cared for the well-being of the patients and the highest values of human comfort did not achieve any success in the competitions of the national and international level. Only in the performed famous Sanatorium Paimio we can observe some of his very human ideas of the health architecture.

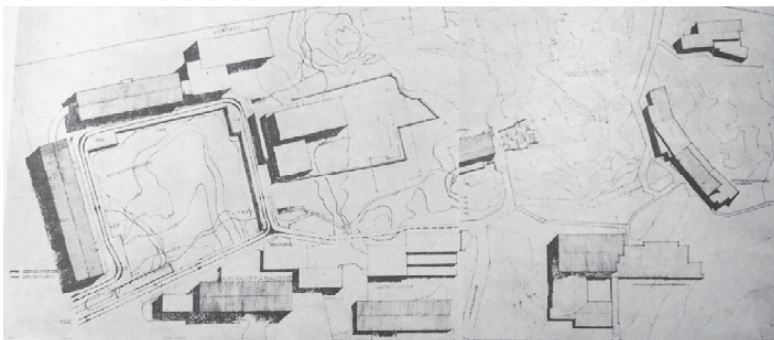

P9a

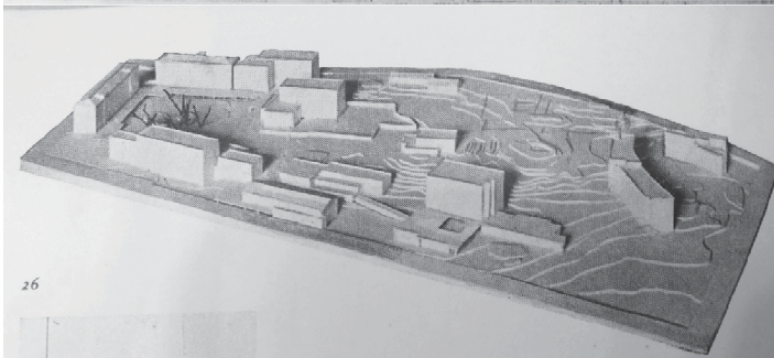

P9b

FIG P9a,b - Competition entry for the Kivela Hospital Complex (situation plan (P9a) and model (P9b)), Helsinki, Aalto 1950, source: Finnish Architecture Museum, Helsinki, *Arkkitehti* 8/1951, 26

One year before the competition of the hospital complex in Zagreb, in 1929, Alvar Aalto collaborated with Erik Bryggman on some parts of the project of the Seventh Centenary Exhibition in Turku (open-air acoustic stage, the main entrance, advertising stand, design of the information stand, etc.,..)¹⁸. Aalto worked together with architect Erik Bryggman in the office since 1927, moving from Jyväskylä to Turku, in the period of his evolution from the Classicism to Modern Movement and Functionalism. Turku exhibition project is planned on the hill *Samppalinna*, as one complex of orthogonal arrangement where pavilions of the exhibition had a simple, rectangular form and a round form building of the restaurant by the end of the main route of the Exhibition. This plan of the Exhibition was developed by Erik Bryggman, with signature of Erik Bryggman observed on all plans of the complex and just without his signature on the plans of the one pavilion and the entrance, open-air stage, advertising elements, some furniture, where some of these drawings have Aalto's signature. This Bryggman's general plan of the exhibition will be influenced the ideas of the HCZ competition project and general urban plan based on the systems of the parallel individual pavilions. Also, both sites have very similar natural environment, Turku Exhibition site with sloped hillsides and the hospital complex site on the hilly terrain of Zagreb. (Toscana landscapes - permanent Aalto's inspiration).

At the same time with this competition entry, Aalto developed the plan of the industrial complex of the Toppila Vaara (1930-31). This project contained a composition with the complex system of the installations, where he applied new forms of the industrial buildings with the strong plastic character, which would influence the composition of the service area of the hospital complex of Zagreb. Aalto wanted to create the health complex as a set of medical and architectural effort, and for that goal, he made an open system with an external communication plan, which aims to penetrate the nature and natural medicine to the hospital complex. Thinking about these spaces for the rest and health regeneration in that way creates this hospital complex as a symbol of ethics and humanization. An important role in the whole composition was the "green" base, a forest or a mountain in the case of the Hospital of Zagreb, a condition which permits an urban layout that is integrated in a natural way.

¹⁸ Schildt, City of Turku 700th Anniversary Exhibition (1929), 1994a, p.31

This urban composition is a reflection of all ideas of the new cities of Functionalism based on the orthogonal general system of the urban plan, responsive architecture to the climatic conditions, sufficient gaps between the pavilions, with green gardens, project possibilities in the application of double diffused indirect daylight from the two sources; upper sidelight and skylights filtered by the conic light entrance.

The urban composition of the HCZ project - "green city" Aalto described as the Hospital park with the individual pavilions in the green zone on the hill, free of the traffic. That urban composition plan was characteristic of the Russian cities plans after the Russian Revolution (1917), where during the 20's series of the urban plans were realized as the radical social and aesthetic renewal of the society. International architects as Ernest May and Hans Meyer also participated in these urban projects which tendencies followed Bauhaus and International style. Also, it is visible influence from the Stockholm Exhibition (1930), where Aalto was very inspired after his visit, at the same time with the HCZ competition entry, and where he explained the positive effect of this modern space on the human well-being.

For the CIAM III in Brussels, Aalto made one example of the urban plan of the modern Functionalism residential block in Turku with "L" form of buildings, creating the green zones, rectangular courtyards between four buildings of the block. In *Domus* in 1930, Aalto connected the science and architecture design: *"A dwelling is an area which should offer protected areas for meals, sleep, work, and play. The **biodynamic functions** should be taken as points of departure for the dwelling's internal division, not any outdated symmetrical axis or "standard room" dictated by the façade architecture"*. About the city and the new inside the existing city context, Aalto stressed: *"Each building is built according to the zoning codes so that it is by the established architectural scheme and harmonizes with existing buildings. It should be pointed out that neither medical science nor any other natural science accepts an equivalent technical archaism."*¹⁹

¹⁹ Quoted in Schildt, "Sketches", 1978, 29-30, originally published titled: "The Dwelling as a Problem", *Domus*, 1930

In this competition entry of Zagreb Aalto adopted all aspects of modern, functionalist construction with most favorable orientation for ventilation, insolation and wind protection on the hill, parks and private gardens between the buildings, all thinking about the health, well-being and the perfect functions of spaces for the different users of the hospital complex with the University of Medicine(employees, patients, teachers, students, visitors). Aalto wanted to provide the privacy and tranquility of each zone for the patients and also in its proposal he gives the same value to the dialogue with the natural context, with the context of the site which contained the old clinic buildings; and the city context where he established a dialogue and strong link between the hospital complex on the hill and the city.

II COMPETITION CONTEXT

2. "ACCEPTERA" / CIAM Yugoslavia / Competition Program

"Acceptera" - Zagreb

Years before this international competition for HCZ in the city of Zagreb was implemented the main principles from Modern Movements which confirm, also, Peter Behrens, who in 1927 reconstructed the Elsa Fluid building in the center of Zagreb, house by the architect Vjekoslav (Alojz) Bastl (1905/6) (Fig P10), applying the principles of the modern movement (Fig P11). This project Behrens realized at the same period with the project of the residential complex of the Modern Movement "Weissenhofsiedlung" in Stuttgart, 1927. This information shows that the slogan "Acceptera" from the Nordic architecture, advertised in the Stockholm Exhibition (1930), was previously "implemented" in the architectural context of Zagreb, three years before this competition and that this international competition only confirmed previously established ideas of the Modern Movement and Functionalism.

In 1929, the government decided to move the oldest hospital of the city (1804), the holy sisters Foundation Hospital. The city didn't have adequate hospital center with the general hospital, specialized clinics and University of Medicine, to respond to the functional and technological requirements "of the twentieth century". Only a part of the complex of the Clinics of the Medicine University campus was accomplished by 1930, designed by F.Gabric (1917).¹ The buildings of the old hospital complex with the University of Medicine on this site began to build ten years before deciding to make this HCZ international competition. Although some buildings of this old hospital complex have been built at the beginning of the development of the Modern Movement (1917-1929), we observe that they contain the neoclassical elements.²

¹ More information about the context of the Competition for the Foundation Hospital and Clinics of the University of Medicine in Zagreb (1930), from the Article with the same name by Bjazic K. Tamara, published article in "Prostor" (2012) and also these general information of the Competition could be found in the article of A.Laslo in Oris,2004.

² These forms of the old clinics of the campus of the University of Medicine, existed on the site of the competition for the new Zagreb hospital complex, will be important references to creating new compositions of the clinics buildings in the Aalto's competition entry. (View in the chapter I of the Analysis of the project: Chapter 1 : Clinics and the New Principle 1 : *Head and Body* in Bio- Movement and Principle 2: *Amphitheatre*)

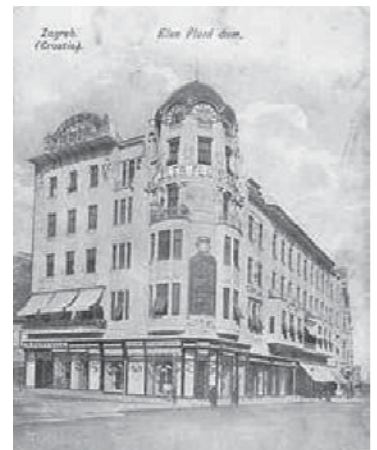

P10



P11

FIG P10 - "Elsa Fluid", Zagreb, 1905, Alojz Bastl, source (https://commons.wikimedia.org/wiki/File:Alojz_Bastl(visited10.4.2012)
FIG P11 - . Reconstruction of the building "Elsa Fluid, Zagreb, 1927, P. Behrens, source: (<http://www.ostarchitektur.com/kroati-en-croatia-1900-1945.html#18>, visited 10.4.2012)

A year before this international competition, Croatian old hospital, on the central square of the city (1929) was demolished. The new hospital was previewed by the new Regulatory plan of the city (1930), and an important part of the regulation was this site of the hospital complex on the Salata's hill.

As can be observed from these references the principles of the Modern Movement in architecture were well present in Zagreb since its initial phase, and where in the beginning of the twentieth century, many Croatian architects collaborated with several offices of the international architects with worldwide recognition at that time, as an award-winning architect in this competition, Ernest Weissmann, who collaborated since 1927 in the office of Le Corbusier in Paris. Ernest Weissmann who won HCZ competition, couldn't realize this project due to different issues after this competition and, also that was one of the main themes to discuss on the CIRPAC in Barcelona, 1932.

Mumford said on the CIRPAC in Barcelona 1932: *"Two projects were displayed, the project by Weissman for the HCZ and Le Corbusier's entry to the Palace of the Soviets competition"*³; where Ernest Weissmann also collaborated with Le Corbusier on the Centrosoyuz project during this competition entry of Zagreb hospital complex. This Congress, held in Barcelona, has not solved the problem and the Hospital Complex with the Foundation Hospital and Clinics of the School of Medicine of Zagreb has never been performed on this site, where today there are located the buildings of the city sport complex and where the buildings of the old complex of the Clinics of the University of Medicine, still have the similar uses.

³ Mumford, E., *The CIAM Discourse on Urbanism, 1928-1960.*, Cambridge, Massachusetts & London, England, 2000

CIAM Group of Yugoslavia. Representative Ernest Weissmann

Ernest Weissmann started to collaborate with Le Corbusier after his studies in the office in Paris since 1927. At the CIAM II held in Frankfurt 1929, Le Corbusier supported Ernest Weissmann, his colleague, to starting to form and organize the group for the CIAM from Yugoslavia and represent that group. After several attempts in 1929, the Group is finally formed 1932. Since 1929. (CIAM II) Ernest Weissmann was a member of the CIAM and since 1930 and the third conference of the CIAM in Brussels, he has also become a representative of the CIRPAC. It is possible conclude that this international competition for the hospital complex in Zagreb was very important, where some members of the CIAM were also participants in this international competition published in many international reviews, which helped to internationalization of the modern movement ideas.

A book called "*Problems of Contemporary Architecture*" ("*Problemi Savremene Arhitekture*") by Stjepan Planic was published at the same time before the Group from Yugoslavia for the CIAM was officially established in 1932. This book contains articles written by some Croatian architects and four architects from Belgrade, and contains some important competition and realized project of the architects from Yugoslavia, where we can find, also, published some competition entries from this International competition for the hospital complex of Zagreb (1930/31), short description about some proposal ideas of this competition and some drawings and photos. As the Introduction of this book is published Declaration from La Sarraz, for the first time publicly presented in Croatia.⁴ In this book is published also the proposed project for this international competition, by Ernest Weissmann, one of the three *ex aequo* awarded, which project should be built, but finally because many problems presented at the CIRPAC in Barcelona 1932, and without solutions, was never performed. Weissmann's project confirmed new ideas of the standardizations in the architecture with applied main features of the Functionalism and Modern Movement; most other members, also implemented in their proposals new ideas of the Modern Movement.

⁴ More details about the Group Zemlja and formation the CIAM group from Yugoslavia: Bjazic T., "*Zagreb Group-Foundation and Public Activities in Croatian Cultural Context*", Prostor, Zagreb, 2005, p. 41-51

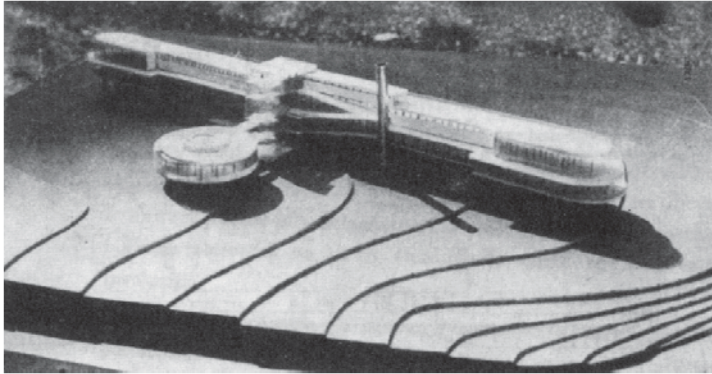

P12

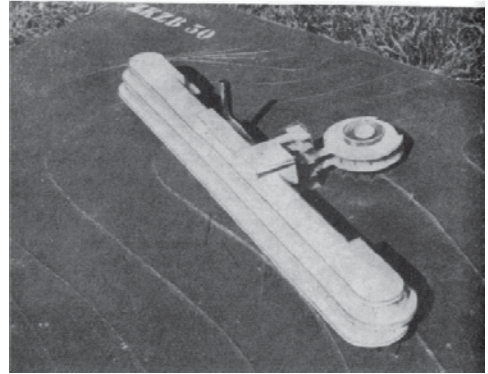

P13

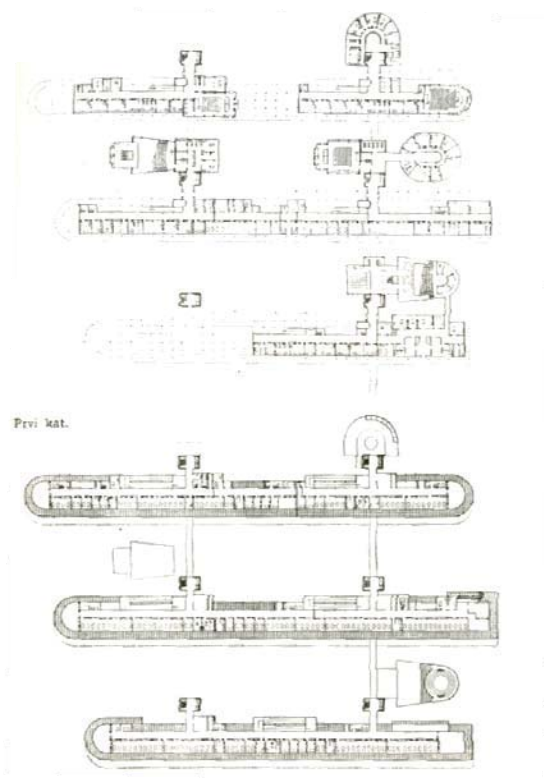

P14

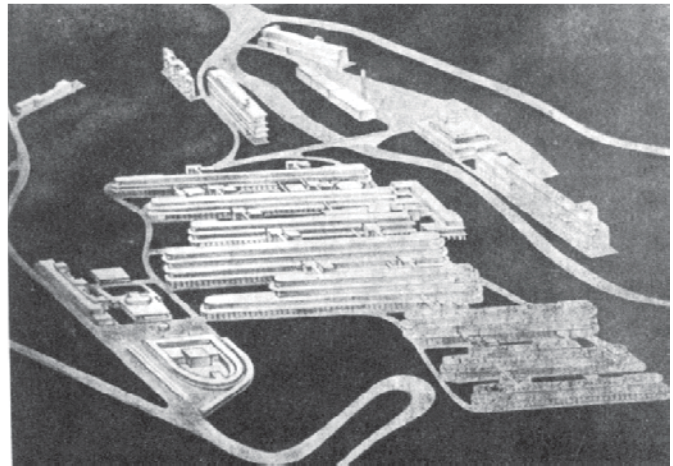

P15

FIG P12,13 - Competition entry by Ernest Weissmann for the hospital complex of Zagreb 1930-31, Awarded project 1 of 3 *ex aequo*. Source: (Fig 12) Planic, 1932 (ed.1996):34, (Fig 13) Planic, 1932 (ed.1996): 36)

FIG P14 - Plan of the competition entry by Ernest Weissmann for the hospital complex of Zagreb. Ground floor plan and first floor plan. Awarded project 1 of 3 *ex aequo* , source: Planic, 1932 (ed.1996): 33

FIG P15 – View of the complex on the hill, competition entry by Ernest Weissmann for the hospital complex of Zagreb. Ground floor plan and first floor plan. Awarded project 1 of 3 *ex aequo*, source: Planic, 1932 (ed.1996): 33. Important book for the Architecture of Modern Movement: *‘Problemi Savremene Arhitekture’*, 1932, (*‘Problems of the Contemporary Architecture’*), with published Declaration from La Sarraz, and some important articles and projects / several competition projects and realized projects of the Modern Movement during those years and some published from this international competition

General information about the participation and the results of the competition

The competition of the Hospital Complex of Zagreb was published in mid 1930 and dated January 15, 1931, where eighty entries were submitted for the competition from:

Germany,49; Czechoslovakia,11; Yugoslavia,5; Switzerland,5, Austria,2; Finland,2; Hungary,2; Poland,2; Albania,1; Roumania and Russia,1. Many participants of the competition were from Germany because this competition was published in many international journals, especially in German-speaking countries. The jury was formed among others by Walter Hanauer (Zurich), Dr. Wilhelm Kreis (Dresden) and Roger-Henri Expert (Paris).

In May of 1931, have published results without the first prize because the jury was opined that a majority of participant didn't think about the local limitations, they called "impossibles" many of presented projects, including the Aalto competition entry. *Three ex aequo awards were given to František Èermák and Gustav Paul (Prague), Bernard Stein and Richard Zorn (Hamburg) and Le Corbusier's associate Ernest Weissmann (Zagreb). Five purchased entries were made by Jadwiga Dobrzynska and Zygmunt Loboda (Warsaw), William Dunkel with his associate Heinz Lipp (Zurich), Benno Schachner (Munich), Gustav Schöler (Vienna) and Hans Tietmann and Karl Haake (Düsseldorf).*⁵

Aalto published in the review *Arkkitehti*⁶, next to his published description about his proposal, the photo of the model of the competition entry, one of the three *ex aequo* awards: Bernard Stein and Richard Zorn (Hamburg) (Fig P16a).

The program of the completion gave two main options for the general organization of the new hospital complex with clinics: 1.option, recommended, as the system of the individual pavilions of the clinics and hospital departments and the 2. option as a "monoblock", a new building system, more used in 1930's, the system with one/two buildings with the orientation east-west which applied some participants.

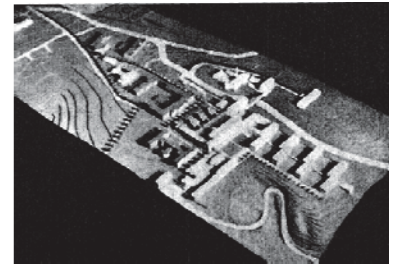

P16a

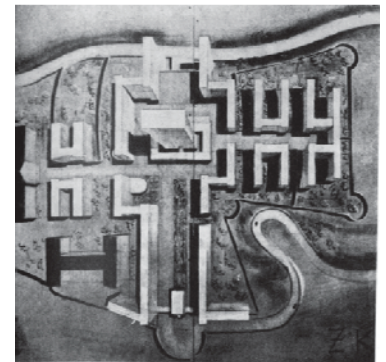

P16b



P16c

⁵ Bjazic T., 2012: 288 (in this article are published awarded competition entries)

⁶ *Arkkitehti* (XII), 1932:6

The possible reasons of Aalto's participation in this International Competition

By analyzing Alvar Aalto's biography we can deduce some reasons for his participation. Aalto this year of the competition, 1930, didn't have many projects realized in his office where he collaborated with Erik Briggmann in Turku (since 1927), and those years 1929-30 he participated in many unawarded competition projects and also, he was searching for the personal "own" language as the answer to the new modern movement. He already had a positive experience with his winner project of Paimio Sanatorium. However, Aalto still did not finish this project at the moment when he developed the ideas for the HCZ. There an interaction between these two projects is clearly observable (analyzed during this study in the last two parts, of the residential part of the hospital complex, residential building type I and II and the last part of the analysis of the Aalto's HCZ competition project with some interactions between the Zagreb Sanatorium and Paimio Sanatorium).

Since the congress CIAM in Frankfurt in 1929, Aalto has been the representative of Finland. From CIAM he had a strong relationship with Sigfried Giedion, who at the same time had a permanent contact with Le Corbusier and Weissmann who collaborated with him in the office in Paris. We can assume that this international competition, with many participants from the Germany and Switzerland, was well known to CIAM group, opening many doors to international ideas of the Modern Movement.

Aalto has preserved all his drawings together with all his early sketches and some photos of 3d-model. One year after this competition he was published in *Arkkitehti* an article about this competition entry, which shows us his satisfaction with the implemented ideas of this project.

Only few drawings of awarded participants of this HCZ international competition are preserved, and we can think that this Aalto's unawarded project, with all its preserved sketches in the Archive of Alvar Aalto until today, is now very important source and base for this analysis and understanding of all his later works and without all of them, this study could not be possible.

FIG P16a – one of the three *ex aequo* awards: Bernard Stein and Richard Zorn (Hamburg), Competition of the Zagreb hospital complex (1930-31), photo of model. Source: published in *Arkkitehti XII-1932*, next to the Aalto's description of his proposal. , p.5-6 **FIG P16b** – Proposal project by Stjepan Planic (Croatian architect), HCZ competition entry 1930-31, Source: Planic,1932, (ed.1996): 21 (graphic Tomasevic) **FIG P16c** - Proposal project by Zoran Strizic (Croatian architect),HCZ competition entry 1930-31, Source: Planic,1932 (ed.1996):27

Competition Program – general notes

- Some relevant parts of the competition program-⁷

The competition program was delivered together with the plans of the city (with also marked old "medical campus" of the Clinics of the University of Medicine, where only five buildings of the whole medical complex of the clinics were finished until the year of this competition). All participants had with the all documentation of the competition, plan of Zagreb in 1923 and the book-City guide: "*Zagreb Past and Present 1093-1930*"⁸, by Dr. Stjepan Srkulj, who was the Mayor at that time. This is important to understand a future reinterpretation of the existed formal elements of the old clinic buildings in the context of the competition and all future influences on the Aalto's competition entry.

The original program of the competition was published in two languages, in the native language, Serbo-Croatian and all foreign participants received the program in German (because the majority of the participants were from Germany (49) and Switzerland (5)). The program contains fifty pages and in this study will be only explained some parts of the text relevant to the whole complex and each area of the complex will be treated in the analyzed functional parts of the complex.

The participants of the competition needed to deliver a situation with all buildings of the General Hospital and Specialized Clinics: floor plans, relevant sections and elevations, facades (scale 1: 200), plan of the whole complex (scale of 1: 1000) with marked all routes between all objects or groups of the objects together with marked all connections with the city.

In the first part of the program are given descriptions of the main parts of the site and the new complex with the orientations and locations.

It was planned to build two main parts of the hospital complex next to each other, with the close connection between them.

⁷ The original program of this competition, with all conditions of the competition and all necessary spaces with the necessary areas and guidelines of the future projects of the competition from the source : AAA

⁸ Guide of the City of Zagreb (1930). source: City and University Library of Ljubljana, Slovenia

Planned capacity of the two hospital complex parts: Specialized clinics with 375 patient beds and the General Hospital with 620 patient beds .

Five specialized clinics in the North part and seven hospital clinics of the Foundation hospital in the South part of the complex.

The site of the competition contains three lots (Fig P17):

Lot 1 - Specialized Clinics of the University of Medicine needed to place in the northern part of the Lot 1., the Foundation Hospital (General) needed to locate in the southern part of this lot.

It is also planned the residential zone for medical staff.

- Lot 2 - located on the one hillside is optional gave the location for the Community Service Part of the Complex and the rooms for the staff and nurses (also the program has offered the other option to organize this Service part of the Complex in the main hospital complex part of the Lot 1).
- Lot 3 - is an isolated lot, one kilometer away from the Lot 1 (General Hospital and Specialized Clinics), reserved only for the one building of the Sanatorium of Tuberculosis.
- The entrance and reception building of the complex were previewed for the west of the complex
- It's detailed, that the site is located on the hill (40 m height), next to the center of the city in the northeastern part, where the northern and central part of the hill are quite flat and the southern part of the lot 1 is sloped hillside. Further is explained that this site of the new hospital complex is viewed from any point of the city and because that was necessary finding the best visual solution for the new complex , but priority is given to the function of the complex
- The Lot 1 and 2 are separated by the main road of the urban areas and there was a need to design the bridge to connect both areas, lot 1 and 2..

Also the program contains some of general geological data about the terrain and described the climatic conditions on the hill: *"very open field located on a hill above the city and frequently exposed to the severe weather conditions with strong winds and the rain in the summer from the southwest with the storms and winds*

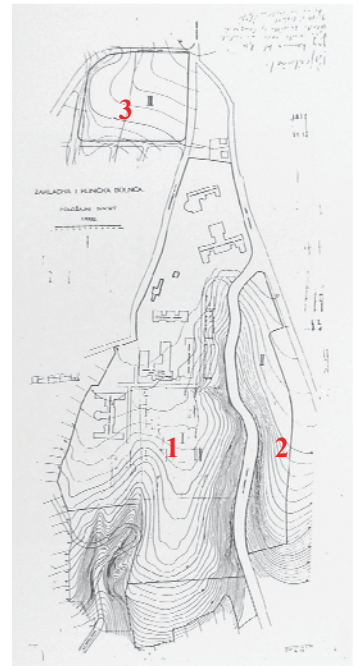

FIG P17 – Map of the site, 3 lots,
source: 50/609, AAA

of the northwest part and in winter with strong winds from the northeast part of the complex”.

The program gave some general information about the built context on the hill where is written that in the northern part of the Lot 1 existed some old buildings of the Clinics of the University of Medicine (the old complex found in 1917, but until 1930 just partially realized). These buildings are marked on the map of the site. (Fig P17)

All new buildings have to be planned as a two-story or three-story buildings, except the buildings that are located on the flat side of the hill. Surgery clinic and internal clinic is required with a possibility of the future extensions of space.

The program of the competition also gave the possibility to the general organization through individual or separate pavilions or through united clinic buildings in the one or two “monoblocks”⁹, in the case where is not adequate the other system of the individual pavilions .

Each clinic has very detailed program which gave the competition program and analyzed during this study in the context of each specific area of the complex.

⁹ “Monoblock” those years started to use as the popular building system which would be used in the future years. The Competition program gave the priority to the individual building system by separated pavilions, but also gave the option of the organization of the Hospital complex into the one “Monoblock” (one or two buildings) , and some participants of this competition e.g. Dunkel, Tietmann and Haake. were applied that system for the new hospital complex.

III AALTO'S COMPETITION ENTRY

“Edge effect” / Aalto’s Competition Entry: “Hospital City” on the hill

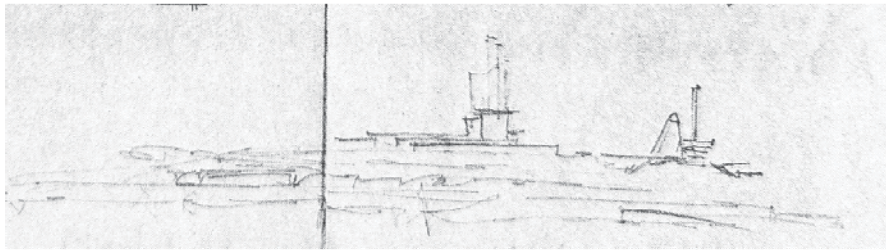

U1

Aalto and the Site as “Acropolis”

Aalto with his own words describes the natural context of the location of the new HCZ: “New Hospital complex is placed near the center of the city of Zagreb on the flat mountain as a kind of Acropolis of the city, elegant and surrounded by lush terraced vineyards, despite the difficult terrain it is a great location for the purpose”.¹

Aalto was very interested as a painter in Mediterranean cultures, especially in Italian culture where he made many sketches during his travels in Italy 1924. These sketches show us a great source of his inspiration found in the Italian landscapes with terraced hillsides and the small ancient cities. Aalto analyzed the paintings of various artists such as Andrea Montagna (visited Italian city Padua in 1924).

His Inspiration from Nature can be observed in almost all of his works inspired by the country landscape of Finland together with the “obsession” with images of the Mediterranean cities of an ancient culture of Italy and Greece.

This location of Zagreb, like terraced hillsides of Italy, was for him a perfect basis for the inspiration, as a laboratory for new ideas. This perfect location, where the new hospital complex was planned Aalto described like a “*crown of the hill*”;

¹ Aalto, *Arkkitehti*, XII, 1932, P 5-6



U2

FIG U1 – Aalto’s early sketch of the Competition of the Hospital complex of Zagreb, 1930-31, 50/635, AAA

FIG U2 –Panoramic view of the Zagreb, (the hill “Siroki Brijeg” and the center of the city) “Acropolis” of the city, source: Laslo,2004:120

“hospital city” as the “Acropolis”.² (Fig U1). The future hospital complex, planned on the hill with inclined slopes, enables a perfect insolation and air circulation, constituted a perfect location for the use as a therapeutic architecture in nature.

Some old photos of the city could be observed by participants from the book: “*Zagreb in the past and present 1093-1930*”; by the Mayor of Zagreb, Stjepan Srkulj, where are published in this city guide some photos of the city and short explications of the architecture of the city.³ Aalto observed and analyzed the local context from the plans of the city and the photo documentation. This local context (natural and built) would be one of the main inspirations for the creation of the new ideas for this Aalto’s competition entry⁴ (Fig U2)

In description written by Aalto about the site of the competition of the Zagreb hospital complex, he metaphorically called the Salata’s Hill: “*Acropolis*” and the “crown of the city”, and that description shows us his initial ideas and the future monumental character of the façade of the whole complex viewed from the city as the really one “Ancient city” on the hill, which become Aalto’s “religion”, where he said: “*Ancient city*” has become to mean to me something like a religion, illness or insanity. The city of hills, with its live, wavy lines, following an unexpected path, previously unknown to mathematicians, is for me the incarnation of the difference between the brutal mechanization of life - whose manifestation in the modern world is the prevailing ugliness - and religious beauty. I see it just the every day and the sublime time, the art, the way that modernity does not in any way create, but tries to avoid with all his might. (...). its aesthetic value emerged as an independent result of the whole process; Like the beautiful strokes, full of culture, Mantegna Fresco”.⁴⁻¹

² Ibid, p 5

³ View part of the Annex with the most relevant parts as the inspiration to creation of Aalto’s ideas of the city guide “*Zagreb in the past and Present 1093-1930*”, Stjepan Srkulj (Major of Zagreb), 1930, this information can find in the article of Laslo A., “Podijeljene Muistot”, Oris, 2004

⁴ Laslo A., “Podijeljene Muistot”, Oris, 2004

⁴⁻¹ Schildt Göran, Alvar Aalto in his own words, Otava Publishing Company, Ltd., Helsinki, 1991 (Ed. 1997). Traducción al español: “*Alvar Aalto de palabra y por escrito*”, El Croquis Editorial, Madrid, 2000, p.67-68



FIG U3– Plan of the city of Zagreb, (1923), scale 1:10000, 50-608a, AAA, (marked with the red rectangle the site of the competition and the old center of the city with yellow circle)

This map had all participants of the competition, and on other reversed side of this paper (with large size) , Aalto drew one synthesis of the all implemented new principles ideas on this project

Natural Urban planning / "Edge Effect" - Spatial theory

(Urban composition/Orientations/ Main routes)

During the analysis of the hospital complex composition on the hill can deduce that have all characteristics of the "natural urban planning".

Aalto, after his last journeys to Italy reflected about this Natural Urbanism: *"City on the hill has acquired, in another sense, a new value for me: it is the purest, original and Natural variant of Urbanism. And its natural beauty is the most beautiful thing a man can perceive at ground level. Man captures this vision as a harmonious whole and integrated, consistent with its own size and its sensory limits"*⁵

The site and the urban composition of the Aalto's competition entry can analyze through the Spatial Theories in Nature. We could understand the Site of the HCZ Competition as the correlation of the new buildings of the hospital complex with the existing built context of the old clinics on the "border" - hill, site of the competition observed with the "Edge effect", phenomenon between the ecosystems on the "border" (as between two contexts). In nature between two natural ecosystems occur a phenomenon of the penetration of the one context to other, called "Ecotone"⁶.

It is observed at the same time Edge effect with a more intensified "biodiversity" and the density of the species. As the diversity of the "species" in nature, it is possible to metaphorically understand these "species" as new ideas and principles that born between the different contexts on the hill: old medical complex, next to the city center, and the road with the other complex part on the other hillside. *"The tendency for increased variety and density at community junctions is known as the edge effect. It is common knowledge that the density of songbirds is greater on estates, campuses and similar settings...as compared with tracts of uniform forest."*⁷

⁵ Journey to Italy Casabella Continuita no 2000, 1954 (published in Schildt, "A. Aalto de palabra y por escrito", El Croquis Editorial, 2000, p.58 (translation, spanish version)
⁶ Graves, R. (2011). *Ecotone*. Retrieved from <http://www.eoearth.org/view/article/152345>. The concept of an ecotone can be traced back to the work of Livingston (1903) and Clements (1905) ⁷ Odum Howard, 1953:p. 278

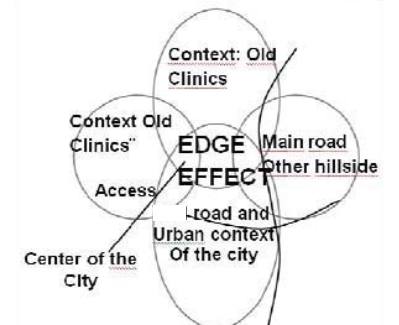

FIG U4 – Panoramic photo of Zagreb with the Hill next to the old city center, "edge effect" between the different contexts. (Laslo2004:120)

FIG U5 –Photo from the site of the competition of Zagreb between two hillside, between zone III and IV, "edge effect", "arch-diversity" on the border (comparing with the biodiversity)

FIG U6 –Scheme of the site on the hill with many influences from different context.

Natural limits – hillsides and valleys where it is observed intensive diversifications and where are born elements of the Aalto's architecture language



U7a

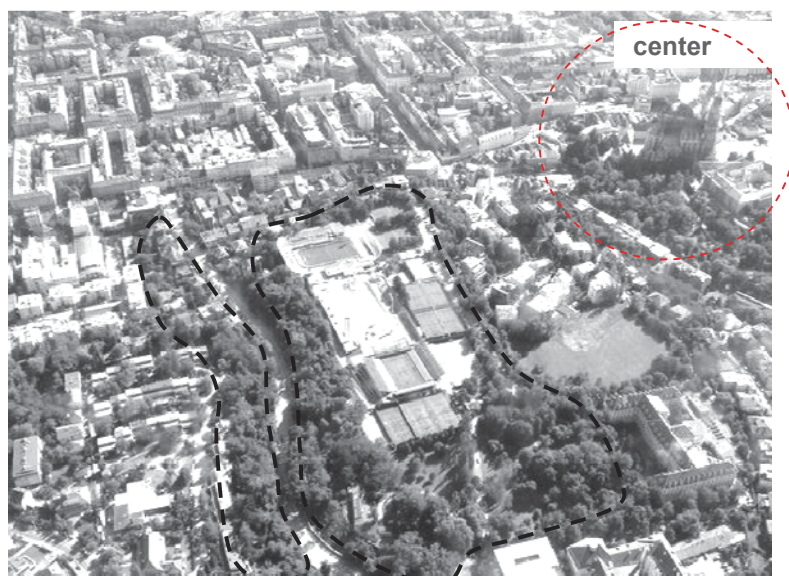

U7b



U8

FIG U7a,b –view of the site of the competition, hill “Siroki Brijeg”, relation with the city (visited 10.3.2012), where we can see the zone and compare with the “Edge Effect” and “Ecotone” from the Spatial theory of the processes in Nature, and can understand the multiplication of the same species and biodiversity as arch-diversity on the site next to the limits. source:Google Earth

FIG U8 –Photo from the site of the competition of Zagreb between two contexts, “edge effect”, “arch-diversity” on the border (comparing with the biodiversity), view of the old city center – towers of the cathedral from the site on the hill (position of the north Clinics)

Edge effect is observed between two natural spaces, where also humans affecting and cut, forming the edge effect where sun penetrate more, and more intensive on the hill, and there, new ideas of the urban composition were born on the one perfect base. (Fig U5-9) In this zone of the Ecosystems of Nature we always find the strong diversity of the species, in biology: "biodiversity", in architecture could be: "arch-diversity", as diversity of the new principles of the Aalto's project on the hill analyzed in this study.

"Spatial autocorrelation refers to the value of the samples taken close to each other and are more likely to have a similar magnitude than by chance alone."⁸ When a pair of values located at a certain distance apart is more similar than expected by chance, the spatial autocorrelation is said to be positive. Tobler's first law of geography explained: "everything is related to everything else, but nearby objects are more related than distant objects"⁹

It is maybe possible to used the laws from nature from these spatial theories to better understand the relation of the Aalto's new hospital complex within the natural and built context, especially in respect to the natural configuration of the ground, the limits of the lots and the relation with the old buildings between the two different contexts and the city.

Christian Norberg Shulz, influenced by the philosophy of Martin Heidegger, treats two main characteristics which contain the place: 1. "space" - three dimensional organization and 2. "character" - atmosphere of the place, the spirit, sense of place which Norberg Shulz calls *Genius Loci*. Built environment contains: centre, path and domain. Norberg Shulz, to explain between the "local" and "general" takes the case of the main building of the University complex of Otaniemi (1949-1964) where Aalto was transformed the general openness of modern space into complex organism. This project from Zagreb influenced the project of the main building complex in Otaniemi, as the spatial organism and "backbone" with all similar elements.

⁸ Fortin, Marie-Josée; Mark R. T. Dale, *Spatial Analysis: A Guide for Ecologists*. Cambridge University Press.2005

⁹ Tobler W., (1970) "A computer movie simulating urban growth in the Detroit region". *Economic Geography*, 46(2): 234-240

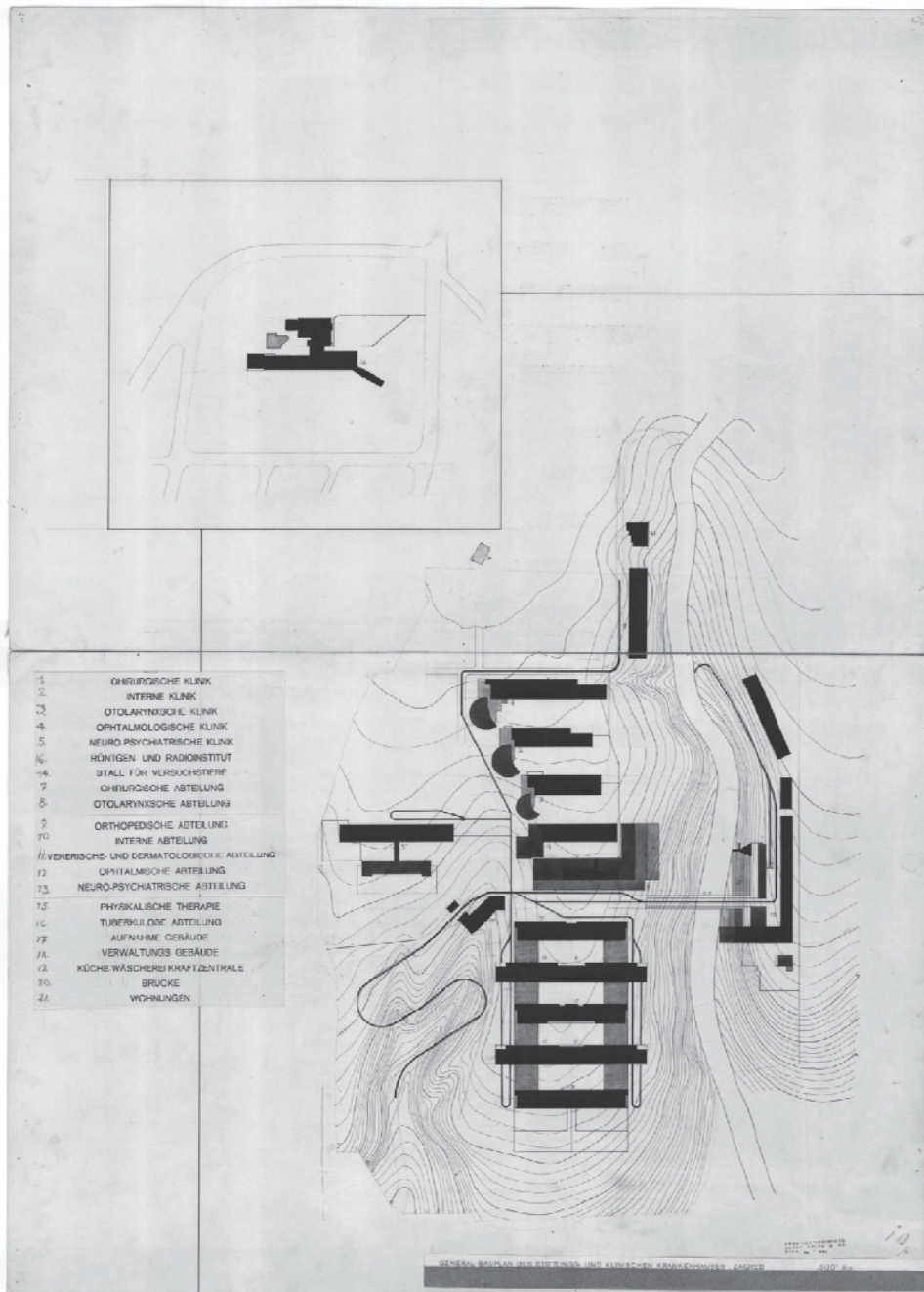

FIG U9 - Urban composition, competition entry for the hospital complex of Zagreb, (1930/31) "SUD- SOUTH", Aalto, source: 50/610, AAA

Urban planning on the site: General information

Aalto described his urban composition concept of the Hospital complex (Arkkitehti, 1932): *"The Urban composition of a complex is based on the individual buildings system with orthogonal geometry and a rectangular shape whereas, its base is connected to a functioning network of external and internal routes and exterior gardens as the interior-exterior spaces between buildings"*.¹⁰

For the extensive program of the hospital complex with different zones, Aalto planned more than 20 pavilions on the two main lots of the complex (Lot 1 and 2) (Fig P16). In Lot 1 on the north, he previewed the Specialized Clinics of the University of Medicine and in the southern part the General Hospital (Foundation Hospital). In the northern part he also planned residential and administrative area. Service part of the complex, with the rooms for the nurses on the highest floor, he planned in lot 2. Sanatorium building was planned on the isolated lot 3, one kilometre away from the lot 1 of the hospital complex. The competition program gave the two options of the possible urban plan: system of the individual pavilions of the hospital buildings and other optional system of *monoblock*, as the new mega-structure which was an advanced technique of these years.

Aalto applied the first system of the individual pavilions, to create the smaller individual units as the "individualism" inside the "collectivism", which was Aalto's theory from the beginning of his trajectory.

Description of the Aalto's proposal, delivered with the project of the competition, written by Aalto:

"Principles of Urban Planning:

- 1. Physiological and Psychological well-being of the patients. Concerning the Light; Air and Environment*
- 2. Internal functions and location of the technical rooms*

¹⁰Aalto published this competition entry, project with descriptions and photos on two pages in Arkkitehti 1932/ XII

3. *External functions and connections with the pavilions (tunnel)*

4. *The possibility of the pavilion extension*

Orientation

“All patient room windows are oriented directly toward the South. This orientation was necessary without fail by the author, but as the part of the competition program and due to physiological weaknesses.

With the orientation of all windows in the same direction the building construction based on the scientific standards of a window system is easier.

The system has to fulfil expectations of the technical and psychological aspects of the hospital, for example:

1. *An entrance of daylight the most favourable possible to reach the depths of the room.*

2. *Good window ventilation.*

3. *Ability to make shadow by interior shutters.*

4. *Ability to protect the interior temperature by the exterior waterproof fabrics¹¹*

It is possible to conclude, from this description of the proposal, that Aalto wanted to create one modern complex applying the new technologies and standardization, respected the main technological ideas of Functionalism, but the first and most important is the first principles he wrote: ***Physiological and Psychological well-being of the patients.***

Influences from the natural configuration of the site on the hill

The image of the entire complex from Aalto's proposal is possible to understand in the one "organic" way as a "spine" of the human body, influenced by the configuration of the terrain (flat part on the hill between the hillsides), the stretch and enlarged form of the lot. The hospital complex is composed of two main parts and six zones with two main axes North-South and East-West, creating the view from the city center as a monumental façade of the complex (as Acropolis).

¹¹Aalto delivered together with the all final drawings of the competition entry for the hospital complex one short description of the project (added in the annex part of the thesis, original language of that text - german). Source:AAA

However, at the same time Aalto formed the contemporary composition implementing the standardization of the construction. These two systems of the north and the south of the hospital complex, with clear rules of the orthogonal plan, created a visually symmetrical form as the "backbone" on both sides of the main horizontal path of the whole composition (W-E), following the topography of the hilly terrain (N-S). The main horizontal path runs from the entrance of the complex in the West by the underground path – tunnel across the bridge, connecting the two blocks of the hospital complex of the North and South (Clinics with the School of Medicine (N) and General Hospital (S)), with the community service area, located in the East at the same height of the flat part of the hill with the hospital complex, All details are analyzed in the next chapters of each of the six main zones.

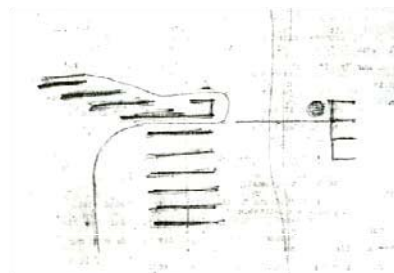

FIG U10

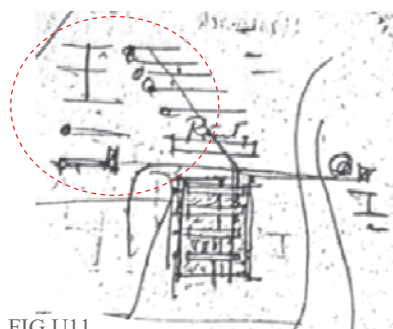

FIG U11

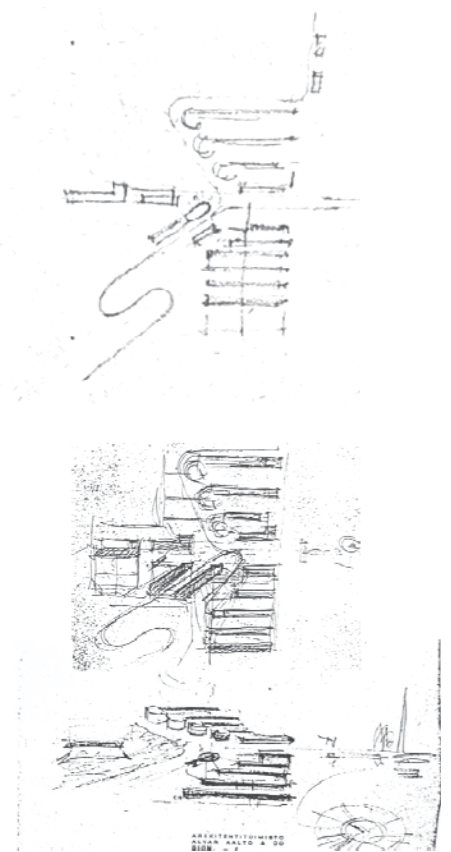

FIG U12 a,b,c

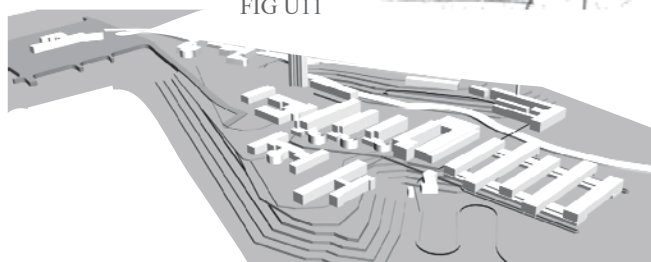

FIG U13

FIG U10 – Scheme of the urban composition of the whole complex based on the orthogonal system of the parallel pavilions following the configuration of the terrain and the stretch and elongated lot on the hill, source: AAA

FIG U11- In other scheme Aalto includes with the same composition old exist building of the Clinic of the University of Medicine. Final version, is orthogonal option of the General Hospital complex of the south, for the functional reasons and for the best circulation in the whole complex (free of the traffic, formation of the tunnels as the base, with different separately corridors for different uses) , source: AAA

FIG U12a,b,c – Early sketches of the composition of the whole hospital complex, In some sketches Aalto developed the idea of the central composition as "Agora", more classical composition on the hill which Aalto called "Acropolis" and where he wanted to give the monumental aspect of the whole complex.source: AAA

FIG U13 – 3d conceptual model of the composition of the Aalto's competition entry

Zoning

- I CLINICS
- II FOUNDATION HOSPITAL (7 CLINIC DEPARTMENTS)
- III CENTER OF RADIOLOGY AND PHYSIOTHERAPY
- IV COMMUNITY SERVICE OF THE COMPLEX
- V RESIDENTIAL AND ADMINISTRATIVE AREAS
- VI SANATORIUM

- | | |
|----|--|
| 1 | SURGERY CLINIC |
| 2 | INTERNAL MEDICINE CLINIC |
| 3 | OTORHINOLARYNGOLOGY CLINIC |
| 4 | OPHTHALMOLOGY CLINIC |
| 5 | NEUROPSYCHIATRIC CLINIC |
| 6 | CENTER OF RADIOLOGY |
| 7 | HOSPITAL SURGERY DEPARTMENT |
| 8 | HOSPITAL OTORHINOLARYNOGOGLOGY DEPARTMENT |
| 9 | HOSPITAL ORTHOPEDICS DEPARTMENT |
| 10 | HOSPITAL INTERNAL DEPARTMENT |
| 11 | HOSPITAL DEPARTMENT OF DERMATOVENEROLOGY |
| 12 | HOSPITAL DEPARTMENT OF OPTHALMOLOGY |
| 13 | HOSPITAL NEUROPSYCHIATRIC DEPARTMENT |
| 14 | EXPERIMENTATIONS WITH ANIMALS |
| 15 | PHISIO THERAPY |
| 16 | SANATORIUM |
| 17 | ENTRANCE BUILDING (RECEPTION) |
| 18 | ADMINISTRATION AND RESIDENTIAL BUILDING (Ib) |
| 19 | SERVICE CENTER OF THE COMPLEX: KITCHEN , LAUNDRY, HEAT PLANT,SILO... |
| 20 | BRIDGE |
| 21 | RESIDENTIAL BUILDING- TOWER |
| 22 | RESIDENTIAL BUILDING-staff (not medics) - (Ib) |

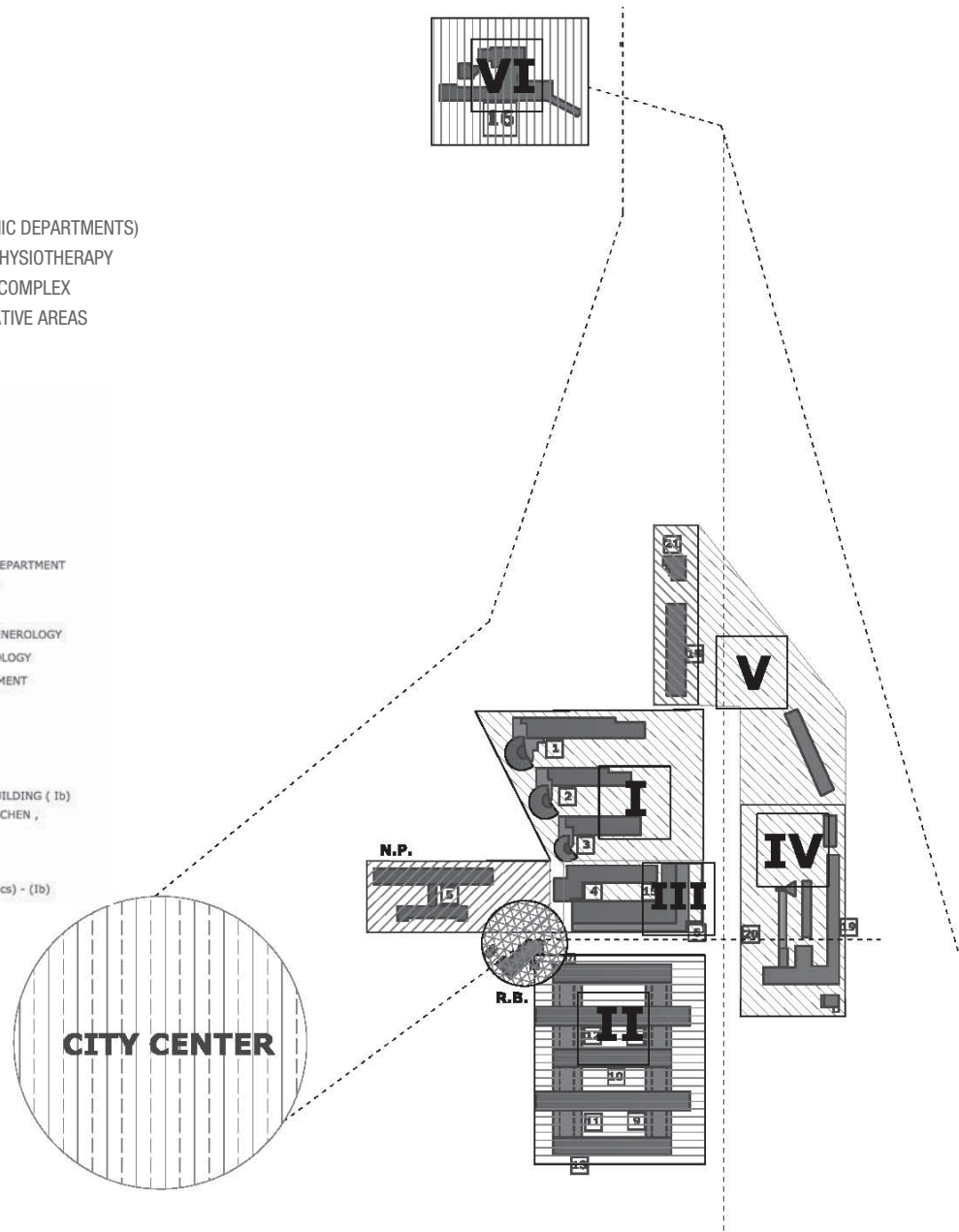

FIG U14 – Scheme of the main functional areas of the complex- Zoning

By analyzing the plan of the hospital complex buildings can be define six main functional zones placed on the three lots of the site .

Main zones of the hospital complex:

6 main zones of the complex: 1.Specialized Clinics of the University of Medicine, 2. General Hospital (Foundation Hospital) , 3.Center of Radiology and Physiotherapy, (Lot I) 4.Community Service of the Complex (with rooms for nurses and service staff and the chapel) (lot II), 5.Residential and Administrative area (two principle types of residential buildings I and II), 6. Building of Sanatorium (lot III)

Orientation, insolation, wind protection on the hill

This urban plan Aalto chose based on the parallel pavilions for the functional needs of the hospital complex and the best insolation, also required in the competition program. South orientation was the main idea for the organization of the individual pavilions and also, because that Aalto named his competition entry "SUD"- "South". An important condition for the Aalto's composition of the complex was also the protection of the buildings from the strong winds on the hill. These conditions contain the program of the competition where was necessary the wind protection from S-W, N-W and N-E. The creation of this urban composition, also has the origin in the dialectical concept of the integration into the landscape, ground configuration and the integration with the existing references of the built context of the place. As in the nature, the main character of the Aalto's "Natural Urbanism" has the semantic logic of the laws of nature and the orientation of the vegetation which is substantial due to orientation towards the sun, towards the "life". The main characteristic of the Aalto's urban compositions is the orientation toward the sun, which is also created at the same time different compositions and forms depending on the functions comparable with the varying vegetation patterns in Nature.

Influence from the built context

The order of the new clinics follows the continuity of the position of the existing building, where together form a unique façade of the complex on the hill as the "Acropolis" above the city center. During the analysis is confirmed that existing buildings of the old medical campus will be also influenced the urban planning, composition and architectural language, where only four buildings were finished until the date of this competition. Many influences are visible on the main ideas of the urban composition and architectural language and principles which Aalto implemented in the design of the buildings of the each functional zone, each one with own "identity". It's not required in the program, but Aalto also respected the order of the new clinics following the continuity of the position of the existing building, where together with the context will form a unique façade of the complex on the hill which he called "Acropolis" above the city center. *(All details of the urban compositions of each part of the complex are analyzed in the next chapters)*

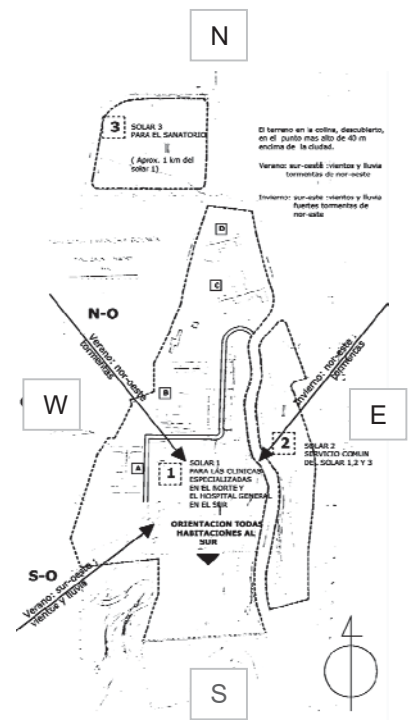

FIG U15 – scheme on the map of the site: climatic conditions. Necessary wind protection on the site : S-W,N-W,N-E. Important to understand "rotation" of the some previous orthogonal elements and to understand whole composition and new ideas as new principles of his architectural language but as the part also of the "Natural Urbanism", together with the program and other contexts

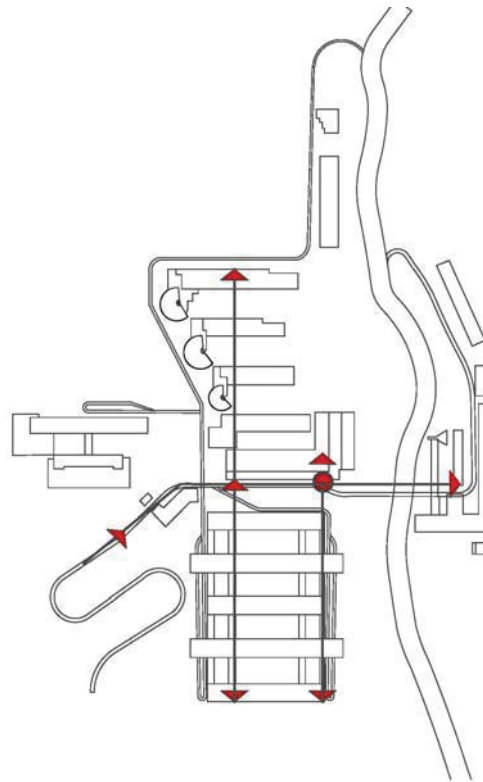
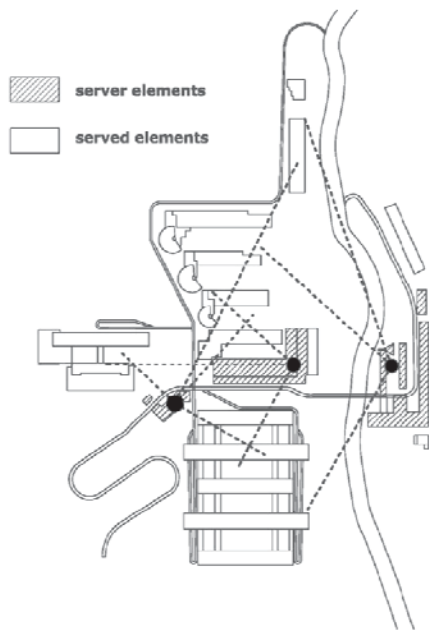
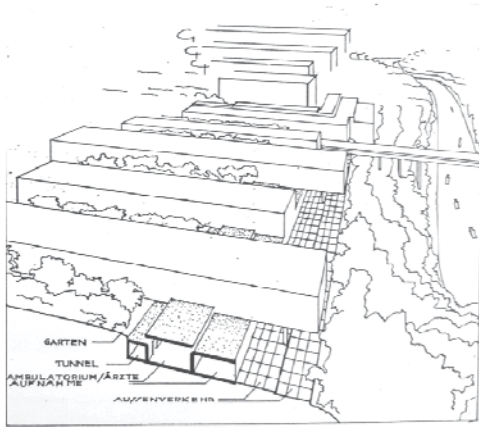

FIG U16 – Axonometric drawing of the southern complex of the Foundation Hospital General hospital with seven rectangular pavilions of the clinics on the base -supports of the two main corridors – tunnels which across the whole general hospital complex and 1 tunnel to the northern zone of the clinics and the School of Medicine and other on the W to the Service Community center (and nurse rooms) of the Aalto's competition entry for the Hospital Complex of Zagreb(1930), AAA .

FIG U17a – Scheme of the Aalto's proposal server and served elements of the complex

FIG U17b – Scheme of the main routes on the ground level and "black lines with red pointers" underground main paths - tunnels

Main routes of the hospital complex

Aalto explains in one short publication about this competition and his original urban planning system implemented, based on separations of the different types of traffic, pedestrian routes and service routes of the hospital complex.¹² For the first time, here he used the semi-underground routes through the tunnels with natural light separated for different uses. In this way he suppresses any noise or conflicts outside as everything "happens" underground, and also this system is more effective and functional because allows more shorter connections between different areas with lifts for the different users: employees, patients, customers and employees of the service of the complex. The cars also have their underground, separated roads.

The analog system of the separations of the underground routes with daily light Aalto applied, after twenty years again, in 1950, in the competition entry for the Kivela hospital complex¹³, also unrealized competition entry. Main routes he has adapted to the specific conditions of each part of the hospital complex with the educational functions of the University of Medicine, residential area, administration, and service area. In this way, he avoided any inconvenience between the different needs and functions of the complex.

The main routes through the hospital complex are West-East and North-South routes. They lead from the main entrance on the West to the final point of East, across the bridge-tunnel where Aalto placed services buildings on the other hillside. In the south of the complex is located General Hospital and in the North part are planned four Specialized Clinics and Lecture Halls with necessary spaces of the University of Medicine. In the North-west part of the complex Residential and Administrative area are located. Neuropsychiatric clinic is located on the West, next to the main entrance of the complex. At the complex central point, where both main path crosses: N-S and W-E of the complex, are located the central buildings of Radiology, Radiography, and Physiotherapy.

¹² We can find in the text descriptions of his project of competition and new ideas, written by Aalto and published in *Arkkitehti* 1932 (XII)

¹³ Unawarded competition entry

Main network of the circulation in the complex, it could be compared with the circulatory system with the "bio - characteristic" of the urban plan as the human body and a backbone connecting all main parts of the "body" of the whole complex. Connecting this routes of the complex with the Spatial theory from Nature: routes that form spontaneously, as in the nature paths are paved by the footsteps of the people or animals, yield the best logical connections between the spaces. By analyzing the main routes of the Aalto's new hospital complex, it is observed that he created the logic, "spontaneous" main paths of the complex following the configuration of the hilly terrain to shorten the circulations way and also he created direct underground tunnels as the shortest and most direct way to connect all functional areas of the complex.

In this study will be analyzed the main characteristics of the complex parts, important for the study of the creation of the New Principles of Aalto's architectural language and their possible origins and meanings. All details of the functions of the interior spaces of the hospital complex buildings are respected from the program and also it can be read in the final plans of the each building of the Aalto's competition entry (18 final drawings).

Each zone of the composition is analyzed in the next chapters

Aalto's article about his proposal

"In 1930 the City of Zagreb and The Croatian University of Medicine announced a competition for a great Hospital complex located in the Center on a plateau mountain, like some sort of Acropolis, elegant and surrounded by exuberant terraces and vineyards and despite the difficulties of the terrain it was a perfect location for its planned usage. In that mountain there are already existing buildings from the old hospital complex (Clinics and the University of Medicine), but the biggest part of the complex was in the planification stage. The Competition required that this projected part won't be changed and that it was a less important detail. In the background of the hill one can find the valley of 28m of depth, where the main road connects the different urban zones of the city. The Hospital Complex of "Hospital City" was located on a very inclined alley. Hospital complex in my project is planned in two parts; the north part with the university clinics and lecture halls, of the base in the form of $\frac{3}{4}$ circle. In the south of the complex the General hospital was planned as a unique and continued complex. Among them a connected building of the Radiology center. In the same way, administrative center were assigned with forty homes for doctors at an isolated terrain in the north of the complex.

Main Characteristics

Paths: Each part of the hospital had one direct external path, that can take anywhere without affecting the zone located in front of the patients.

The city and the hospital complex with its diverse parts unites an internal path with the daylight. The tunnel leads from the reception building of the complex, which is located in the lower cascades of the hill, the tunnel runs over the valley (connecting the other side of the valley from the service of the complex), and is built in a way that the internal traffic (access to each department of the hospital) is meant to be used only one time in the horizontal tunnel and after to use a lift. All the laundry elevators and services of the complex join with the tunnel. The delivery of this load is done by the elevators in the tunnel. Equipment cleaning area, kitchen, clothing area, everything is placed on the same level of the tunnel.

Buildings: Each department of the hospital is oriented so that all the patient rooms are placed towards the south, next to a quiet garden (among all its departments). The general scheme is made of two successive constructive systems of the building; Lower level of the general hospital in the north-south direction, including the clinics, surgical and medical, as well as the common spaces for all the different departments. The top floors have an East-West direction with the patient areas. One of the consequences of this traversal position "between the lower plant and the top floors" (using the convexity of the terrain) is that the gardens, separate the top floors from the hospital departments, are performed on the ceiling of lower plant and they join in closed areas (private areas). Conflicts between different types of circulation (exterior and the internal circulation of the tunnel) are not produced despite that at the same moment the exterior path of the tunnel is found on the same level and (these internal parts) runs in parallel direction leading to the hall and the elevator.

This system only affects one part of the north corner of the Clinic University. The windows, which are extended above the ceiling and applied the constructive system is of 3-4m. The emergency assistance rooms are located in the north, separated by the mobile glass partitions from the hallway. Using this system some of the patient rooms could be made deeper. The clinical universities from the north complex are three-story buildings. All the administrative, laboratories, ambulances and similar spaces are located on the lower floor, at the upper floor are planned the hospital space, operation rooms are placed next to the lecture halls of the University of medicine. The clinics need small operation rooms that are not planned on the lower level, and that are placed directly next to the hallway, where they are most needed and where it is expected. (operation rooms as the console of the façade)

Thus, even located among on the upper floors the ceiling light is designed and the frequency of use of these areas does not affect the ceiling of the patient rooms located below these rooms. So the negative impact of internal department systems is

also avoided. (The picture shows the clinical part of trachoma (ophthalmology clinic).

Separated from the complex, at a distance of 1 km, is located the tuberculosis sanatorium project.

The kitchen, laundry and storage of raw materials have been designed according to the rules of industrial circulation.

Lecture classrooms of the University of Medicine are planned along with specialized clinics:

Surgery

Internal Clinic

Otolaryngology

Ophthalmology

Neuropsychiatry

The General Hospital includes the following departments:

Surgery, ENT, Orthopedics, Department of Internal Medicine, Department of Dermatology, Ophthalmology, Neuropsychiatry¹⁴

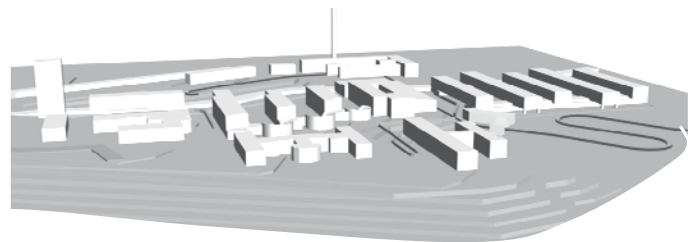
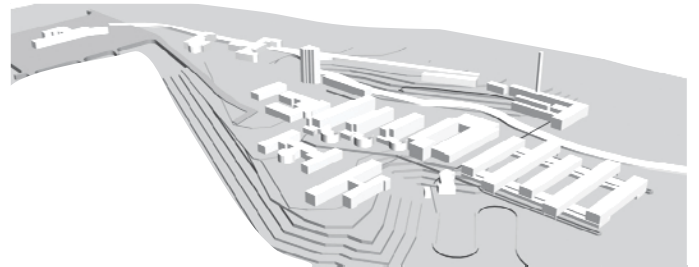
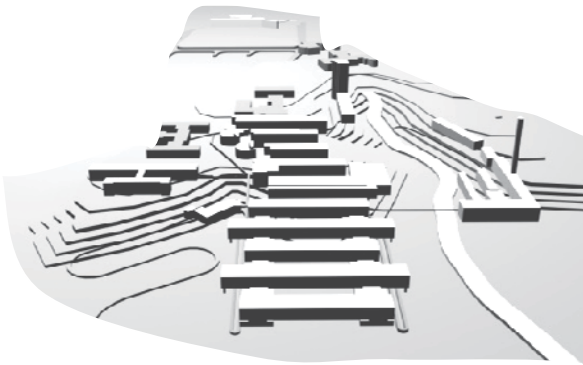

FIG U18c,d,e

¹⁴ published in *Arkkitehti XII/ 1932*, p.5-6

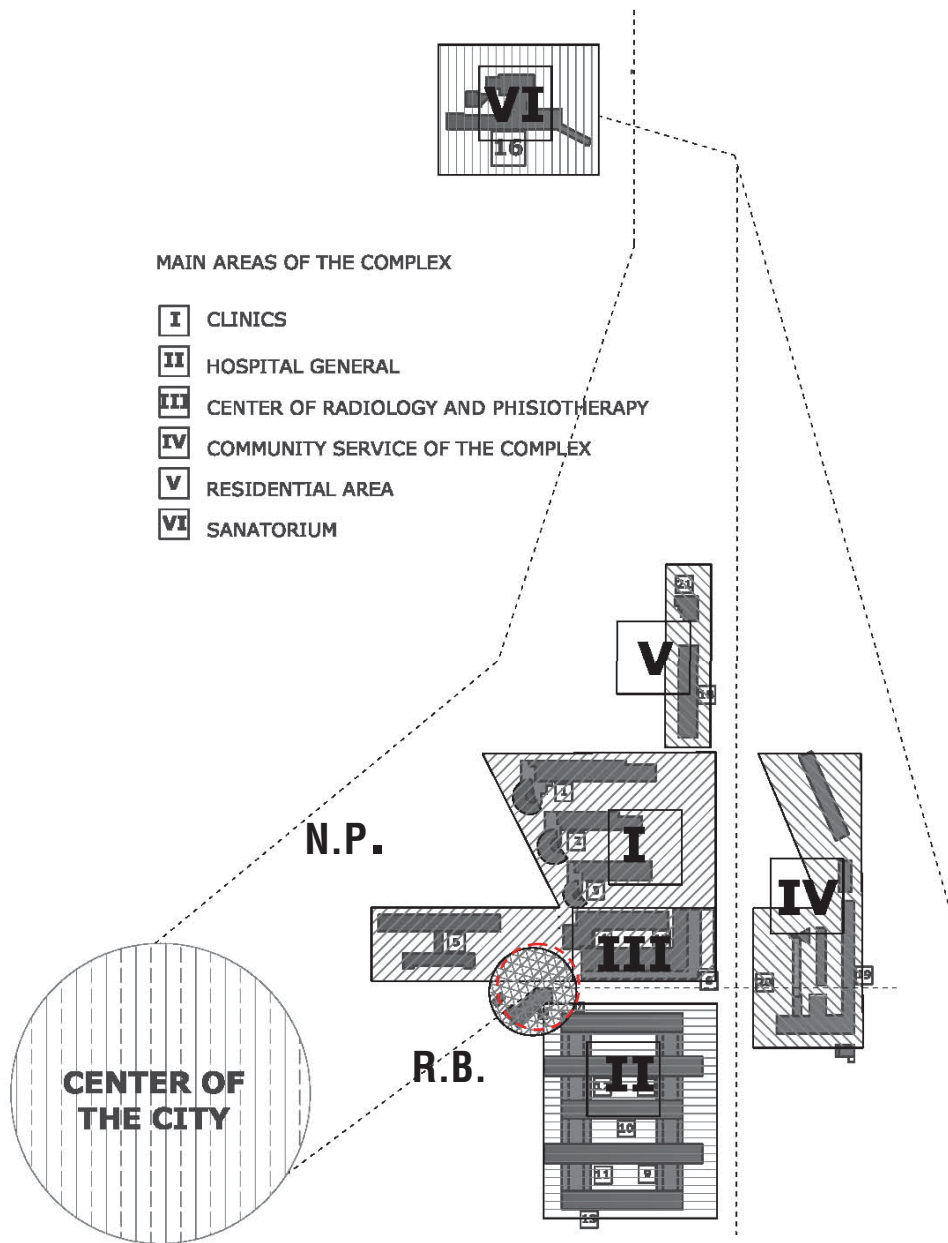
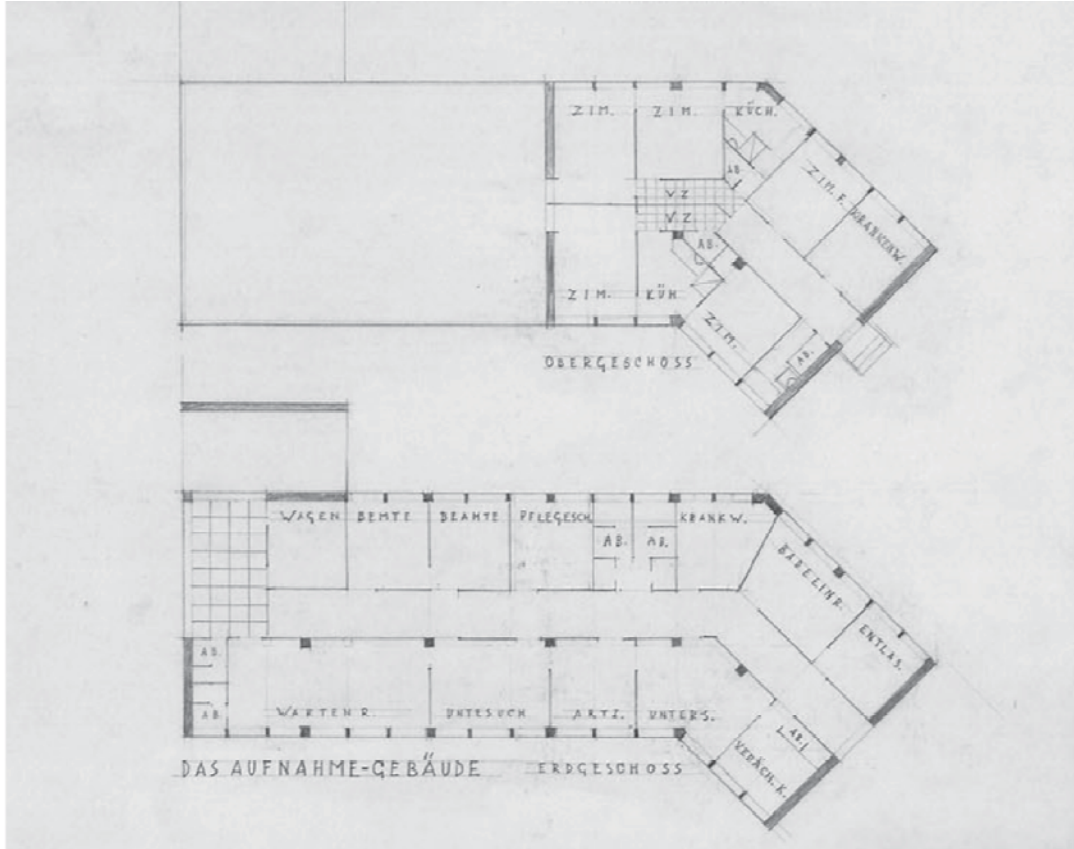
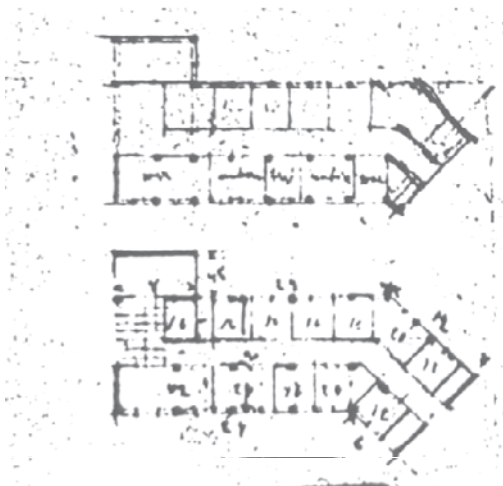

FIG C.1- Composition plan of the whole hospital complex Zagreb, Aalto, 1930/31 (marked the reception building (circle shape, no.1) and Neuropsychiatric clinic (rectangular shape, no.2)



E1



E1a

FIG E1 – Floor plans (ground floor and first floor) of the Reception building, (Ground floor contains waiting room, spaces for the patients, nurses and the main hall converted to tunnel – main routes of the whole complex, on the first floor there are two apartments of the keepers of the Hospital complex and his family) 50/627, AAA

FIG E1a – Early sketches 50/566, AAA

FIG E1b - Early sketches 50/551, AAA

FIG E2 - Scheme of the access to the Reception building (Access for the motor traffic and next that access entrance to the building) Composition plan of the whole hospital complex Zagreb, Aalto, 1930/31 (marked the reception building (circle shape) and Neuropsychiatric clinic (rectangular shape))

Reception building of the hospital complex (R.B)

Reception building is located on the West side, as the main entrance of the hospital complex, (Fig U19) is placed on the lower ground level on the hill and it is taking advantage of this terrain character. Therefore, Aalto created the main access to this building on the ground level with the main hall, which coming out of the building forms into the tunnel – main route of the whole complex, where he organized all traffic of the complex, separated for all users: motor traffic, employees of the service, patients and medical staff, visitors and others. (Fig E1,E2) This building has approached to the main road, connecting the city with the hospital complex. The closed driveway is located next to the entrance of the building and the form of the building follows the function of this building, placed next to the main routes of the complex to make easier operation of the entrance building. The ground floor contains the waiting room, spaces for the patients, nurses and reception spaces. On the first floor are situated two apartments for the keeper's family of the Hospital complex. This is a typical building of functionalism where Aalto adapted the form to the best function. This building and the next Neuropsychiatric are placed separately from the main part of the complex (Zone 1-6) as the entrance part of the complex and introduction for this study.

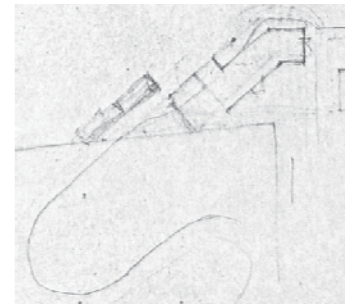

E1b

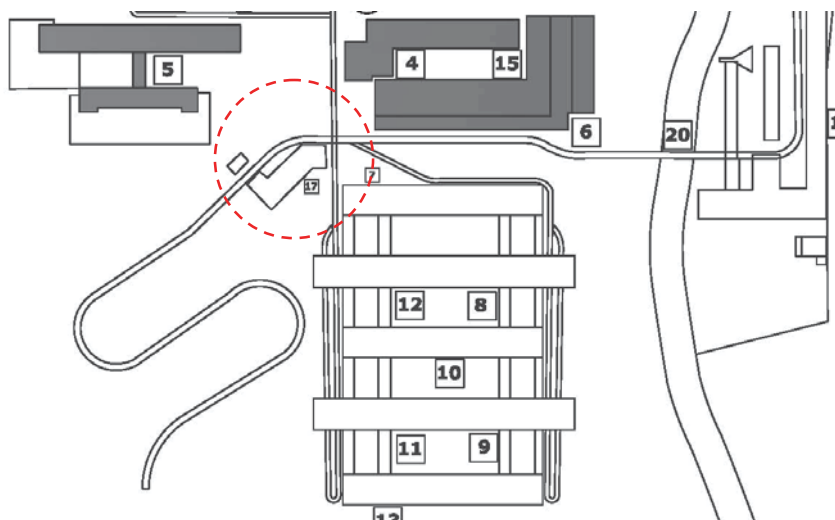

E2

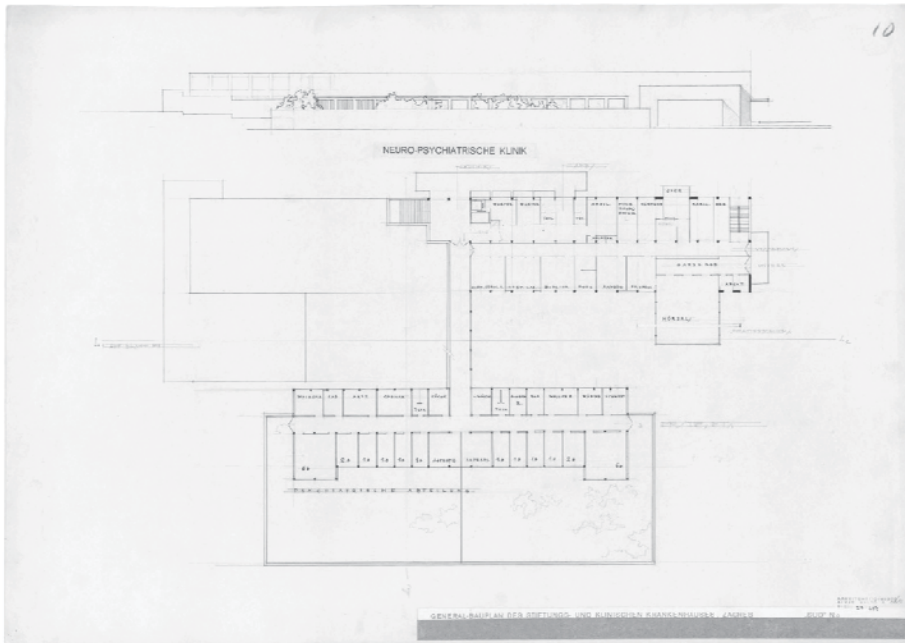

N1

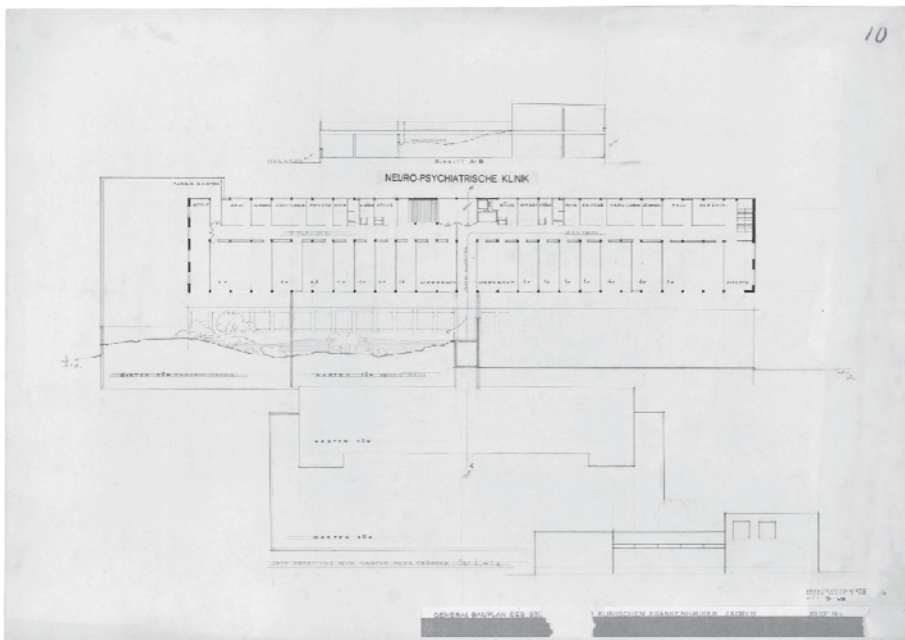

N2

The Neuropsychiatric Clinic (N.P.)

The Neuropsychiatric Clinic is located on the West side next to the main Entrance of the complex with the independent entrance, separated from the other part of the Hospital complex and placed closer to the city. (Fig N1-N3))

The competition program gave some design guidelines and required to place this Clinic on the border of the hospital complex, where it would not be interfered. For each clinical group (for the neurological and psychiatric part, separated male and female patients) the program required to design the four courtyards with high walls.

This clinic has the capacity of the seventy patient beds (46 of the neurological part and 23 of the psychiatric part). Aalto created the composition made by two main parts of the building, on the different levels of the terrain (Fig N4). On the upper level of the terrain he placed the two-story rectangular building with the ground floor with common areas of both parts (neurological and psychiatric part) and with patient rooms situated on the upper floors(separated female and male rooms), each one with the access to the courtyard-terraces. On the lower level of the ground Aalto located other part of the composition, as a rectangular smaller, one-story building with the psychiatric patient rooms and their courtyards. (separated female and male patients).

On the ground floor Aalto located all clinic spaces, outpatient units, laboratories and necessary spaces of the University of Medicine and the lecture hall for fifty students with the independent entrance. The composition of the building with the two main rectangular "bodies" connects the one central closed hallway between the parts is a similar floor concept of the Paimio Sanatorium (1929-33) and Kinkomaa Sanatorium (1927). The section with the characteristic window system above the ceilings of the patient rooms is implemented here enabling the "extension" of the light access in the patient rooms. (Fig N3) (which will be analyzed in the chapter of the New daylight system)

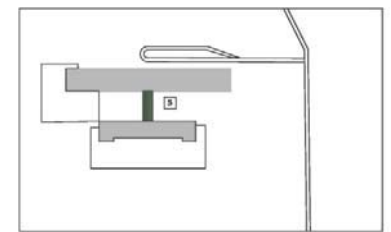
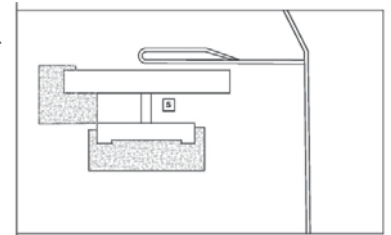

N3a,b

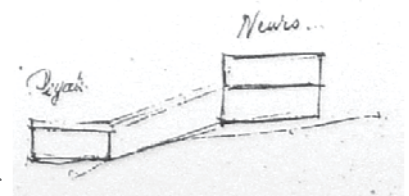

N4

FIG N1 - Neuropsychiatric clinic, ground floor, 50/619, AAA

FIG N2– Neuropsychiatric clinic, first floor, 50/618, AAA,

FIG N3a- Scheme of the ground floor with courtyards

FIG N3b– Scheme of the first floor with the bridge-tunnel – hallway and terraces- courtyards on the roof of the one-story building of psychiatric clinic.

FIG N4-Sketch of the Section, Psychiatric one-story building on lower level and Neurological two-story building on the highest level, all connected with inclined tunnel which ceiling is access to the from the Neuro patient rooms to courtyards on the roof of the lower level., source: segment, AAA

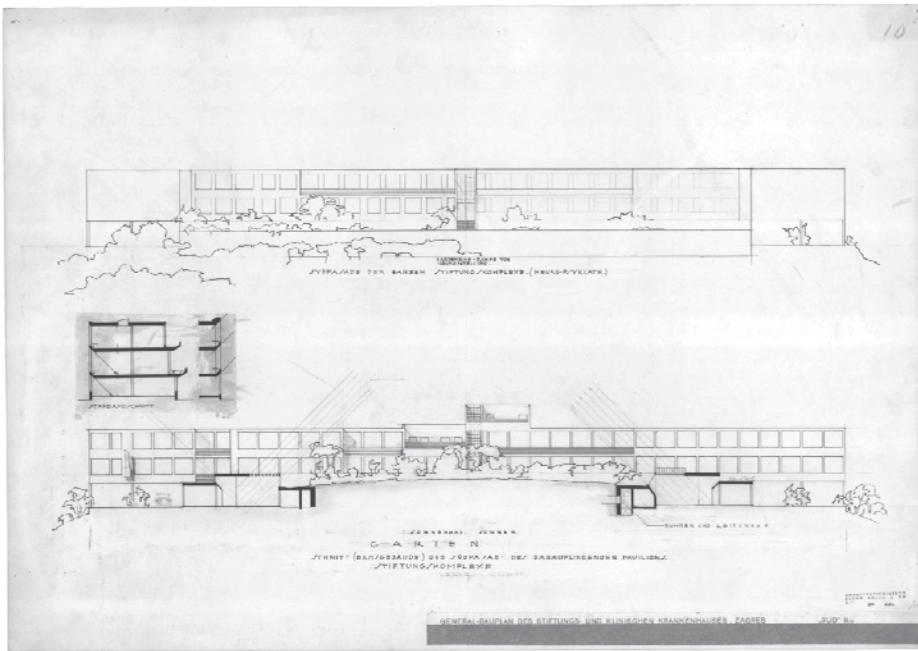

N5

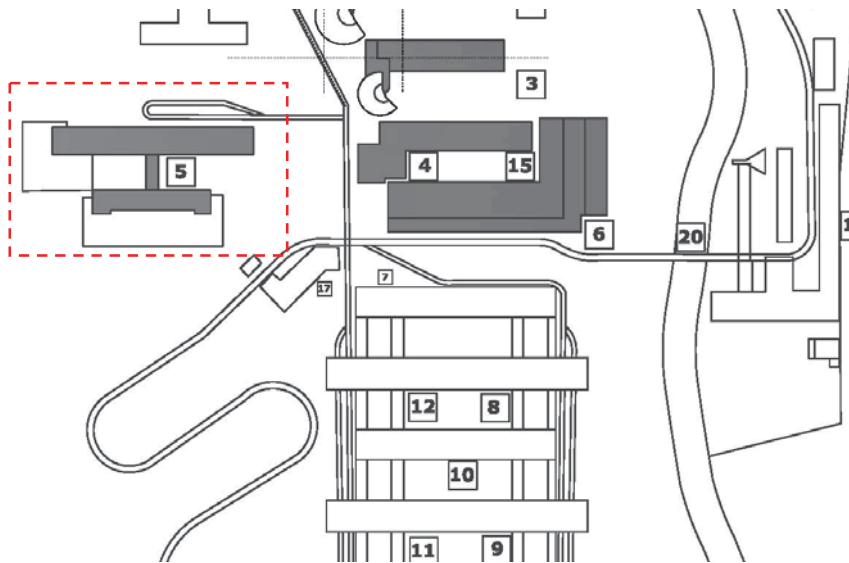

N6

FIG N5 - Neuropsychiatric clinic, façades and sections, 50/620, AAA
FIG N6 – Scheme of the location of the Neuropsychiatric Clinic, next to the main access from the city and the reception entrance building., next to the city.

ZONE 1

Clinics with the School Of Medicine

1. Surgery Clinic
2. Internal Medicine Clinic
3. Otorhinolaryngology Clinic
4. Ophthalmology Clinic

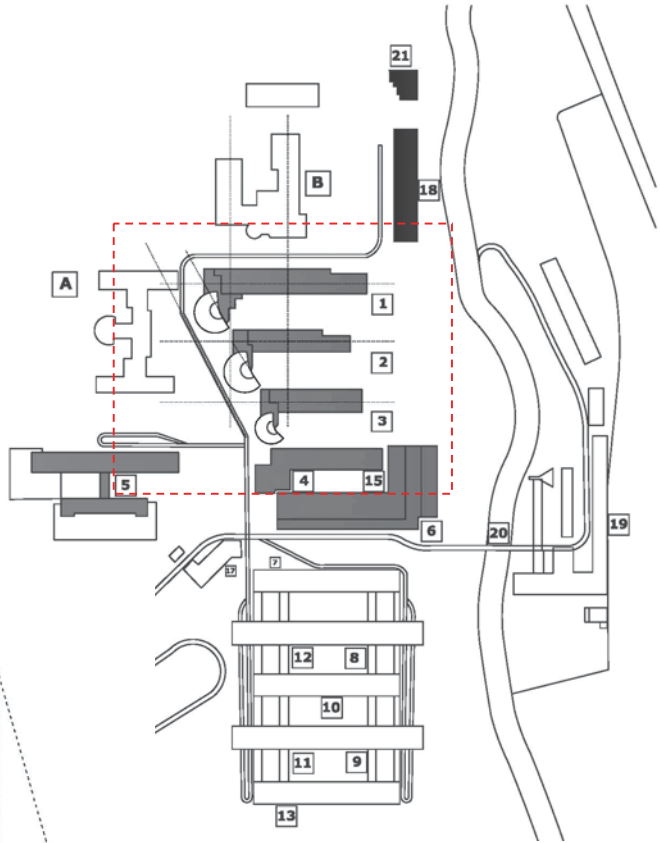
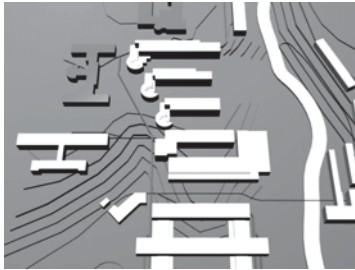

MAIN AREAS OF THE COMPLEX

- I** CLINICS
- II** HOSPITAL GENERAL
- III** CENTER OF RADIOLOGY AND PHISIO THERAPY
- IV** COMMUNITY SERVICE OF THE COMPLEX
- V** RESIDENTIAL AREA
- VI** SANATORIUM

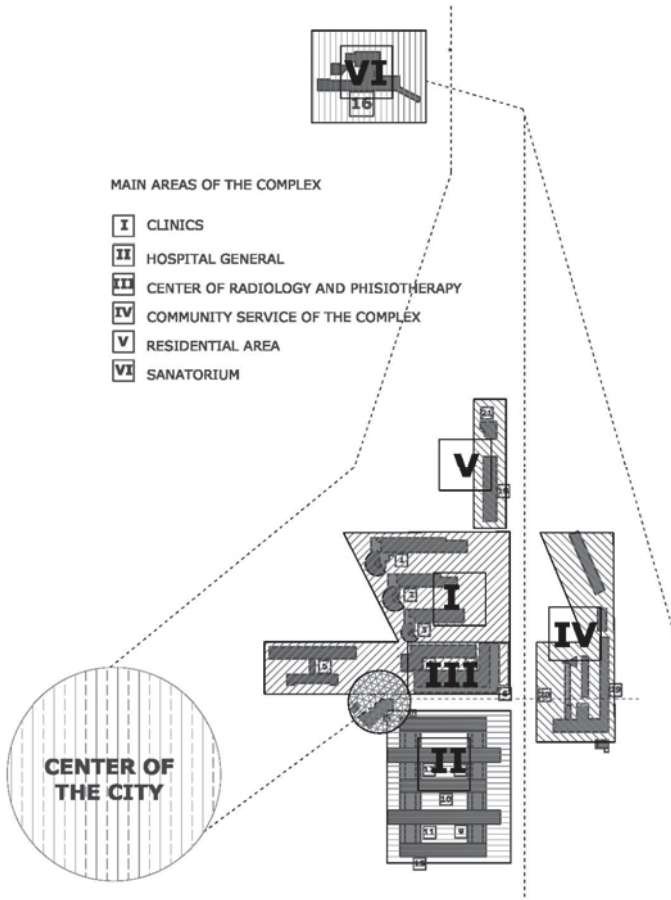

FIG C1 – segment of the four clinics of the north parth of the complex, (Clinics 1,2,3,4)

FIG C2 - Marked buildings in the northern part of the whole. (1) Surgery Clinic (2) Clinic of Internal Medicine (3) Clinical Otorhinolaryngology (4) Clinical Ophthalmology (5) Clinical Neuropsychiatry (6) x (15) Physical Therapy (18) Administration and Residential Building (21) Residential tower for medical staff

FIG C3 - Composition plan of the whole hospital complex , zoning



C4

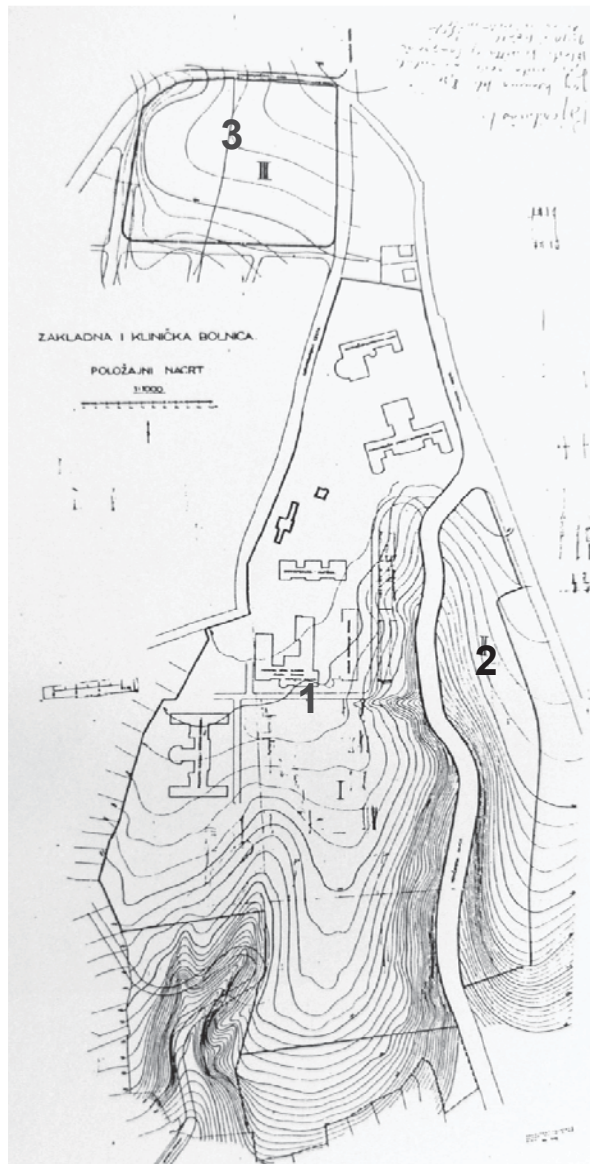

C5

FIG C4 – One fragment of the Plan of the city of Zagreb, (1923), scale 1:10000 50-608a, (source: AAA) (this map had all participants of the competition, marked with the rectangular site of the competition on the hill Siroki Brijeg and the center of the city of Zagreb (marked with the circle)

FIG C5 – Plan of situation of the competition, three main sites of the New Hospital Complex , 1- new hospital complex, administrative and residential , 2. – community service of whole complex (heating, installation, kitchen, washing center), 3- 1 km away from this 2 parts of the main plot, is reserved isolated terrain for the building of Sanatorium of Zagreb , source: AAA



FIG C6 - Map of Zagreb (1923.) with the marked location of the Competition for the new Hospital Complex: Salata hill: "Široki Brijeg", Gabric's plan of the old complex of the Clinics and the School of Medicine partial built from 1917-1930, source: Laslo, 2004

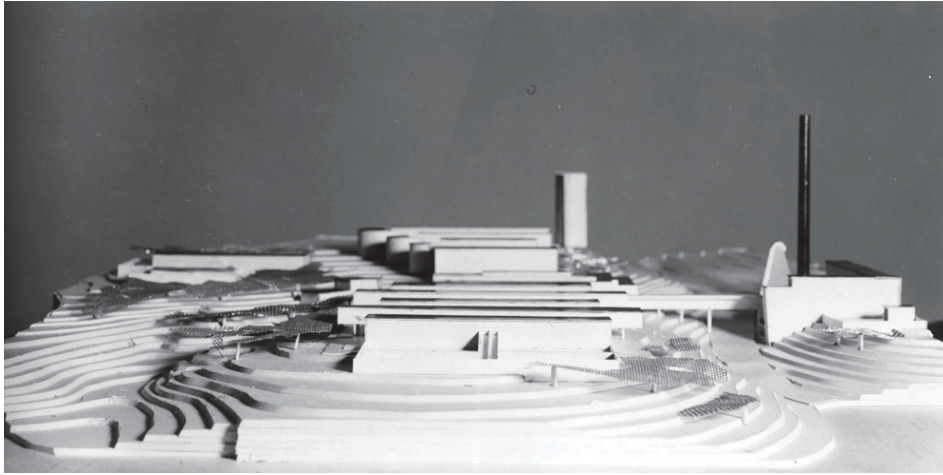

C7

C8

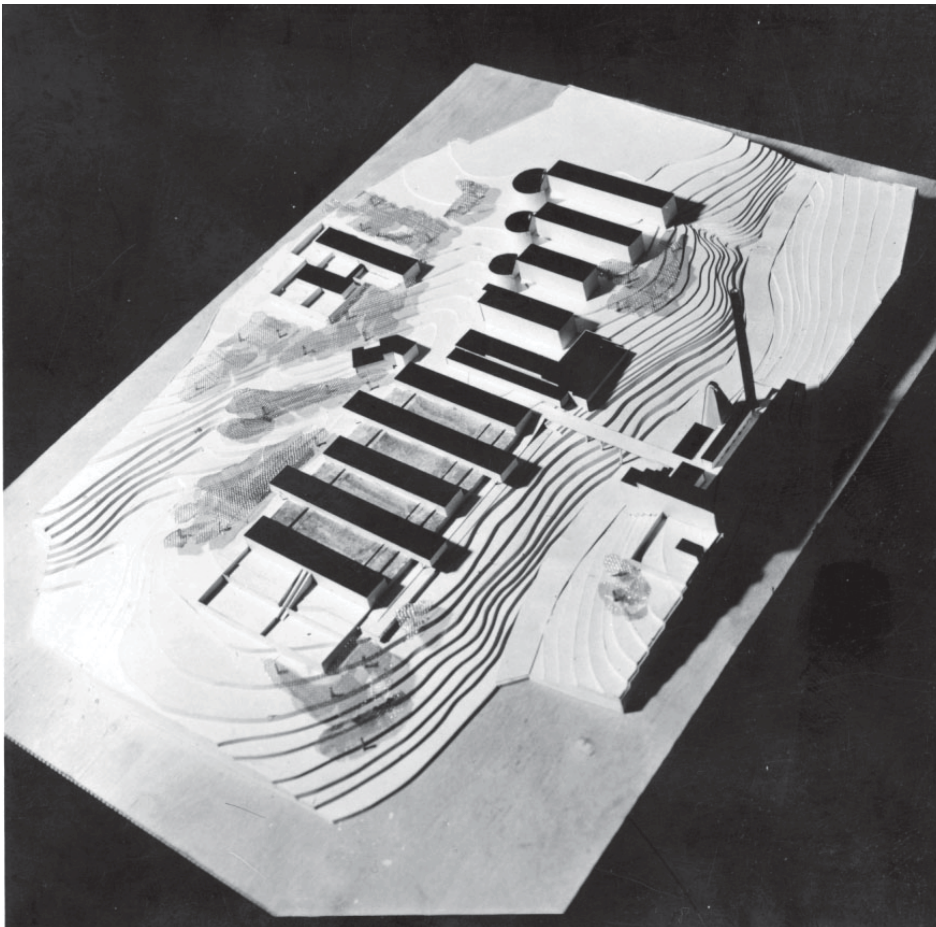

FIG C7 - Photo of Aalto's original model, HCZ competition entry, 1930-31, Aalto (view from the South "new" main center of the city (this model is not conserved in Archive of Aalto), source: AAA

FIG C8 - Photo of Aalto's original model, HCZ competition entry, 1930-31, Aalto (view from the South), source: AAA

EXISTING BUILDINGS OF THE CLINICS AND THE UNIVERSITY OF MEDICINE (1917-1930)

- A. Dermatology, Pediatrics and Otolaryngology , F.Gabric (1920-21)(Salata 4)
- B. Dean of the Medical University, Morphological-Biology and Physiological Institute, I.Fisher and F.Gabric (1917-1919) (Salata 3)
- C. Dental and Orthopedic Clinic,Egon Steinman (1929-1931) (Salata 6)
- D. Department Pathology-Anatomy, F.Gabric (1921-22) (Salata 10)
- E. Institute of Anatomy and Pharmacology, I.Fisher and F.Gabric (1917-19) (Salata 11)



FIG C9 Plan of the whole complex, with the main paths of the complex and access to the buildings. A,B,C and D are the existing building of the clinics and the School of Medicine (F.Gabric 1917-1939) behind the lot of the competition

The whole composition of the hospital complex of Aalto's proposal it could be observed as the "symphony" with established internal and contextual dialogue. The program of the competition is required to locate specialized clinics of the School of Medicine with lecture halls-amphitheaters (Part I) (Fig. C3, C5), next to the old clinic buildings of the School of Medicine. Aalto planned next to each of these three rectangular clinic buildings freestanding individual lecture halls, amphitheaters as the part of the School of Medicine, and next to one of the clinics he developed the rectangular lecture hall with "trimmed" corners (Ophthalmology Clinic). At the time of the competition on the hill, in this north part of the site, there already existed some buildings of the Old Clinics and the School of Medicine, as the one part of the general plan of the old Medicine complex, where previously some first buildings were designed by I.Fisher and the project of medical complex by croatian architect F. Gabric in 1917, where only four buildings were built of the old "medical campus" (plan of F.Gabric 1917) before HCZ competition (1930) on the Salata Hill "Siroki Brijeg".¹

Existing clinic buildings on the hill:

1. **(A)** Dermatology, Pediatrics and Otolaryngology Clinics of the School of Medicine, F.Gabric 1920 to 1921, today has the same use (Salata 4) (Fig.C11a,b)
2. **(B)** Dean of the Medical School, Institute Morphological - Biological and Physiological, Architects I. Fisher and F.Gabric, 1917-1919 (Salta 3), now Office of the Dean of the School of Medicine and Departments of Chemistry and Biochemistry, Histology and Embryology, Biology and Physiology. The last built clinics (not yet completed at the time of this competition 1930). (Fig. C10)
3. **(C)** Dental and Orthopedics Clinic, built by the Architect Egon Steinmann, 1929 -1931 (Salata 6), today Orthopedic Clinic.
4. **(D)** Department of Pathology-Anatomy, Architect F. Gabric 1921-1922 (Salata 10), now the Department of Pathology at the School of Medicine;
5. **(E)** Institute of Anatomy and Pharmacology, Architects I. Fisher and F.Gabric, 1917-1919 (Salata 11), now the Department of Anatomy and Pharmacology and laboratories of the School of Medicine;

¹ More detailed general information of the context of the competition: Bjazic T., *"Medjunarodni natjecaj za Zakladnu bolnicu i klinike Medicinskog fakulteta u Zagrebu 1930-1931 godine"*, Croatian Academy of Sciences and Arts, 2012, also some information can find from the article of Laslo A.: "Podijeljene muistot", Oris, 2004

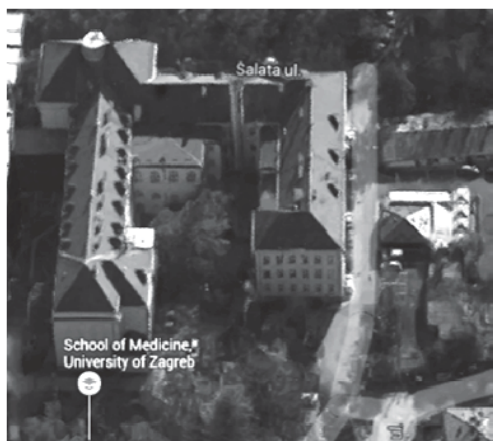

B



A

Source: Google Earth (buildings A and B)

C11b

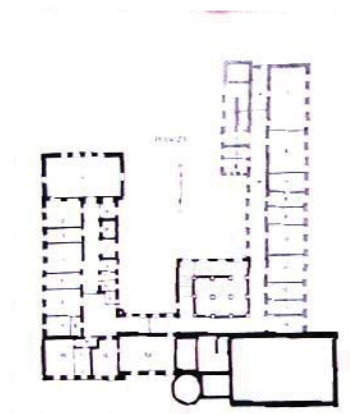

C10- building "B"

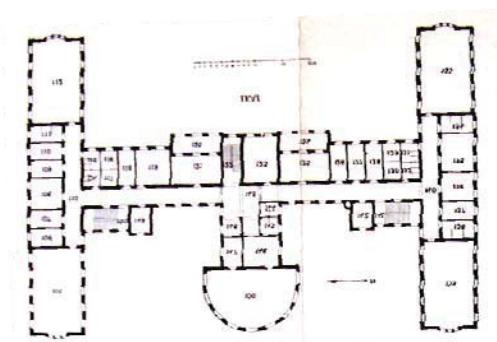

C11 a- building "A"

FIG 10 – Floor plan of Dean of the Medical School, Institute Morphological - Biological and Physiological, Architects I. Fisher and F.Gabric the year 1917-1919 (Salata 3) , (Teacher-training All-Male School (I. Fischer, 1911-1914))

FIG 11- Floor plan of the Clinic of Dermatology, Pediatrics and Otolaryngology at the School of Medicine, F.Gabric 1920 to 1921 (Salata 4)

Source of the photos Fig 10-11:

These photos are used for this research from the collection "Zagrabiensia" from the City Library of Zagreb (Gradske knjižnice u Zagrebu), *Sveučilište Kraljevine Srba, Hrvata i Slovenaca u Zagrebu : 1874-1924 : spomenica Akademičnoga senata*. U Zagrebu : Tisak Zaklade tiskare Narodnih novina, 1925. This documentation is consulted in the City Library of Zagreb : Archive Collection: "Zagrabiensia" , consulted in july 2011.

FIG C11b– Semicircle annex of the main façade of the Dermatology, Pediatric and Otolaryngology Clinic of the School of Medicine, F.Gabric 1920 to 1921 (Salata 4)

In 1923, eight years before this competition, the Zagreb General Urban Plan was completed, including a development plan for the future years and the biggest problem was to solve this hospital complex on the hill "Siroki Brijeg", Foundation Hospital with specialized clinics and the lecture rooms of the School of Medicine as by 1930 School of Medicine did not have enough capacity and did not have adequate spaces distributed throughout the city.²

Old clinic buildings next to the site of the competition will be important references for the new forms and compositions of the Aalto's new hospital complex competition entry.³ Clinic buildings of the School of Medicine, founded in 1917⁴, where the first buildings were designed by Croatian architects I.Fisher and F.Gabric at the "Siroki Brijeg" hill where a total of five pavilions are planned as the theoretical parts of the School of Medicine complex and nine pavilions are made for seven clinics. Due to the difficulties of the realization, there had only been completed a part of the first idea of the "hospital city" on the hill Siroki Brijeg, and this idea re-appeared after ten years through this important international competition in 1930.

Although the Central Hospital was never carried out as a joint project between the School of Medicine and all clinics, we could confirm that F.Gabric had given some initial important references for the new project, as we observe in Aalto's competition entry from the plan of the city (scale 1: 10000) (Fig 4), where these old hospital buildings were integrated into the General Plan of Zagreb. This plan was received by all participants in 1930 within the complete documentation of the competition.⁵ By analyzing the plans of existing buildings of the clinics and the School of Medicine, placed next to the limits of the lot 1 of the competition, it can observe that all these buildings have the classical elements composed of the "body" of the building as the rectangular element, and annex elements, one "body's" corner (circular or rectangular) as a "head" of the composition. (Fig C9-11).

² Laslo A., "Podijeljene muistot", Oris, 2004, p.110-131

³ This relation also confirmed Laslo A. (Oris,2004), Radovic D. (1995)

⁴ Also, could be find more details, informations and drawings of ancient clinics in the book :*Sveučilište Kraljevine Srba, Hrvata i Slovenaca u Zagrebu :1874-1924:spomenica Akademijnoga senata*. U Zagrebu : Tisak Zaklade tiskare Narodnih novina, 1925. And book : *Medicinski fakultet u Zagrebu : 1917 - 1997 / [glavni urednik Anton Švajger]* Zagreb : Medicinski fakultet Sveučilišta, 1997./ This documentation was consulted in the Central Library of Zagreb : Archive Colection: "*Zagrabiensia*", consulted in the year 2011./2012)

⁵ A.Laslo, Oris, 2004,p.110-131

It is possible that these existing forms on the site were the first references and inspirations that guided Aalto to reinterpret by juxtaposition collage of two elements of different nature⁶ of the clinics and the School of Medicine. Aalto has analyzed this site context and thus developed one dialogic space and unique, uniform image viewed anywhere from the city designed as one logic and organic composition as the "body spine", geometrically correct, followed the terrain limitations, lot configuration, main topographic lines and the best insolation, ventilation and wind protection by using the methodology of decomposition.⁷ He established a dialogue between the new and the old School of Medicine complex buildings, until that moment chaotically placed on the hill where he probably wanted to integrate both hospital complexes in the one kind of the unique "hospital city".⁸

By analyzing the site map of the city with old hospital complex building plans (1917-1930) and studying Aalto's early sketches and urban composition of the new medical complex, we can probably relate these context buildings as the important references of the composition and their rectangular and "semicircular" annexes analogous to the composition with the auditoriums of Aalto's proposal. Aalto's West complex facade reinterpreted the characteristic context of elements by the semicircular amphitheater of the three clinics that lie at the highest ground level, behind the old clinic building. His new facade system causes a dialogue with the built context by using the open and modern system which integrated the Nature with the built context.

These principles of the new hospital complex were designed together with the built site context, which is different from many proposals of this competition, where participants expressed pure ideas of "international style". Aalto formed one uniform image of the new complex in the context and didn't develop something as the autistic composition separate within their "natural" base. Associations of the new forms are based on the images from the local context, ancient cultures, and the competition program guidelines.⁹ The analysis of these ideas is important to understand the future use of these analogous elements of Aalto's architectural and composition language, the leitmotifs of his trajectory.

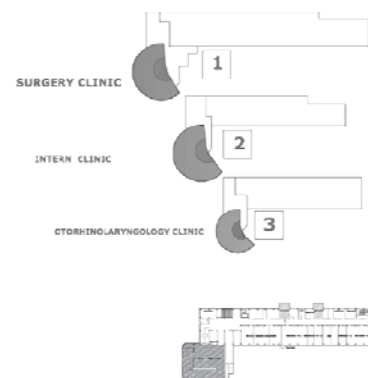

⁶ Anton Capitel, "La arquitectura compuesta por partes", 2000

⁷ That decomposition system has applied previously on the Sanatorium in Paimio (1929-1933) ⁸

The climatic conditions and required orientations of this project and this conditions could be find in the text of the competition program.

⁹ Attached the original of this program in the Annex of this thesis

Three clinics (Surgery, Internal Medicine, and Otorhinolaryngology Clinic) are analogously composed with the School lecture halls and differ by their sizes and respectively, interior distribution is connected with the rectangular buildings. Aalto developed the composition with two segments of different "nature"¹⁰, rectangular and circular, connected by another "mobile" element as a kind of a "neck" of the body which gives it an organic "movement sensation" (the part which connected the rectangular pavilion Clinic and $\frac{3}{4}$ part of the circle shape). The School clinics are three-story rectangular buildings. Aalto placed clinical departments and the necessary spaces of the School of Medicine, laboratories, ambulances with three independent entrances on the ground floor of the clinic buildings. On the upper floors, he planned the hospital and operating rooms. The small operating rooms are placed directly next to the center hall of the clinics upper floors, where Aalto wrote in his description of the project that is more necessary for that area. (Fig C12-14)

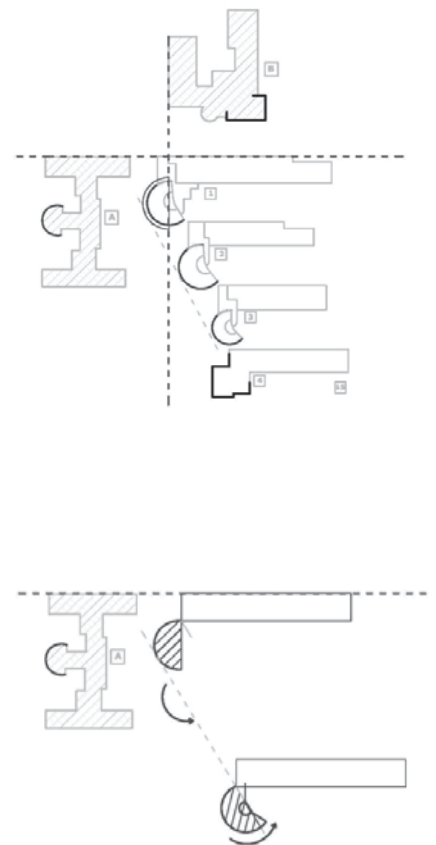
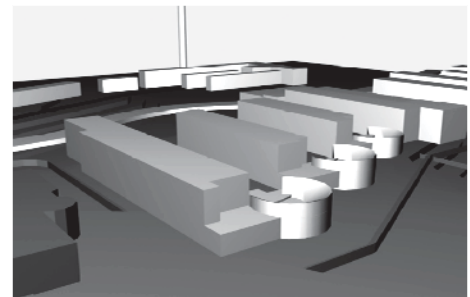
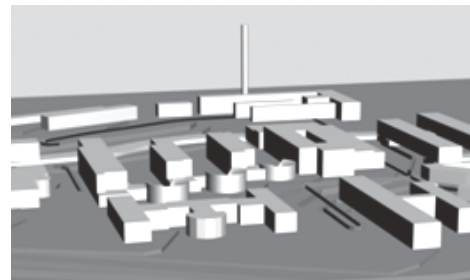
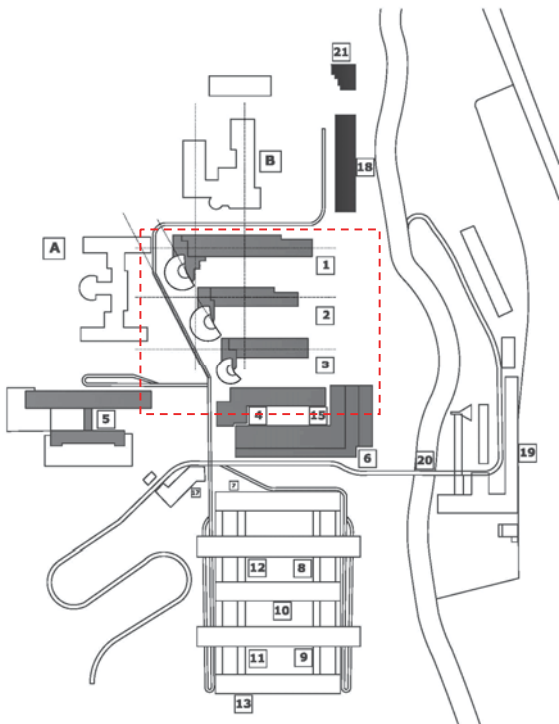

FIG C12 - Schemes, re-interpretation of the elements of the existing buildings and the moment when Aalto made asymmetry composition rotating the auditorium and make extension in the opposite direction of the clock

¹⁰ Anton Capitel use in his book "La arquitectura compuesta por partes", 2009, p177

CLINICS: 1.Surgery Clinic, 2.Internal Medicine Clinic
 3. Otorhinolaryngology



C13a,b,c,d

FIG C13a,b,c,d—3d model of the composition of the three clinics

FIG C14 – Segment of the photo of the original model of the North of the complex. Three clinics with auditoriums, Decreasing order, source: 103792, AAA

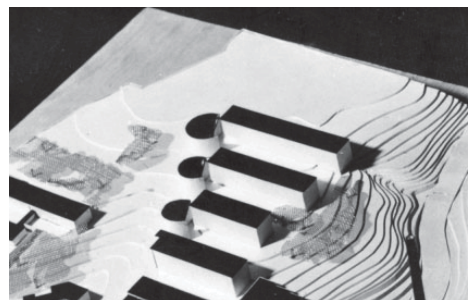

C14

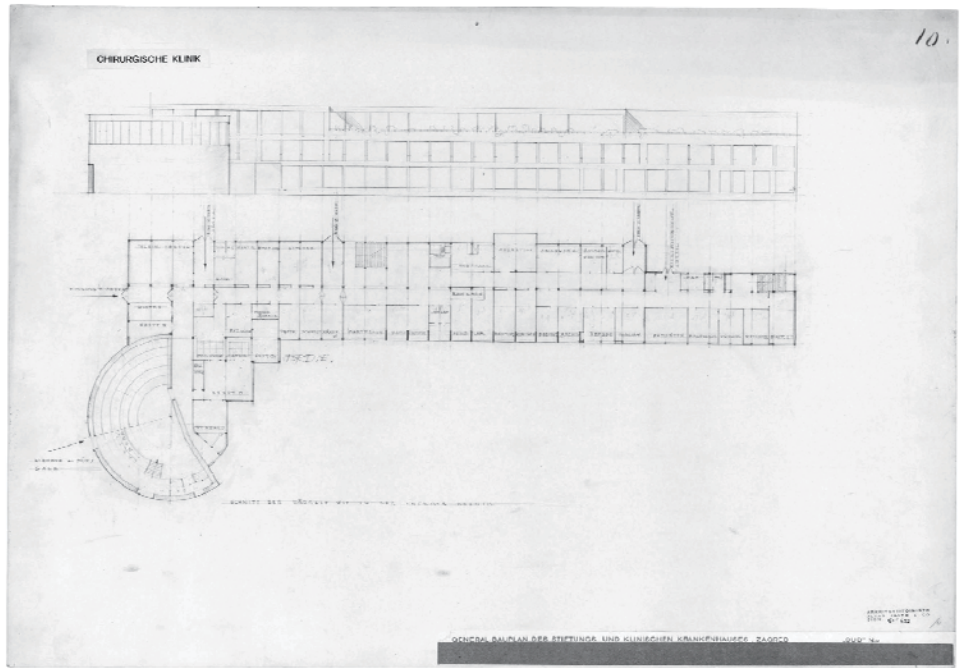

S1

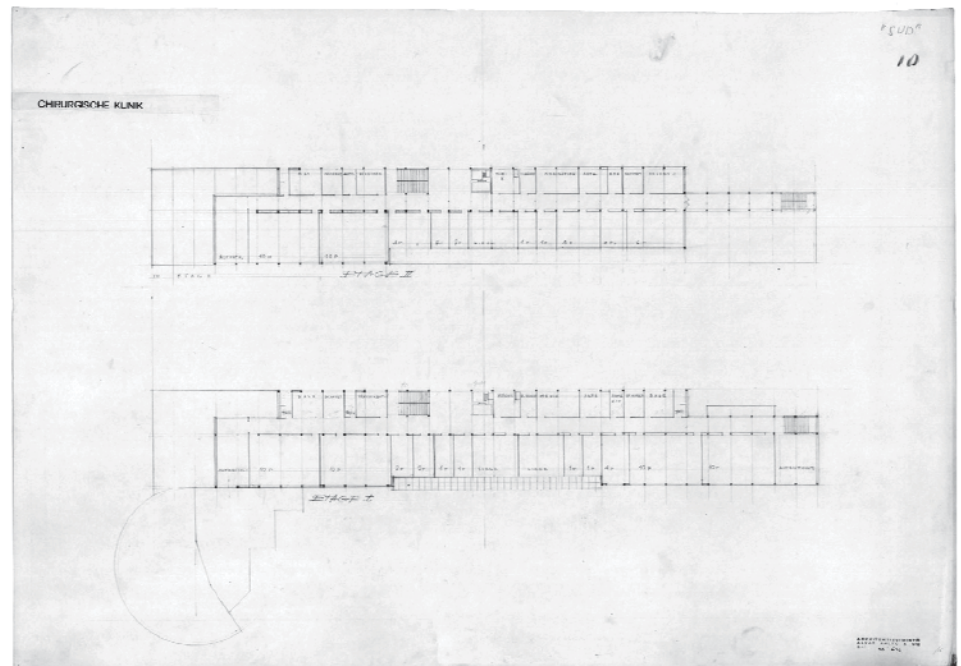

S2

The Surgery Clinic has the biggest capacity of the all clinics located in the north part of the hospital complex.(Fig S1-2). For that reason, Aalto created the biggest lecture hall-Amphitheatre for this clinic in the north of the complex, behind the existing Pediatric and Dermatology Clinic (of 1920-21, F.Gabric). This information is important to understand the future application of the principle of decreasing order of the three clinics by the diagonal path. The specialized clinical spaces Aalto divided into several different groups depending on their use. Outpatient units and the spaces of the School of Medicine were placed on the ground floor because in doing so patients and students of the School of Medicine could enter into this space directly from the outside, through their separated entrances independent for the patients and employees of the clinic. The program required that the connection between these two groups of space not be necessary, and also, it is not advisable. It is only necessary to make a possible interior connection on the way that clinics employees may enter to all groups (of the clinic and school spaces).¹¹

It required that the teachers of the School of Medicine and their lecture and preparation spaces have a connection with the operation rooms as a school medical practices could be held as well. We could conclude for which functional reason Aalto here developed the idea of the stepped annex of the amphitheater. There he had to organize the operations rooms, also placed on the ground floor in the way that isolates and protect this operational area from the circulations inside the clinics where Aalto planned the annexed spaces for the staff of the School of Medicine next to the lecture halls, on the ground floor, but at the same time connected with the clinic. The stepped annex form he developed because the interior organization, privacy and insulation. The stepped annex on the ground floor he used in many other projects.

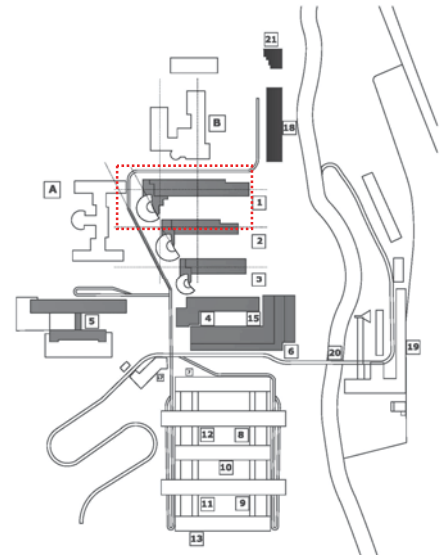

¹¹ More about the composition, forms and all relevant characteristics of these three specialized clinics in the north of the complex (Area I) will be analyzed in the next part of the three similar clinics, through the four main principles "extracted" in this part of the complex. Head and Body, Classical Amphitheatre, Repetition of the same "species" with decreasing order, New daylight system, where each of these principles will be analyzed separately as the important elements of Aalto's architecture language.

FIG S1 – Ground floor of the Surgery Clinic and façade, Aalto, 50/622, source: AAA

FIG S2– First and second floor of the Surgery Clinic and façade, Aalto, 50/623, source: AAA

The Internal Medicine Clinic is located in the north part of the hospital complex, between the Surgery Clinic on the north and the Otorhinolaryngology Clinic in the south. This clinic has the analog compositions, forms, and organization of the interior spaces like the Surgery clinics. However, this clinic has less patient bed capacity and the surgery spaces without an annexed part of the operating rooms on the ground floor, placed next to the lecture hall (as in the case of the first placed Surgery Clinic). Instead of surgical annexes, Aalto placed annexed organic curved form of the Lecture Hall entrance and at the same time this entrance lead to the clinic by the isolated curved hallway. Amphitheatre and the entrance created the one organic form of a "snail", connected by the "neck"- hallway as the spatial organism in "bio-mechanic movement". Groups of spaces for this clinical practice, students and teacher departments are placed on the ground floor. On the other side, Aalto placed outpatient units also on the ground floor and connected them by the independent entrance to the clinic and the lecture hall. Aalto designed two independent lecture hall entrances for the three clinics. One external and one internal, which were connected with the clinic. On the upper floors, he located all hospital rooms oriented toward the south (as required the competition program). (Fig I1- I2)

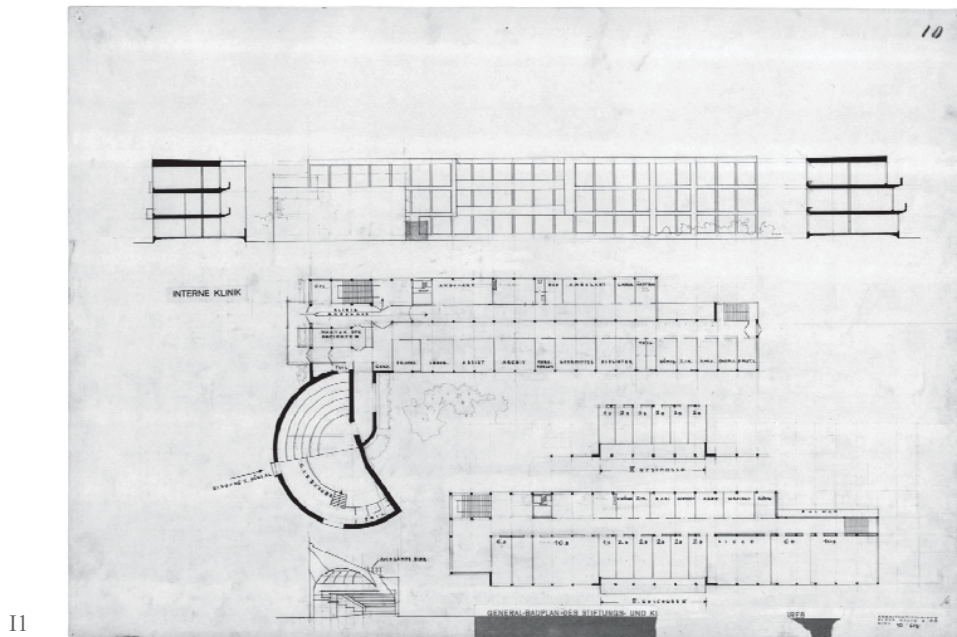
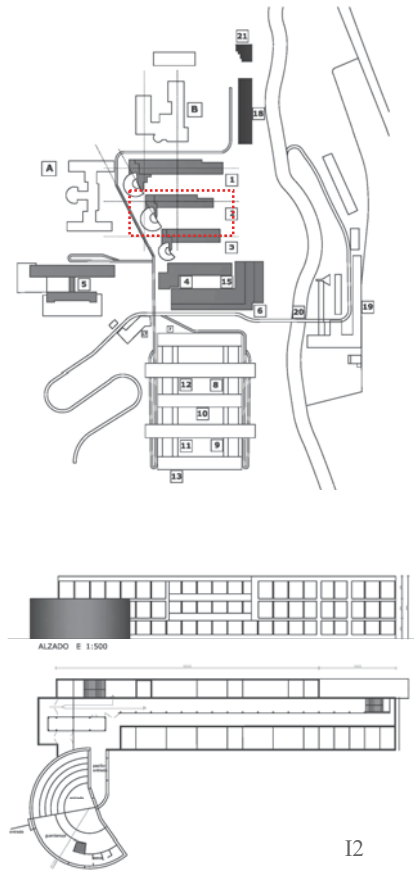

I1

FIG 11 – Final drawing of the Internal Clinic for the Competition entry of Hospital complex of Zagreb, (1930-31), Aalto, source: 50/615, AAA

FIG 12-Internal Medicine Clinic of the hospital complex of the proposal of Aalto, asymmetrical composition "in the bio-mechanical movement", with the lecture hall-Amphitheatre

The Otorhinolaryngology Clinic is a smaller version of the Intern Clinic. Aalto applied the same order of the three clinics respected the order of the program of the competition and the necessary capacity of the spaces of three clinics. In this way, he created the one decreasing order of the compositions, and additionally he created a composition with diversified character of the small individual pavilions that protected each others and proved the best source of the light. The Otorhinolaryngology is the smallest clinic of these three clinics of the north of the complex, with similar features and similar interior organization of the clinic spaces with the University of Medicine in the ground floor and the patient rooms in the upper floors.

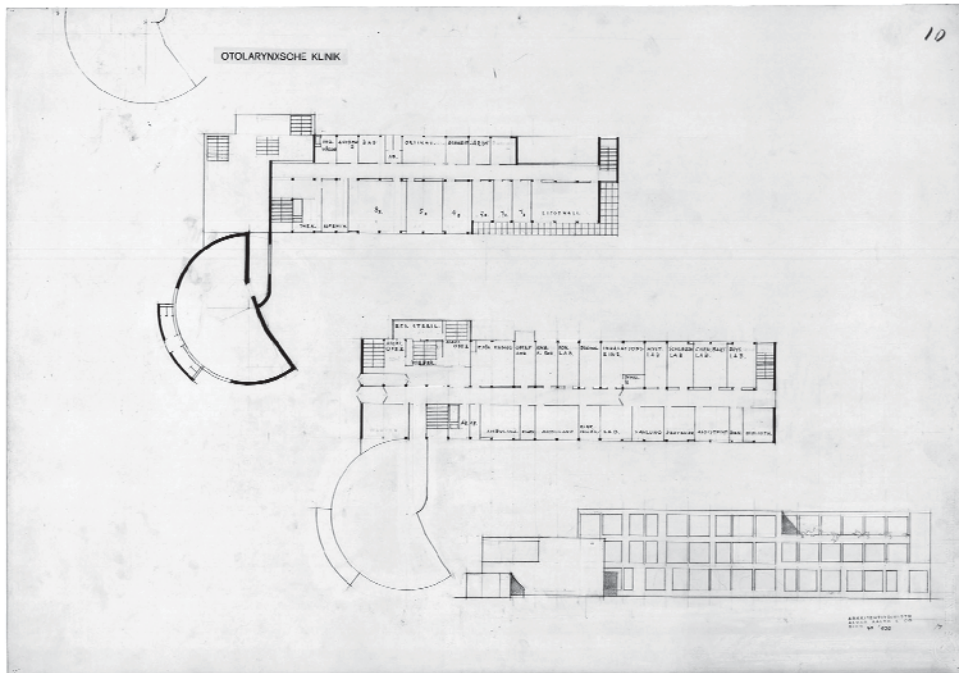
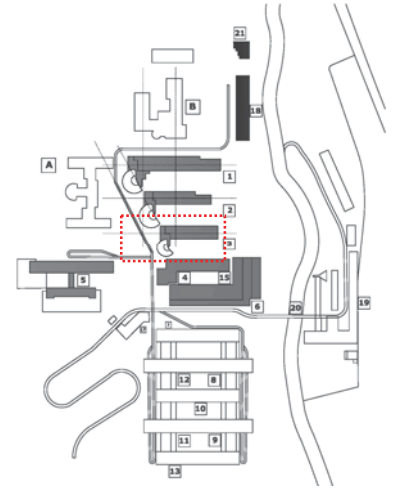

FIG OT1 Final drawings of the Otorhinolaryngology Clinic for the Competition entry of Hospital complex of Zagreb,(1930), Aalto, source: 50/626, AAA

"The reason for the amphitheater, almost an obsession in the work of Aalto course is an explicit reference to antiquity".

Pallasmaa Julhani, Images architecture, AV Monographs 66, 12 July-August 1997

ZONE 1

PRINCIPLE 1

**Head and Body
in Biodynamic movement**

PRINCIPLE 2

**"Head": Amphitheatre
Lecture Hall "Sacred Temple"**

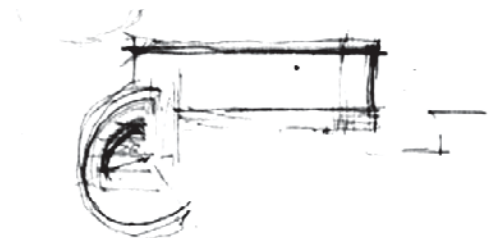

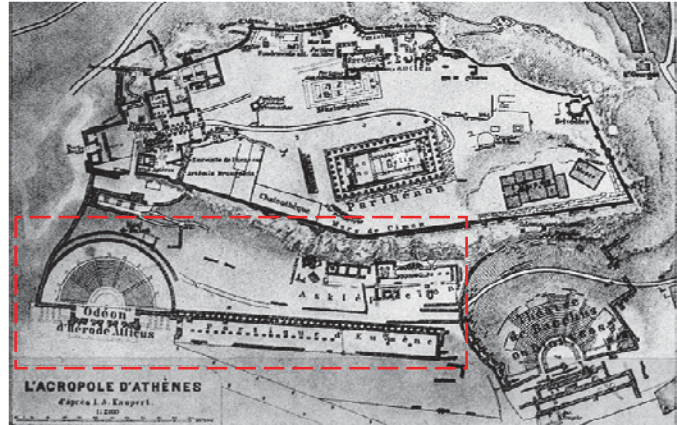

A1



A2

FIG A1 - Map of the Acropolis with all buildings and the Amphitheatre Odeon has one similar composition if we make a comparison with the composition of the two elements of different nature (semi-circle and rectangle)

source: www.grecotours.com, web visited 10.09.2015.

FIG A2 - Photo perspective of the Amphitheatre Odeon of Acropolis. source: Wikipedia.org

FIG A3 - Central Public Library, Stockholm, 1922-24, Asplund



A3

In the competition entry description, Aalto called this site: "Acropolis".¹This possible connection with Acropolis conduct to the other analogs themes of the composition of the "head"– the amphitheatre and "body" (Fig A1), rectangular clinic building, as the building of "Odeon" observed from the map of the Acropolis, where perspective view of the amphitheatre (of $\frac{1}{2}$ of the circular base) is possible observed from the angle as $\frac{3}{4}$ circle form. (Fig A2)

A circular and semi-circular form of the amphitheatre also had an influence on Aalto from the Asplund's forms and his Central Library of Stockholm (1922-24) (Fig A3), where Asplund had the inspiration of the monumental circular form of *Rotonde de Villette* of Ledoux from Paris,1784-1788. We could find a similar composition with the semicircular hall from Sven Markelius (Sweden representative at CIAM) and his building Helsingborg concert hall (1926-1932) where for his building, Gustav Lyon has designed an acoustic baffle.

Aalto was very interested in the acoustic characteristics of the buildings and before this project he experimented with the open-air acoustic stage for the Exhibition in Tampere (1922) (Fig A4), Seinajoki (1924) (Fig A5), the acoustic spaces of the Building of Defence of Jyvaskyla (1924) and theatre of the Agricultural Cooperative Building in Turku (1927/28) (Fig A6). In an unrealized project, Cinema Suomen Biografi (1928) (Fig A7) he applied the trapezoidal form of the Gustav Lyon's Salle Pleyel (1924) but it was not proper to use this form for the cinema (which needs different acoustical properties of the concert hall). Aalto experimented these acoustic properties of the spaces during whole his trajectory, and also he used analogous forms for the other functions (religious, culture, administrative buildings or libraries). Sequentially he also designed a more detailed open-air stage for the Exhibition of Turku (1929) (Fig A8,9). After the project of the lecture hall of the School of Medicine of Zagreb, Aalto has not used this form of the classical Amphitheatre during many years, almost until the 1950s (probably because he wanted to research more acoustic features of this type of buildings)².

¹ Aalto, *Arkkitehti XII*, 1932, P.5-6,

² Norvasuo Markku, *The Amphitheatre and fan-shaped forms: Acoustic forms in Aalto's auditorium designs*; The Alvar Aalto Academy, Helsinki, Ptah, 2006:2,

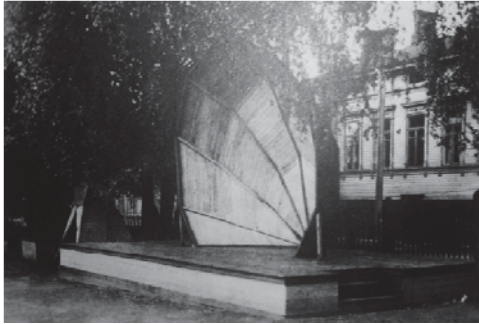

A4

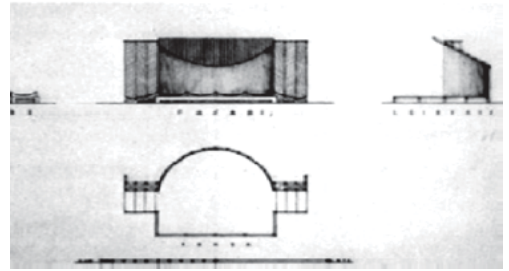

A5

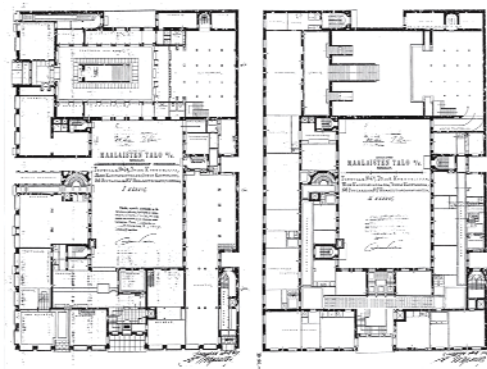

A6

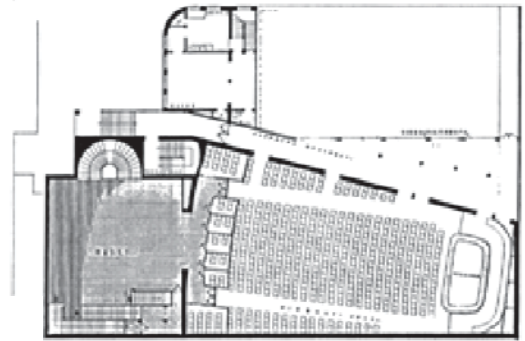

A7

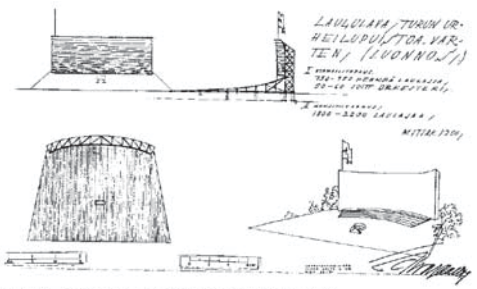

A8

Dibujo del escenario para actuaciones en la exposición. A. Aalto

FIG A4 – Stage at the Exhibition in Tampere, 1922, Aalto, source: Domiguez,2003

FIG A5 – Stage of Seinäjoki, Aalto, 1924, (semicircle open-air backstage (acoustic),Schildt,1994a

FIG A6 -Agricultural Cooperative Building, Turku, Finland, Aalto 1927-28, Sc hildt, 1994a

FIG A7- Cinema "Suomen Biografi", Turku, Finland, 1928, floor plans (re-interpretation of the Salle Pleyel of Gustav Lyon) , Schildt 1994a

FIG A8- Stage of the 700. Exposition in Tutku,1929, source: Schildt, 1994a

FIG A9- Stage of the 700. Exposition in Tutku,1929, source: Domiguez,2003

FIG A10a,b- Alppiharju open-air theater (unrealized), Aalto, 1935 , Schildt 1994a, 45/107 , AAA

FIG A11- unrealized project of big open-air theatre and concert hall Avesta in Sweden which Aalto elaborated with Albin Stark (1944), AAA

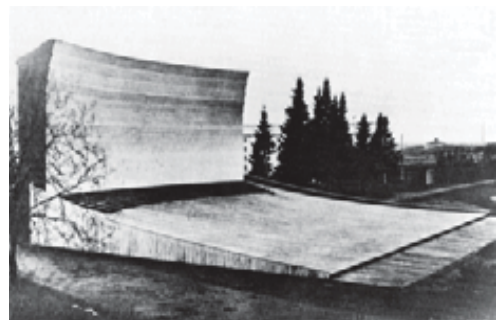

A9

Aalto only developed during that part of his trajectory, one small project of the open-air amphitheater of Alppiharju open-air theatre which he made in 1935 (Fig A10), and one complex, but unrealized, of the competition for Avesta theatre in Sweden. He developed that project with Albin Stark (1944) which contains a big open-air theatre and concert amphitheatre (Fig.A11). Town plan for the city Avesta was entitled "Acropolis" because the main motives of the amphitheatre and "temple" were implemented and the same denomination he used for the site of the competition for HCZ.³ Town Hall of Avesta combined theatre, concert and meeting hall, where in this project, are recognize the elements of the previous project for the competition of the Valilla Church, 1929 (Fig A12a,b).

A section of the background of the stage and semi-cylindrical large form of the body of the church were featured in a form of Le Corbusier. In the first competition entry of the Tehtaanpuisto Church in September 1930, a year after the competition entry for Valilla Church, Aalto considered similar floor plan and the ceiling system, but he was not awarded in the Valilla Church competition due to the proper sound one-way direction and for the improvement of the acoustic of this church's interior, and he later created the special system of the acoustical ceiling of the semi-cylinder segments forms with the two-way passage of sound waves between the altar and the organ (Fig A13a).

For the acoustic reasons, Aalto at the beginning developed the trapezoidal form as the best acoustic form, viewable in the first sketches of the amphitheatres of the three University Clinics of his competition entry for HCZ. Until the last phases of his trajectory, Aalto believed that trapezoidal form has the best acoustic features for the concert hall. For acoustic reason in Melnikov's Congress Hall of the Rusakov Workers Club (1927) (Fig A14), is adapted a new "fan shape" in the form of the circle with the square elements that coming out from the round basis, and that system Aalto will be used in the Finland Hall, Wolfsburg center and many other projects.

³ Schildt G, 1994, p.83. Aalto called the project of Avesta: "Acropolis" and in the article published in *Arkkitehti* 1932, Aalto wrote that the place of the new Zagreb hospital complex is as Acropolis in the city on the hill, close to the city center, viewed from any point of the city

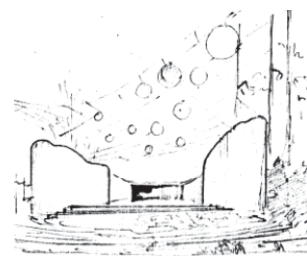
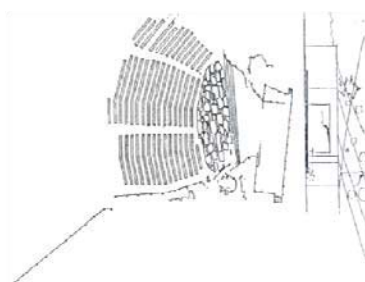

A10a,b

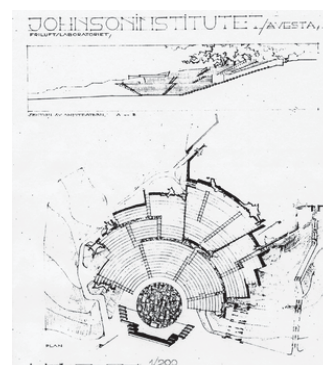

A11

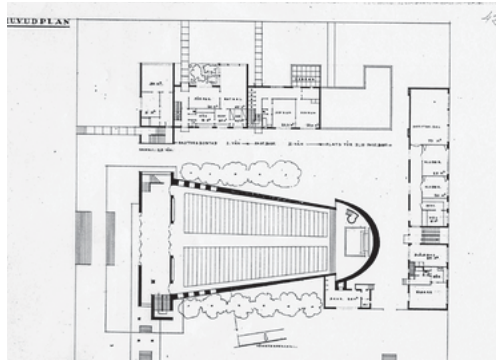

A12a,b

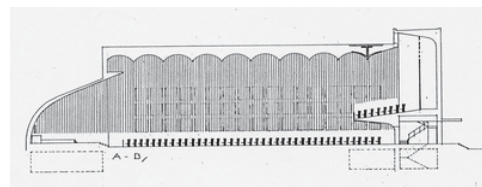
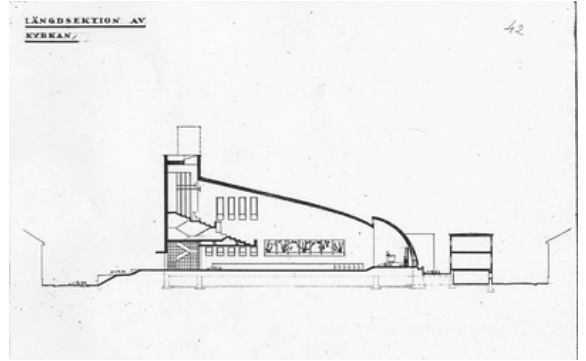

A13a,b

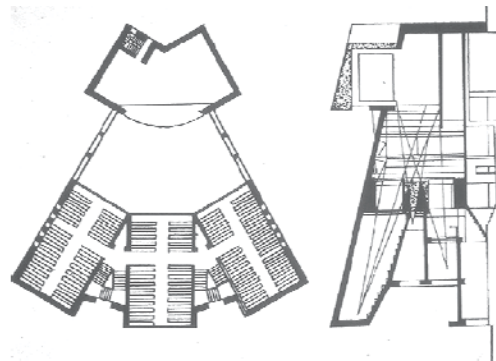

A14

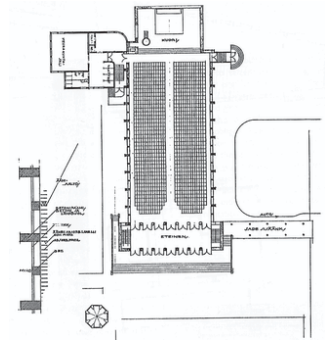

A15



A16

FIG A12a,b - Competition entry for Valilla Church, 1929 (unrealized project), Aalto, source: Schildt,1994a, AAA

FIG A13a,b Competition entry for Tehtaanpuisto Church,1930(Unrealized project), Aalto, source: Schildt,1994a

FIG A14– Rusakov Club of workers, 1927, Moscow, Melnikov

FIG A15 Project of Competition entry for the G.A. Serlachius Co. headquarters, 1929, Aalto (unrealized), source: Sschildt,1994a (AAA)

FIG A16 – Pärnu Spa building, 1927, Estonia, Aalto

(the first international competition), source: Schildt, 1994a(AAA)



It can define some main development sources of the creation of the composition: head and body in biodynamic movement, which Aalto applied in this competition entry for HCZ in very authentic way as the spatial organism made by circular and rectangular form.

The main sources of the new principles from this competition and for the first two principles: PR1 and PR2, coming from the site of the competition, "sense of place", and requirements from the program.

In the northern part of the complex with University Clinics can be found the beginnings of the creation of the mobile and organic compositions, where he forms the individual lecture halls- amphitheatres as the "heads" of the freestanding elements inclined and connected by the one "small rectangular mobile elements": "neck" to another rectangular element of the composition "body", as the **bio-dynamic mobile composition** which will be one of the Aalto's main leitmotifs along all his trajectory, with many variations and different uses.

By analyzing the Aalto's early drawings we can follow the process of the development of his ideas and this composition of "head and body" and development of the form of classical Amphitheatre-Lecture Hall. Aalto first developed different versions of this composition which we can recognize in his future works. He was interested in theatre, film, music, and all spaces deals with acoustics and in his description of the amphitheatres of the clinics of the HCZ, he called "acoustic classrooms", where he wanted to provide the best acoustic features for the Lecture Halls of the School of Medicine and because that we can observe that these first versions of the Amphitheatre was influenced by the principles of acoustic of Salle Pleyel (Gustav Lyon, Paris, 1926), one concert hall with the best acoustic characteristics in that time. It can observe on the early sketches that he developed the initial versions where from the rectangular base-annex "coming out" the "wedge-shaped" auditorium (Fig A17-21). This is composition which Aalto will use on many of his later works, as Finland concert hall (with the similar "wedge-shaped" concert hall) or Seinäjoki building.

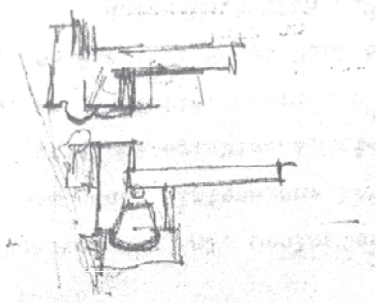
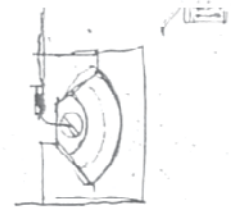

A17-
A21

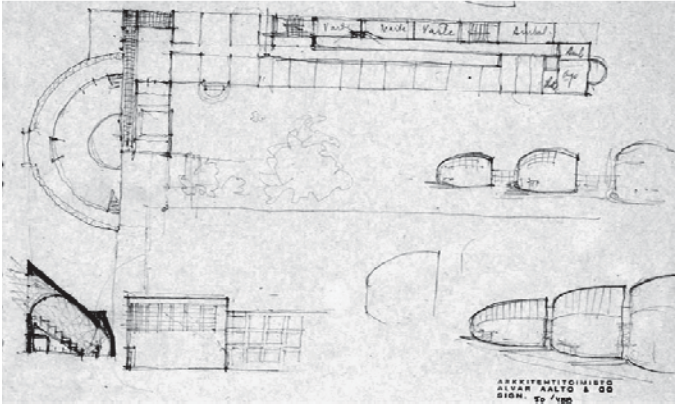

A22

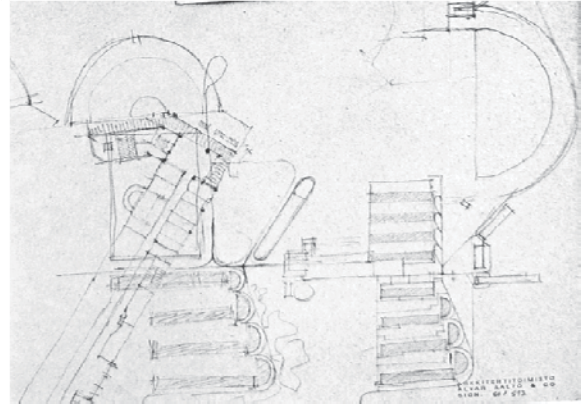

A23

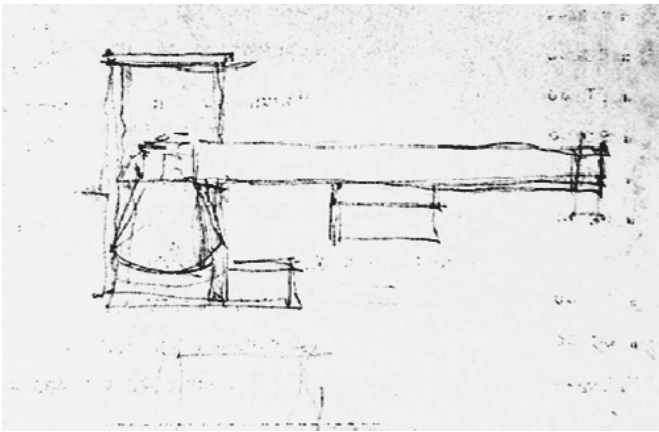

A23a

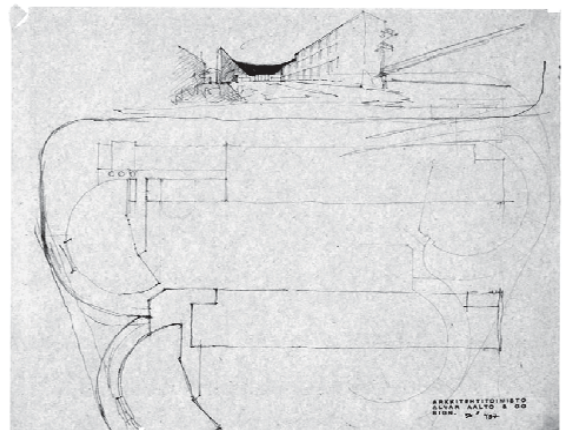

A24

FIG A17-21 – Early sketches of the composition of the clinics, with wedge-shaped lecture hall, source: Schildt, 1994a (AAA)

FIG A22- Early sketch of the Clinic with the Auditorium of half circle, source: AAA

FIG A23- Early sketch of the Clinic with the Auditorium of half circle, source: AAA (rotation of the angle, first rotations of the rectangular part "body" of the composition)

FIG A23a – Early sketch, one version of the composition of the clinics of the north, HCZ competition entry, Aalto, source: AAA

FIG A24 - Early sketches of the Clinics, composition with auditorium, source: AAA

FIG A25 - Early sketch of the Clinic of Ophthalmology, also with circle amphitheatre, composition with auditorium, together with Radiology and Physiotherapy

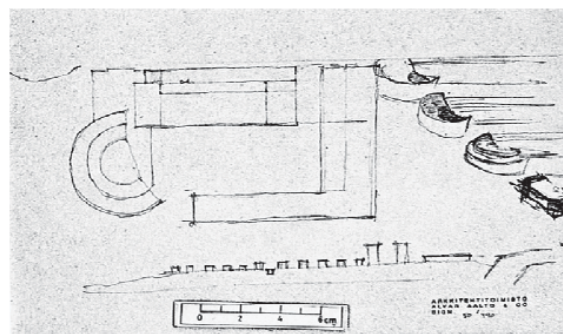

A25

a. Competition program required to place all specialized clinics in the north part of the lot, with all patient rooms oriented to South (for that reason Aalto was developed the system of the parallel pavilions with all patient rooms oriented toward the South and the gardens between the pavilions), and also, the program required to design the Lecture Hall of the University of Medicine next to these clinics connected with them, but without any conflicts with the student circulations in the clinic area. For that reason, lecture hall needed a set of independent entrances, and, also, the competition program required to develop the lecture hall – *amphitheatre*.

b. Influences from the compositions of the built context of the site: Behind the lot of the new hospital complex on the "Salata" hill are located the old buildings of Clinics and the School of Medicine (General Project of the old Hospital complex with the School of Medicine, started to develop since 1917, where just one part of five buildings was realized until the year of this competition).

The composition of the first center-facing old clinic building (Dermatology and Pediatric Clinic, F.Gabric, 1921-22) on the hill, with the semi-circular annexes, clearly affected the "head" of the composition (amphitheatres-lecture halls) and rectangular "bodies" (clinic buildings) of the Aalto's future University Clinics, planned just behind this old clinic building and analyzing the Aalto's early sketch of the three clinic compositions on the north of the complex, these direct influences are observed. (Fig A22-25)

On the first sketch, it can be observed that this composition of the head and body had more rigid, classical composition with the Lecture Hall of the School of Medicine with the shape of $\frac{1}{2}$ of the circle, similar to the annex of the main façade of the existing, old Pediatric, Dermatology Clinic. (Fig A26-A30) Having in mind the context of the place and the competition program, we can contemplate the "organic" origin as the reinterpretation of the main facade of the old building of the



A26a



A26b

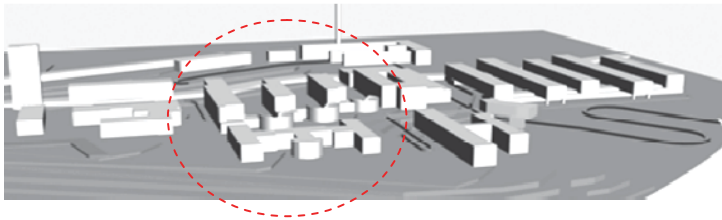

A27

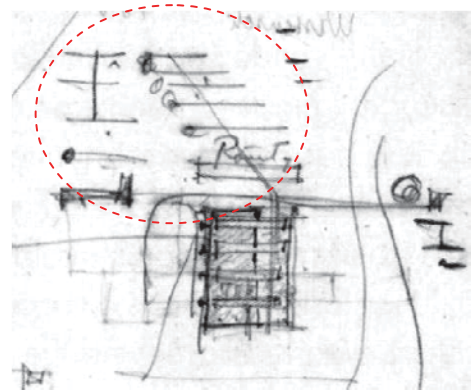

A29

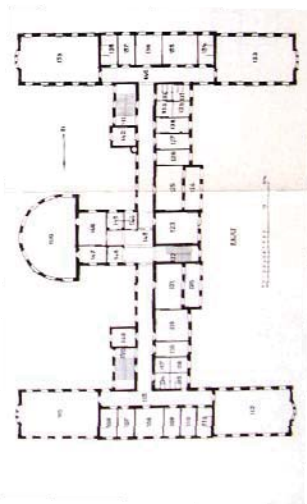

A28

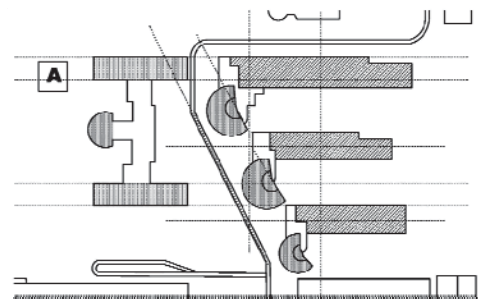

A30

A31a,b

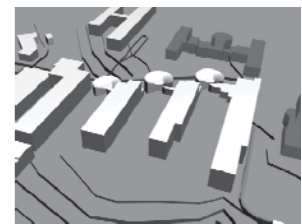
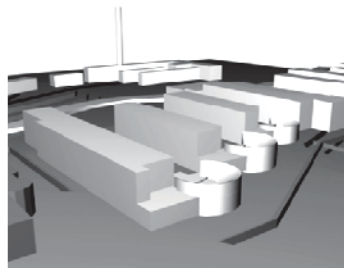

FIG A26a – Google Earth, two existing clinic building on the site, source: Google Earth

FIG A26b - Photo of the annex of the existing Pediatric clinic (1921)

FIG A27-3d composition HCZ Aalto, competition entry. (position of the three clinics with the amphitheatres behind the Old Clinic with semicircle annexed facing the center of the city.

FIG A28 - Floor plan of the, source: Zagrabska, City Library of Zagreb Sveučilište Kraljevine Srba, Hrvata i Slovenaca u Zagrebu : 1874-1924 : spomenica Akademičnoga senata. U Zagrebu : Tisak Zaklade tiskare Narodnih novina, 1925. FIG A29 –Aalto's sketch, where he incl. the old existing Pediatric clinic (1921), as REFERENCE for the composition with semicircular amphitheatre behind this clinic., source: AAA

A32



School of Medicine: Dermatology, Pediatric and Otorhinolaryngology Clinic, featuring the neo-classical elements⁴. This building is located next to the northern part of the building in the site plan of the competition (lot 1), where Aalto develops three new clinics, each one with its auditorium (amphitheatre). Aalto includes this old building when he started to develop new composition of the clinics behind (Fig A29,30). The old building main facade, is viewed as the first building on the hill from the city centre with the first viewed the semicircular two-story annex, placed on the lower ground level in the front of the three amphitheatres of Aalto's three new clinics on the north part of the Zagreb hospital complex.(Fig A31-32) Aalto created very similar forms of the lecture halls of the new clinics situated on the elevated ground level, due to a uniform dialectic context that is featured in a view from the city center to the "Salata" hill or "crown of the city",⁵ as denominated by Aalto. In the competition program is clearly given that the lecture halls have to be planned connected with the Clinics but having independent entrances, and to be designed in the form of an amphitheater.⁶ (Fig A33) This competition program requirement is also important to understand the Aalto's allegorical interpretation of the original form of the classical amphitheatre *Cavea* as the one of the inspirations sparks in connection to the local context of the existing old building.

With these two important sources of inspiration for the development of the composition of the two elements of the different nature, Aalto could make one rigid "classic" symmetric composition of the rectangular "body" and semi-circular "head", and that can be learned from his first sketches, but by the inclusion of the **other influences he has modified this early composition and made one characteristic "organic" composition "in the movement"** due to :

- c. The climatic condition (wind protection from the S-W and the best indirect insolation of the Lecture Halls by the upper sidelight)
- d. The view from the old city center, fortification around the old center gothic cathedral (with the composition of the rectangular wall and the small corner,towers of the fortification), he possibly wanted to make the dialogue with the both "fortifications" of the hill and the old city center. (Fig A34)

⁴About some influence of the existing building in this project of Aalto is mentioned by Laslo A. (2004)

⁵Aalto in his publications in Arkkitheti, 1932 described this complex as Acropolis and "crown of the city"

⁶More information in the original program of the competition

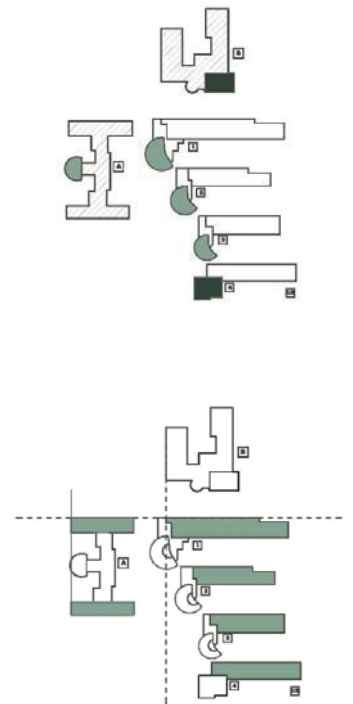

A32 b

FIG A30. Own re-elaboration of the composition of the three clinics behind the existing Pediatric clinic with semi-circle annex of the main façade

FIG A31a,b -3d model, three clinics with the amphitheatre-lecture halls

FIG A32 - 3d model complex composition. – The first building with semi-circular annex is old clinic , existing on the site

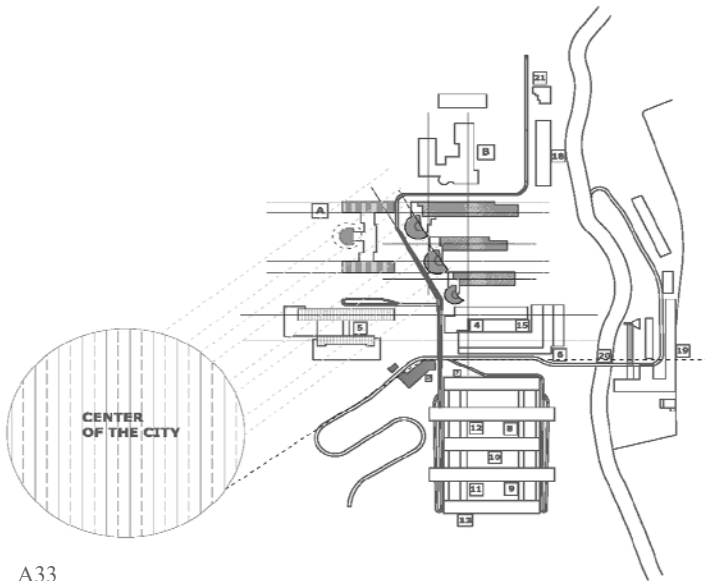

A33



A34



A35

FIG A33-Scheme, View from the city center
FIG A34 –Fortification around the cathedral , the old center of Zagreb

FIG A35 – Cover page, Photos from the book : "Zagreb in past and present 1093-1930", S.Srkulj (Mayor of Zagreb).This book had all participants, (Laslo,2004), of the competition and on this way together with all description of program and plans could be viewed main architecture from the plans and photos of the main existing buildings built until 1930. (On this first photo we can see some pages of this book and one photo of the cathedral with the small round towers of the wall around the gothic cathedral and Zagreb old city center.Source:Srkulj,1930(City Library of Ljubljana)

FIG A36 – Scheme of the map of the 3 lots of the Salata hill, site of the new complex and the climatic conditions (orientation, insolation, winds of the zone).This information is very important for the creation of the principle ideas of of the compositions and forms of this main principles from the Aalto 's competition entry for Zagreb hospital complex.

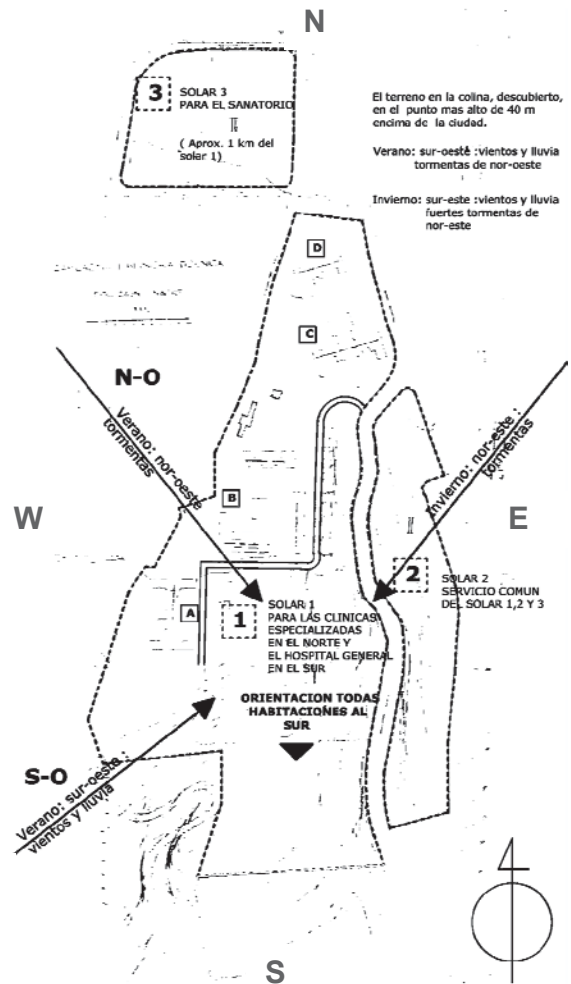

A36

For both of these reasons (c. and d.) Aalto rotated the main axis of the Lecture Hall-Amphitheatre to the S-W, to face towards the old city center. After first early sketches of trapezoidal form of the acoustic lecture hall, he developed the other form of the lecture hall as the elementary form of $\frac{1}{2}$ of the circle of the auditorium. In the half-circle shape the issue is the positioning of the all necessary spaces of the auditorium and entrance behind the stage area. Also a problem of this form is the orientation of the main rounded facade and the favorable sidelight of the lecture hall which was West-oriented.

The moment of the **Bio-Mechanic Movement** of the composition, extensions and the rotation of the previous semicircle amphitheatre) was conditioned by:

Climatic conditions (Insolation and wind protection)

Aalto aim was to ensure the best orientation of the insolation and protection from strong winds (S-W) on the hill (Fig A36)(the amphitheatre and with them to protect the clinic), and on the other side to extend the semicircle form to almost $\frac{3}{4}$ of the circle where he could organize the necessary stage's areas, rooms and entrances. He found the best sources of daylight from the S-W source for the lecture hall and for the stage the central skylight oriented to E.

This is the one of the main reasons because Aalto has **rotated the amphitheatre** of the composition towards the South- West and on this way **he broke the symmetry** and created the **asymmetric position of the "head" of the composition—amphitheatre** with the sensation of the bio-dynamic movement of the organic composition, very recognizable in many of his future projects (Fig. A37-38). By rotating the half-circle in the direction of the rectangular building of the clinic on the ground floor he forms in the same time a small protected courtyard as a physical (wind barrier) and visual protection of the space between the auditorium and the clinic. (Fig A39-40).

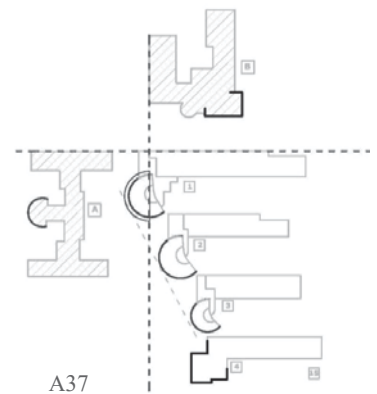

A37

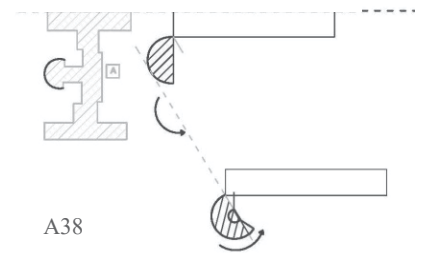

A38

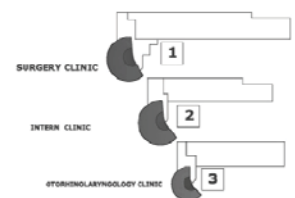

A39

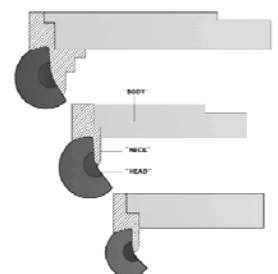

A40

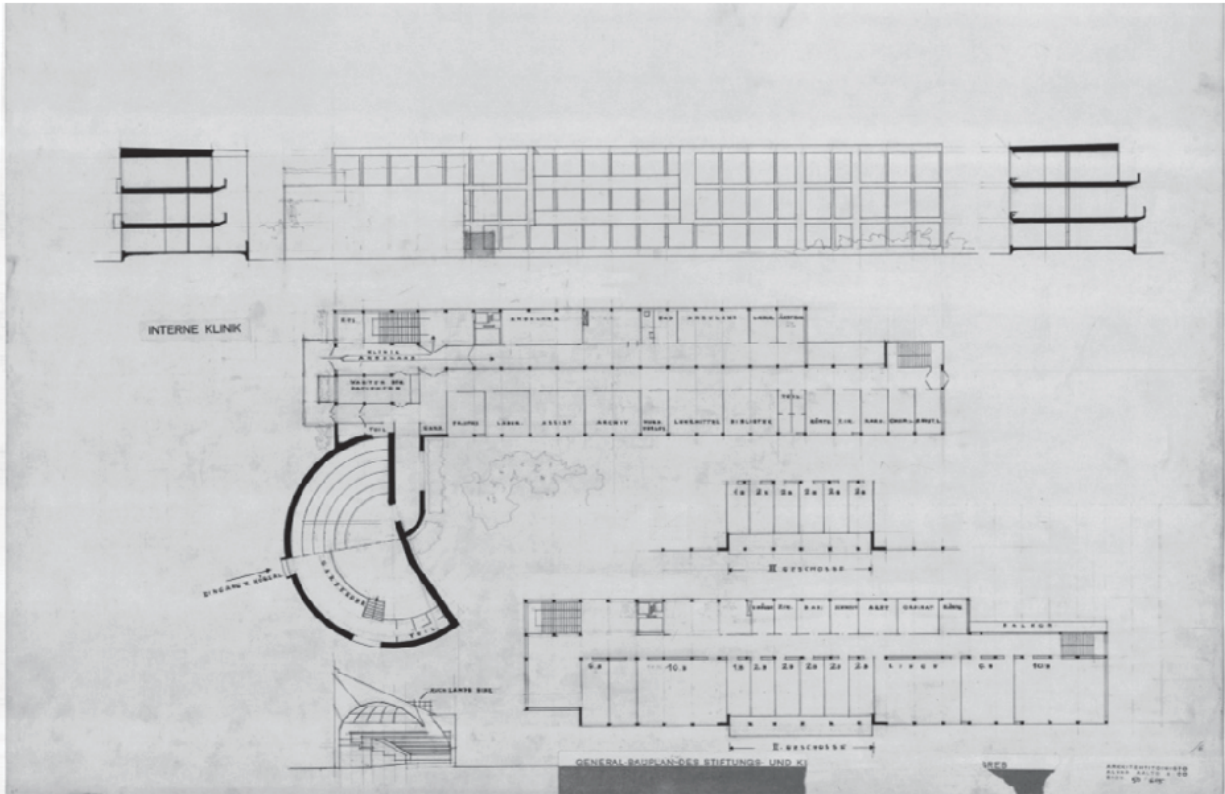

A41

FIG A37-39 – Rotation of the amphitheatre and extension from $\frac{1}{2}$ to $\frac{3}{4}$ of the circle – base

FIG A41 – Final drawing of the Internal Clinic for the Competition entry of Hospital complex of Zagreb,(1930) , Aalto 50/615 (AAA)

FIG A42 – Drawing of the section floor of the Amphitheatre Lecture Hall of the Clinic of the competition entry of Zagreb, AAA, (**FIG A42a** -analysis of author)

FIG A43 - Drawing of the the ground floor of the Amphitheatre Lecture Hall of the Clinic of the competition entry of Zagreb,



A42

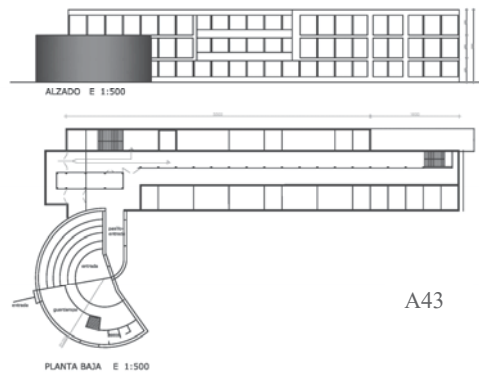
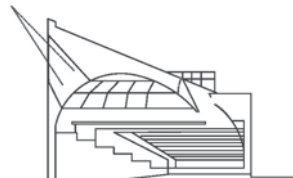

A43

The dialectic image of a "whole complex" viewed from the city

Aalto forms the uniform dialectic view from the city center of Zagreb, which is located in the south-west of the complex. The fortifications around the cathedral in the center also feature the small circular towers that are in dialogue with the similar forms in view of the "Crown of the city". Aalto could see and analyze these images of the context from the City guide of Zagreb⁷, which was sent to all competition participants with some photos and descriptions of the main emblematic buildings and sites of the city. One of the goals was to ensure the privacy and comfort in different functional zones for the different users of the complex: patients, staff and students of the School of Medicine.

The amphitheatre is a form generated by a section rotation with respect to the guideline of the floor plan. This form of the concave roof of the School of Medicine lecture hall Aalto was developed with more curvatures than in his famous Lecture Hall of the Aalto's University of the campus in Otaniemi (1949-66).

In this project of the lecture halls - amphitheatres of the three clinics of Zagreb, he created a distinctive orthogonal side façade and the triangular section, which together give along the circular path a concave external form of the roof of the auditorium. In the early drawings of the lecture hall in Otaniemi main University building competition in 1949 Aalto implemented one analog form of the orthogonal vertical side of the lecture hall - amphitheatre façade and triangular section. However, to eliminate the complexity of the concave roof (appearing in Zagreb clinic's lecture hall) he "cut" this form of previous $\frac{3}{4}$ of circle and formed in Otaniemi Lecture Hall the basis of $\frac{1}{4}$ of the circle in the form of the amphitheatre. Using this approach, the same triangular form of the section and side facades is obtained. Aalto also experimented with the $\frac{1}{4}$ of the circle in his first versions of the amphitheatre of the Lecture Halls for HCZ competition, where he planned the amphitheatre ($\frac{1}{4}$ of the circle) coming out from the rectangular base.

e. Competition program required design of the one interior hall entrance from the clinic to the lecture halls of the University of Medicine, and also required design for some clinic annexed spaces, as the operation rooms next to the Surgery clinic lecture hall.

⁷ Laslo, 2004, p 110-131

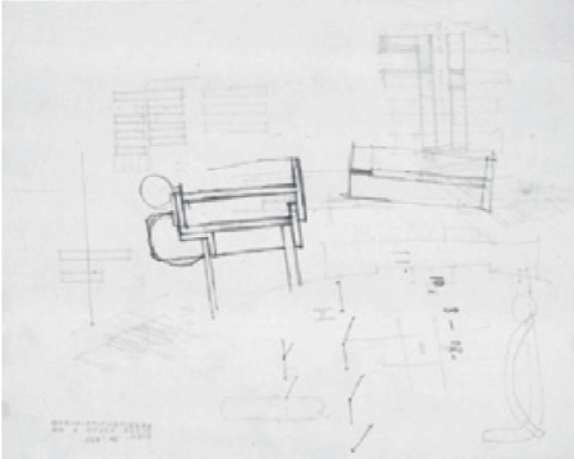

A44

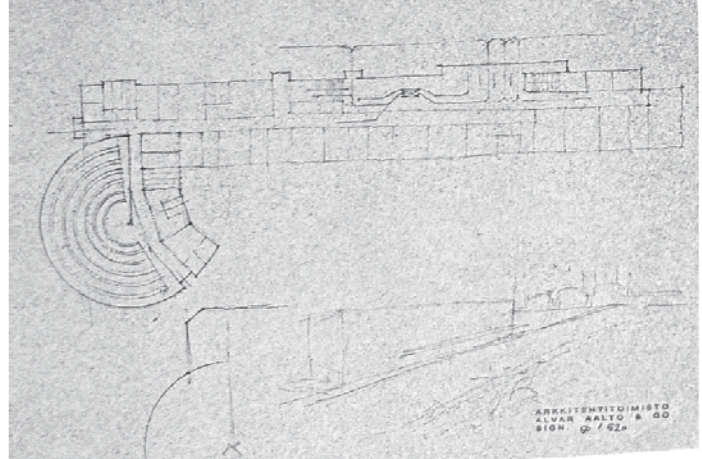

A45

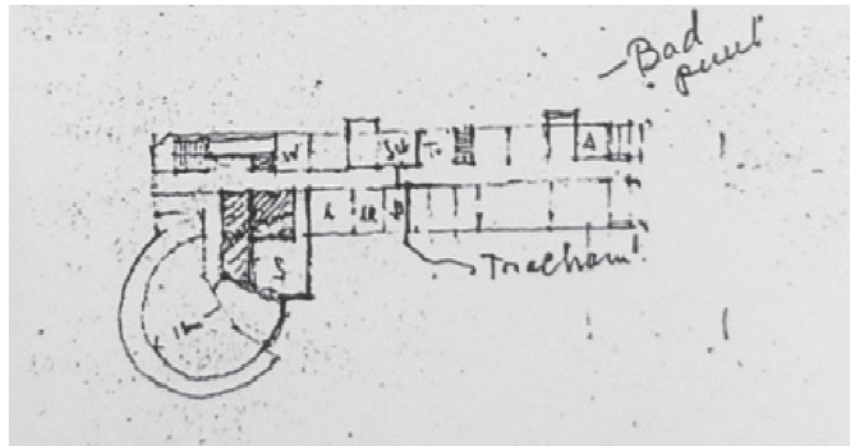

A46

FIG A44 - On the other side of the paper of the drawings for the competition entry of Zagreb we can find one interesting drawing of the detail of the new system of windows which Aalto developed at the same time of this competition. On this competition he applied new system of windows sloping upside (as confirm Goran Schildt too in the "Aalto: The Decisive Years", Rizzoli 1986), source: AAA

FIG A45 -Early sketch of the Clinics, composition with auditorium, Schildt, 1994a, AAA

FIG A46 - Early sketch of the Clinics, composition with auditorium, AAA

FIG A47 - Internal Medicine clinics, ground floor

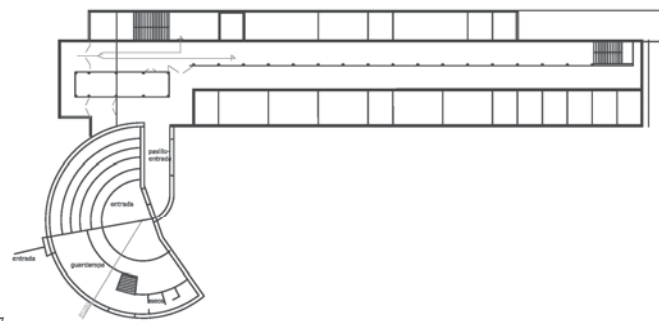

A47

For that functional necessary annexed spaces Aalto made the "extension" of the semi-circular base to the base of $\frac{3}{4}$ of the circle (which different proportion will be used as the *amphitheatre motif* along all his creative trajectory), Goran Schildt also confirmed that Aalto on this project of the HCZ developed a new system of the "upward slanting window system".⁸ (Fig A44. Moreover, we could believe that this technical details of the project also could have taken some part in the subconscious base of the inspiration to create the new "mobile" architectural composition of the new clinics of Zagreb with the semicircular auditorium as "window hinge" and window frame as the rectangular part of the composition, clinic building.

These architectural elements will become "leitmotifs" of the Aalto's architectural "own" organic language, which he started to form in 1929/30, where he participated on many unrealized competitions, at the same time with this project of HCZ, where also all his projects from the beginning show us that his language was based on the elementary forms. Observing the plans of the amphitheatre of this competition and other similar compositions (e.g. many libraries as in Rovaniemi, Oregon, Seinäjoki), are observed the "bio-mechanic mobile" connections between the amphitheatres and the "frame"- rectangular body of the composition, all as one bio-mechanical-organism.

He used this principle of the composition "head and body" in the bio-mechanical movement, as the **fusion of the organic and mechanic process** in many of his buildings of education, culture, religion, health, and others. The "head" of the composition as the "mobile" element which "representing" and rectangular "body" as the "static" component which "organizing" and gives balance.

That is clearly observed in the floor plans of the many of his culture centers, churches, libraries in Rovaniemi, Oregon, Seinäjoki, House of Culture in Helsinki and his analogous composition of the main Otaniemi University building. In the future variations, these compositions, based on the circular heads of the composition, often "rotate" until $\frac{1}{4}$ of the circle to the rectangular body of the composition (as in the case of Seinäjoki, Rovaniemi or Oregon Library). (Fig A48-52)

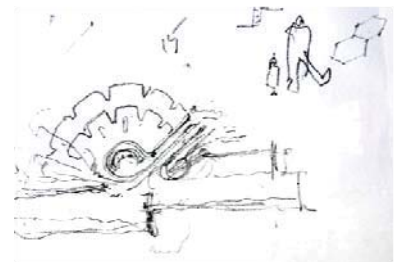
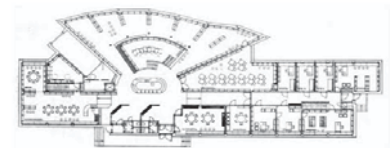
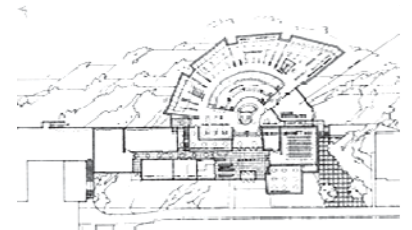

A48-A52

⁸ Schildt G, "Aalto, *The complete catalogue of Architecture, design and art*", Rizzoli, 1994, p.

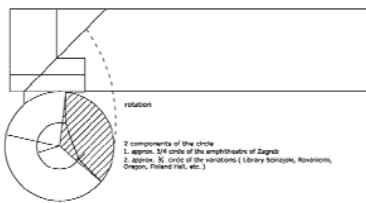

A53a

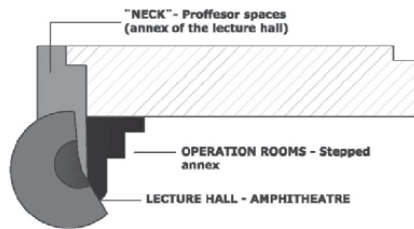

A53b

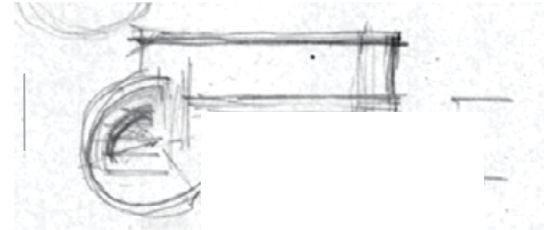

A56

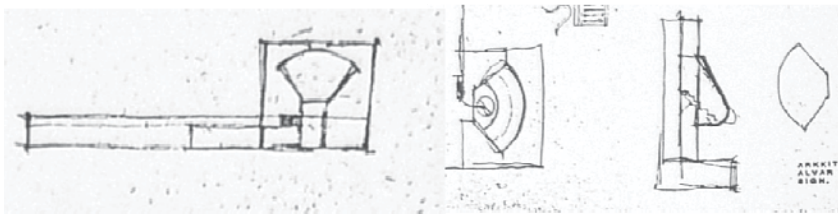

A54

A55

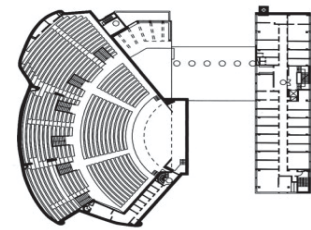

A57

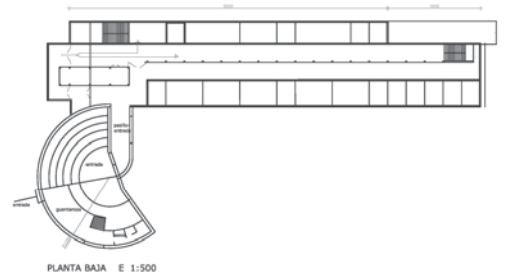

A58

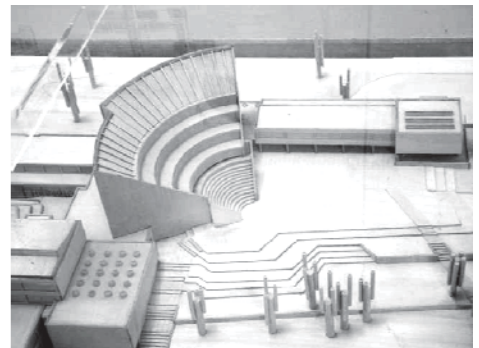

A59

FIG A48-52 – Library Mont Angel, Oregon; Library Seinäjoki; Library Rovaniemi sketch; Library Rovaniemi drawing, floor plan, AAA

FIG A53a- analysis of the composition and the $\frac{3}{4}$ segment of the circle of the amphitheatre and rotation - "bio-mechanic" composition in movement,

FIG A53b – scheme of the Surgery clinic, head+neck+body (annexed steeped operation rooms)

FIG A54 – first version of the composition and wedge-shaped amphitheatre, (other segment, proportion which he use on almost all auditoriums, amphitheatres of approx. $\frac{1}{4}$ circle)

FIG A55 – sketch , rotation of the $\frac{1}{4}$ of circle. Mount Angel, Oregon, Aalto , source: AAA

FIG A56 – Sketch of the clinics of the composition of the "two elements of different nature" of Clinic of Zagreb (1930), Aalto, source: AAA

FIG A57 – House of Culture, Helsinki, Aalto (composition head and body)

FIG A58 - composition of the "two elements of different nature" of Clinic of Zagreb (1930), Aalto

That part of $\frac{1}{4}$ circles is the form of the first version of the lecture hall of the clinics of the HCZ competition, and derivation and complementary segment of the $\frac{3}{4}$ circle is the final version of the amphitheatre of Zagreb clinics., where together, both segments complementary form the "whole"- circle.(Fig A53a,b,54)

The function of the Head - Lecture hall-Amphitheater and Body-Clinic. "Head" as the "representative" component and "Body" as the "organizational" component

Aalto planned two entrances of the lecture halls of the University Clinic of the HCZ competition entry. The first one as an outdoor main independent entrance for students, which he located in the lecture hall, under the bleachers of an amphitheater, wardrobe and toilets. The other one, as an interior entrance through the hallway, as the connector in the ground plan with the rectangular main building of the clinic for the medicine teachers, where he organized their necessities spaces.

Other independent entrances for the patients and the staff of the clinics he planned directly on the facades of the rectangular buildings of clinics next to the main access paths of the complex. The convex shape of classroom roofs was developed on the different higher levels of the facade because of function, noise, insolation, ventilation, acoustic properties and the views inside the lecture hall. Aalto approached the highest level of the facade of the main student entrance where he organized all necessary spaces under the bleachers and lower spaces of the stage for the hallway space. Connecting these two planes of the facade of different heights Aalto created a convex interior "cupola" of the curved beams and at the same time concave roof of the amphitheater. For the acoustic reason, he created a curved cupola consisting of beams and above them, he provided daylight arriving through the conic space and the upper side windows. This system of upper windows next to the roof of the amphitheaters, Aalto used in many auditoriums after this project, as in the case of the "cupola" created by the beams of the lecture hall of the University of Otaniemi, where he formed the stepped ceiling light, and in the case of HCZ he developed the upper sidelight source and one stepped skylight above the stage.



A60

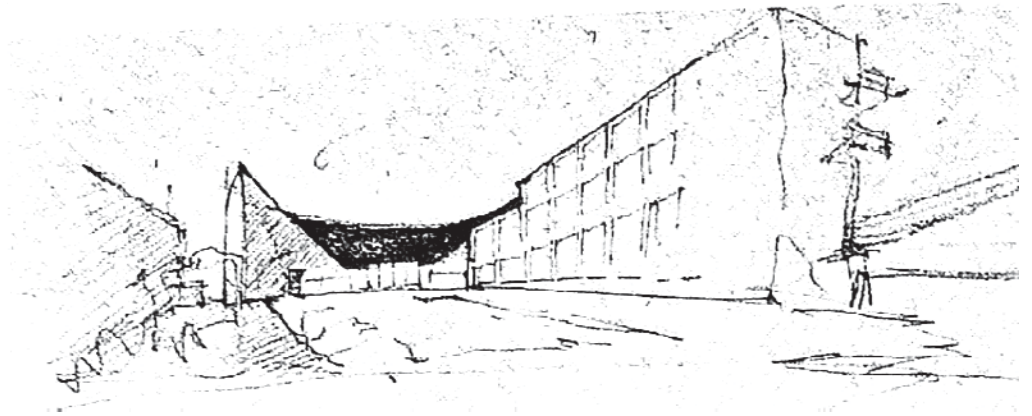

A61

FIG A60-Perspective sketch of the amphitheatre of the Aalto's University in Otaniemi, Aalto, 1949-1966, Schildt, AAA

FIG A61-Perspective sketch of the composition of the Clinic in the north of the hospital complex of Zagreb competition entry, Aalto, 1930/31, AAA

FIG A62-Photo montage(mirror) author: Photo of the composition "Variat" "Heonsad and Body" and Amphitheatre "Lecture Hall", Amphitheatre of the Aalto's University in Otaniemi, Aalto, 1949-1966



A62

Aalto on the start of his career used the same strategies rooted in the logic of an application for the specific use and context. After this project, it is observed that he also applied these analogous forms for other uses and contexts in his future projects, later analyzed in the study. This can be deduced as a final products of a process based on interactive memory and self-feeding during his trajectory, always thinking about the best use of the element in a given case. Aalto told that is not possible one Acropolis in Helsinki but everything that existed re-born, and that is found in many of his auditorium-amphitheatre buildings, designed for different uses: educational, cultural, religious or administrative function. He used this form and variations at the auditorium in Otaniemi, Finland Hall, House of Culture, many of his libraries in Seinäjoki, Rovaniemi, Oregon, Wolfsburg culture center and many others his well-known works, and on his performed works Aalto gives life to these new ideas, born in the project in Zagreb and for that reason, it is important this analysis of the origin, genesis and evolution of all new elements and principles which he implemented frequently during his trajectory.

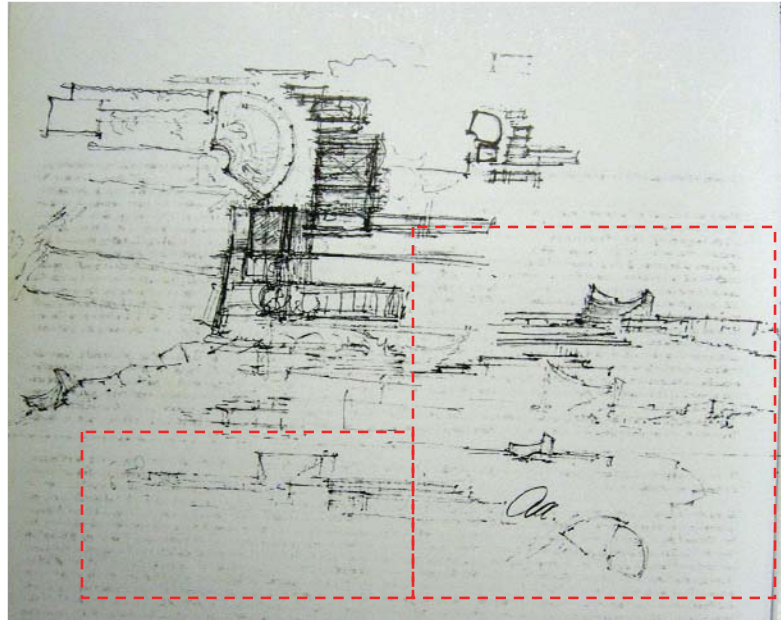

A63

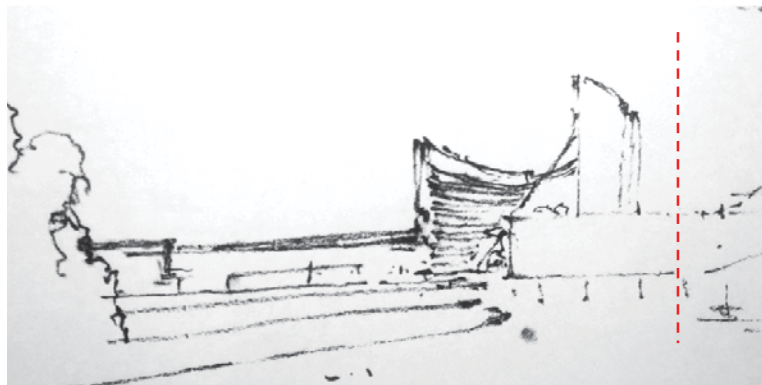

A64

FIG A63, A64 – Early sketches of the composition of the Lecture Hall of the University of Technology in Otaniemi, with the different proportions and forms of the amphitheatre. (different segmentation of the circle base and the relation between the section and the façade, where it can observe that on the first early sketches of the Lecture Hall in Otaniemi Aalto applied the similar proportion with the perpendicular line of the façade and triangular form of the front façade, after he was changed the proportion, to simplify the concave form of the roof with the base of approx. $\frac{1}{4}$ of circle), source: AAA

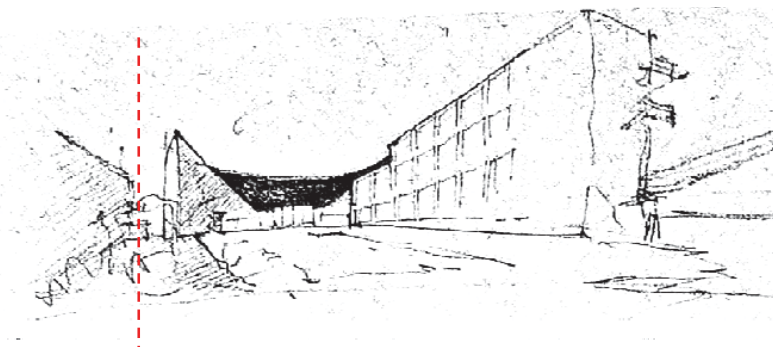

A65

FIG A65 – Perspective sketch of of the Amphitheatre Lecture Hall of the Clinic of the competition entry of Zagreb, Aalto, source: AAA

Amphitheatre of the School of Medicine of Zagreb Vs Amphitheatre of the University of Otaniemi (Aalto University)

Almost 20 years after this competition project for the HCZ with the School of Medicine (1930), Aalto developed the very similar form of the main building of the University of Technology of Helsinki in Otaniemi (1949-1966). We are surprised with a very similar composition between these two forms and the very resembling form of the Classical Amphitheater.⁹ (Fig A60-62)

The Lecture Hall of Otaniemi was influenced directly by the HCZ project. The application of this solution is present as the auditorium - amphitheater with all structural and visual characteristics with the same structure that influenced the way reflecting the acoustic and organic character in movement simultaneously. In 1949 Aalto's first wife died, Aino Aalto, who collaborated on almost all projects (although her contribution of new ideas in the projects cannot be easily separated from Aalto's ideas). In this competition project we can find her signature appearing in several drawings, which confirm that she also collaborated on the creation of the new ideas of HCZ competition. All details of the Aalto's biography are important to explain the rebirth of the idea of the concept of the "Amphitheater" of the lecture hall. He used the same concept of the composition of pavilions as a body "backbone"(Fig A71a,b), which we observe twenty years later in the project on the campus of the University of Otaniemi, featuring the strong ideological connection between both projects.¹⁰ A year before the death of Aino, the University of Technology of Helsinki announced the competition for the whole area of Otaniemi in the year 1949. Several months after the death of his wife, Aalto project was delivered and we can assume that they started together to form the ideas for this first project and that they developed together the main building of the campus. Knowing that Aalto was president of the Association of the Finnish Architects (from 1942), and after the Russo-Finnish war, since 1944, he was realized some urban renewal project, probably had a priory information,

⁹ From the Previous Notes of this thesis where is written some sources where are mentioned the new element-ampitheatre of this project (Schildt (1986), Quantrill(1983), Radovic (1995,1997), Hrausky(1997), Norvasuo(2006),Laaksonen(2009)

¹⁰ (New principle of "Backbone" will be explain in the part of the Analysis of the 2.Zone of the Foundation Hospital.of the Hospital Complex of Zagreb competition entry).

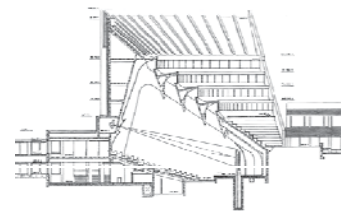

A66

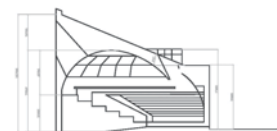

SECCIÓN 1-1 ANFITETRO - ALLA ACÚSTICA DE LA CLÍNICA INTERNA E 1:250

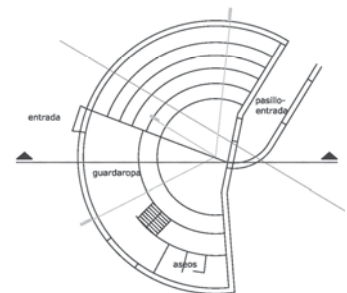

A67

FIG A66– Section of the Amphitheatre of the Polytechnic School of Otaniemi, Aalto, 1949-1962

FIG A67– Sketch of perspective of the composition of Clinic of north of hospital complex competition entry, Aalto, 1930/31,

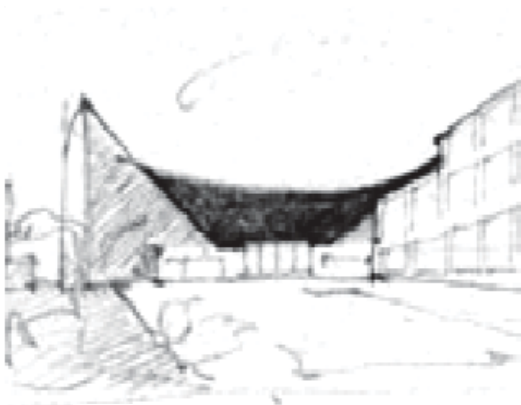

A68



A71

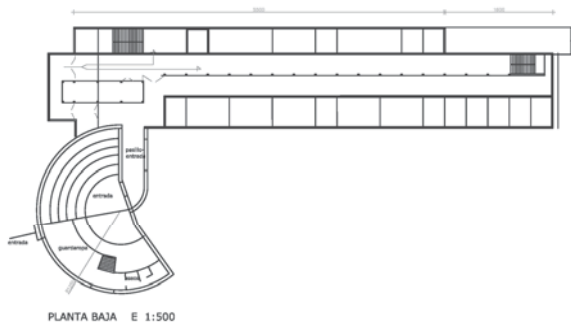

A69

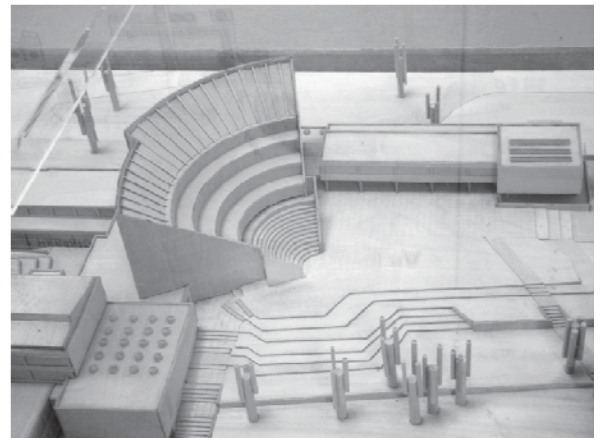

A71a

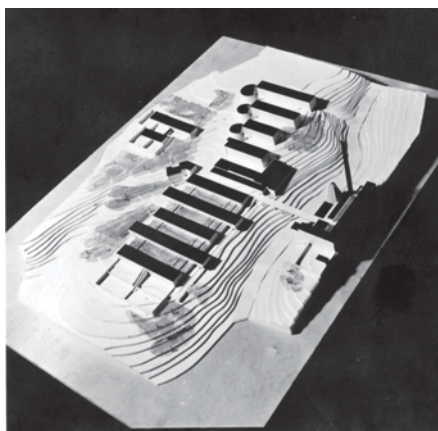

A70

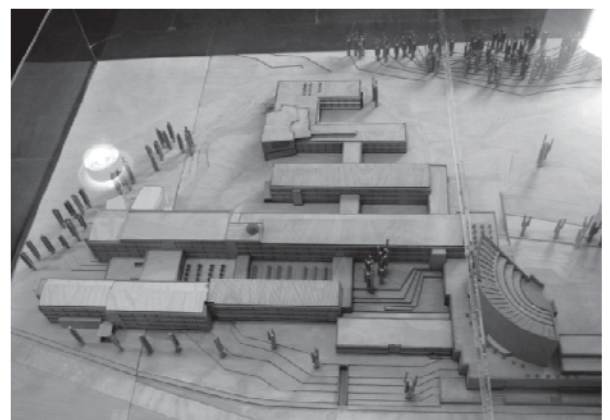

A72

long before the published competition (in 1949), that the Polytechnic University of Helsinki will be needed to move, which allowed him to substantially include Aino to develop together some main ideas from the HCZ project, (before her death in 1949). Analysis of the University of Otaniemi project reveals that the main building of the Campus in Otaniemi contains one collage of ideas - new principles previously implemented at the Clinics of the School of Medicine in the HCZ competition entry, which included ideas of both: Aino and Alvar Aalto.

Aalto being in a difficult moment, two months after the death of his wife, tirelessly worked on this famous project using the design process based on associations and memories. The main idea of auditorium as the classical *Amphitheatre* of this project as a "*Sacred Temple*" (Fig A73) is a clearly a rebirth of the lecture hall of HCZ from a joint effort of Aino and Alvar Aalto of Zagreb competition entry. Simultaneously, he created the similar composition of the "head and body" with the main static rectangular building and the connected round form "in the movement" of the lecture hall.

Implementing the sixth principle, formed during the Zagreb competition, Aalto approached the design of universities pavilions buildings of Otaniemi. They constitute the parallel system of individual rectangular buildings, which are represented as "vertebrae" of the "backbone", analogous to the compositional structure of the seven departments of the Foundation Hospital of the Zagreb competition entry. In the case of the lecture hall of Otaniemi he designed the amphitheatre basis as $\frac{1}{4}$ of circle (and in the case of Zagreb it is almost $\frac{3}{4}$ of the circle basis). Due to this proportion, he considered a bigger rectangular basis, with the stepped horizontal plane on the ground floor around this form of the amphitheatre, where he included all necessary spaces and the main entrance very similar to the annex of the Surgery Clinic in Zagreb competition entry, where he organized the surgery rooms and entrances in the stepped annex form around the lecture hall-amphitheatre.

In 1949, he developed the first urban plans of the campus in Otaniemi and the Architecture of the main buildings where Aalto applied very similar ideas of the Zagreb project. Further, he developed many projects of the majority of the different



A73

FIG A68– Drawing of the perspective of the Amphitheatre of the Clinics with the School of Medicine of Zagreb, Segment, Zagreb, Aalto, source AAA

FIG A69– Drawing of the floor plan of the intern clinic, Zagreb, Aalto, own drawing

FIG A70 – Original model of the complex "Backbone" composition Zagreb complex, Aalto, source AAA

FIG A71a,b,72,73 – Photos of the Lecture Hall- Amphitheatre of the University of Technology, Otaniemi (1949-1966)

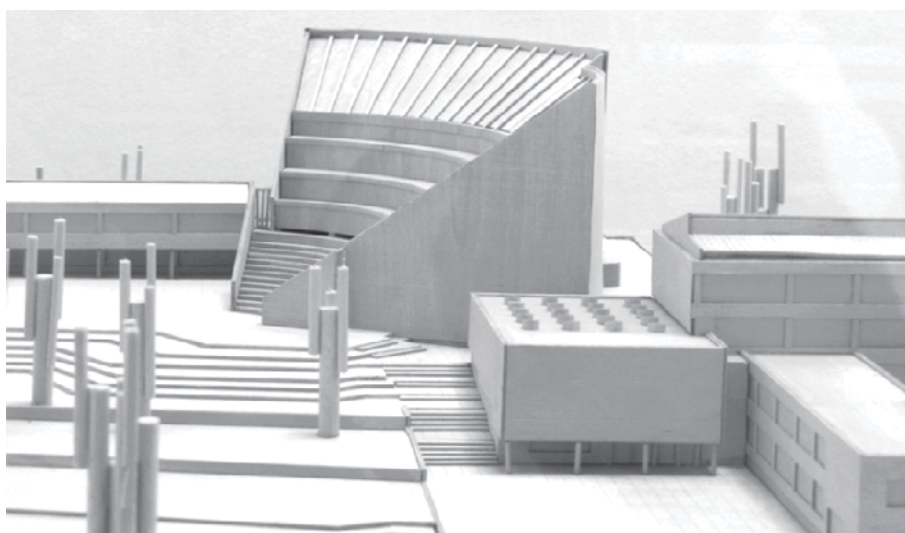

A74



A75

FIG A74 - Model of the Lecture Hall, elevation of the ground as the basis of the monumental "Sacred Temple" – Lecture Hall – Classical Amphitheatre of the University of Technology in Otaniemi, Aalto, (1949-1966)

FIG A75– Photo of the Lecture Hall, elevation of the ground as the Ancient basis of the Monumental and Sacred Temple – Lecture Hall – Classical Amphitheatre of the University of Technology in Otaniemi, Aalto, (1949-1966)

campus buildings. All campus buildings in Otaniemi were developed in Aalto's office from 1949 to 1975 (finished one year before the death of Alvar Aalto).

The use of the "amphitheater" in the composition of Otaniemi University and Zagreb university clinics, is the same in both projects as the Lecture Hall of the University, however, we observe that Aalto applied analogous ideas in different contexts of both projects, which represents the second point of analysis of our interest. In Zagreb project the terrain is naturally configured with the Amphitheatres of the three clinics on the highest point of the hill, whereas in the case of Auditorium - Amphitheatre of Otaniemi Aalto tried to reinterpret that forms and compositions and for that reason he formed an artificial stepped configuration from one plane base as the hilly terrain with stepped levels - "cascades" of the topography, forming a higher base of the Lecture Hall as the "Sacred Temple" of "Acropolis" on the hill. This strategy of elevating the composition dominant building on the "platform" by the stepped artificial configuration Aalto applied in many projects (Fig A74-75). Aalto used this method of the topographical configuration of terrain implementing the same logic of the open-air amphitheater creating the terraced sides of the hill over the one flat topography. In this way he enlightens one simple form of building with a sacred and monumental character. We can see this concept of the re-configuration of the terrain also in his studio of Munkkiniemi, Town Hall of Saynatsalo, Seinajöki, and other remarkable works. His urge of re-configuration and artificially landscaping the terrain which has an origin in "landscape" of his memory of the terraced slopes of Italian hills, and in real given Zagreb competition hilly site which he called "Acropolis", where from a number of sources of Aalto's written thoughts and his projects, we can learn that he always wanted to apply the Mediterranean landscapes to the flat topography of his native country Finland.

He repeated this compositional motif of the amphitheatre on many of his projects: cultural, educational, religious buildings and libraries as a simple monumental round form from the Ancient cultures and the classic "spirit" of the central library of Asplund in Stockholm. Analogous structure of the spatial organism in the movement (head and body) can be recognized in his Libraries in Rovaniemi, Oregon, Seinajöki buildings, Culture House of Helsinki, Finland Hall, Culture Center and Church of Wolfsburg and

many others Aalto's very known works. Here it can be find different proportions and variations of the Amphitheatre forms and the composition in the movement that Aalto adapted for different functions of the spaces (different amphitheatre spaces of the concert hall or library hall).

Aalto on many projects used at the same time two or more principles that emerged out of his Zagreb entry. The first principle of the characteristic composition "head and body"; "head" as the Amphitheatre, from the "second new principle", was also frequently used jointly with the "fourth new principle" - the repetitions of the same segments - "species", by the radial path. The synergy of both principles formed one fragmented structure "fan shape" of the auditoriums recognizable in many Aalto's projects.¹¹

At amphitheatre forms, he often applied upper windows system on the facade near the limit of the ceiling of the auditoriums to provide the indirect dispersed light, shedding inside the "cave" and in this way avoiding any nuisance in the interior. On the projects of libraries the fan-shape¹² of the "head" of the organic composition, he formed for the other reasons as well, and not for the principal acoustic reason as in the case of the concert halls, but for the best function, interior organization and to provide the best way the light of the central lecture space of the library. The amphitheatres of the libraries almost always are two levels high and follow the round shape which he often organized in the orthogonal system of the shelves with the literature and the lecture space with tables and more private spaces.

Aalto created there small individual spaces in the big central hall and masked it from the directly view. The light usually comes from the double source to the central space in his designs, upper side windows and roof skylight.¹³

¹¹ More details in the part of the Principle of the Repetition of the segments

¹² Markku Norvasuo: "*The Amphitheatre and fan-shaped forms*", ptah, 2006:2 - The theory about the Amphitheatre motive and fan shape, was also reported by Markku Norvasuo from the research center of Alvar Aalto, who stressed: *Elements of classical theatre and the fan shape frequently occur together, especially in Aalto's auditoriums design.*

¹³ This fan-shape and light in these Lecture Halls – Amphitheatres of the Zagreb competition entry and the future derivations and variations will be analyzed in the fourth and fifth new principle of this study.

Ophthalmology Clinic

PRINCIPLE 3

Rectangular Auditorium correlated with Amphitheatre
"TRANSITIONAL FORM" in the "TRANSITIONAL AREA"

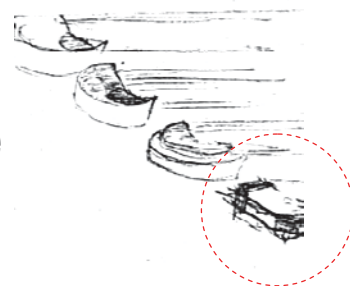

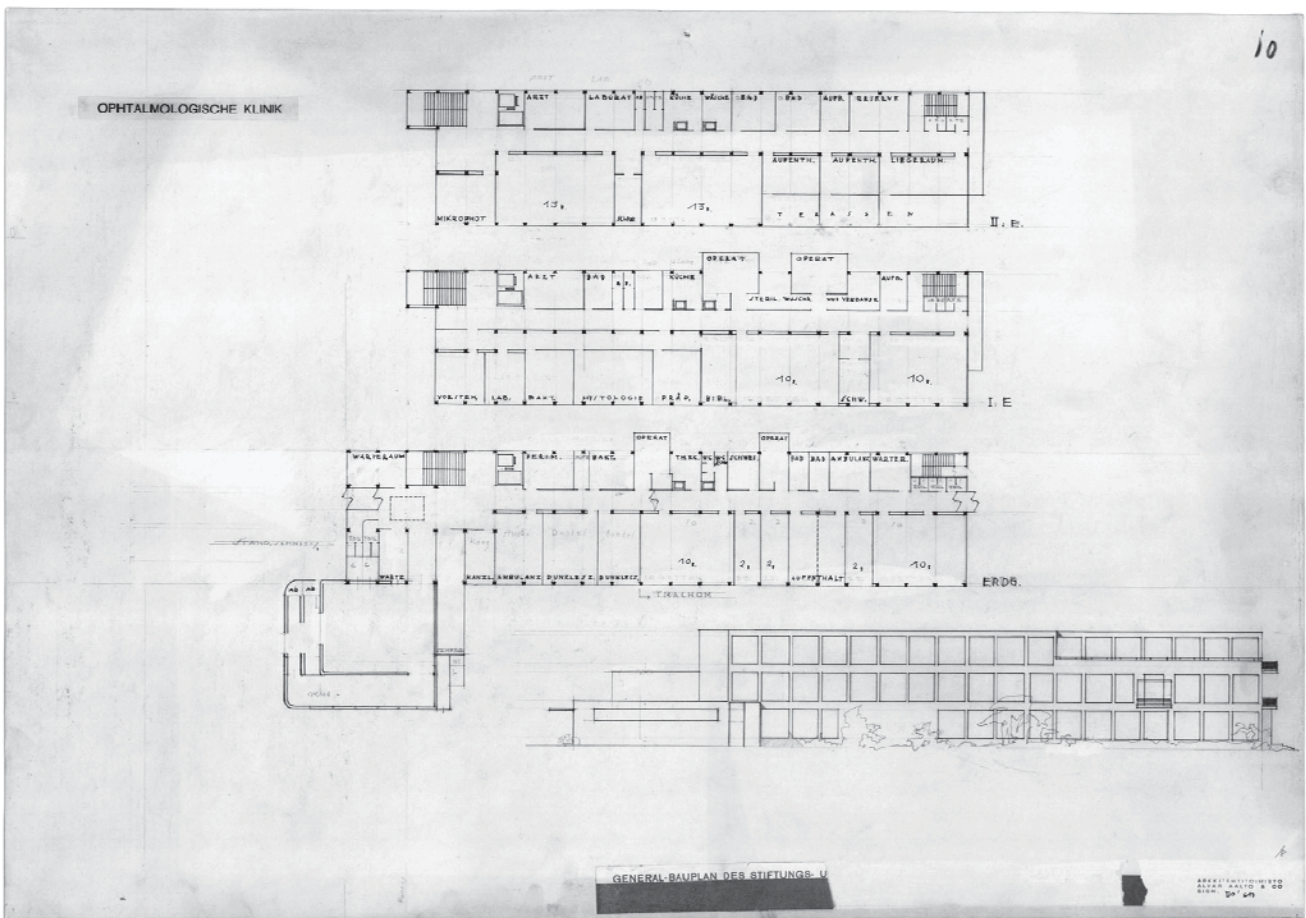
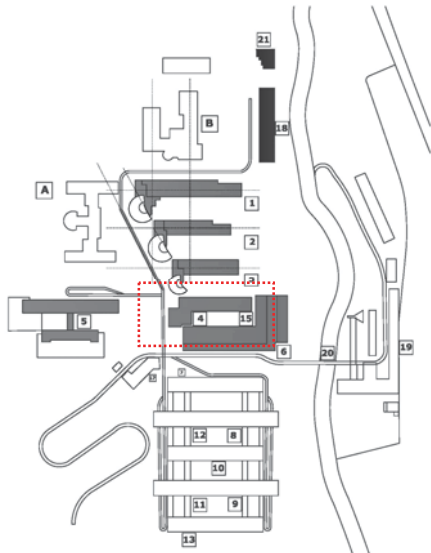
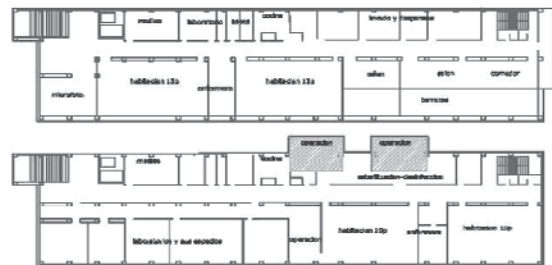
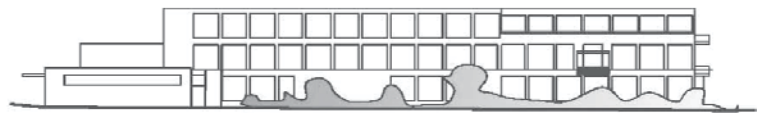
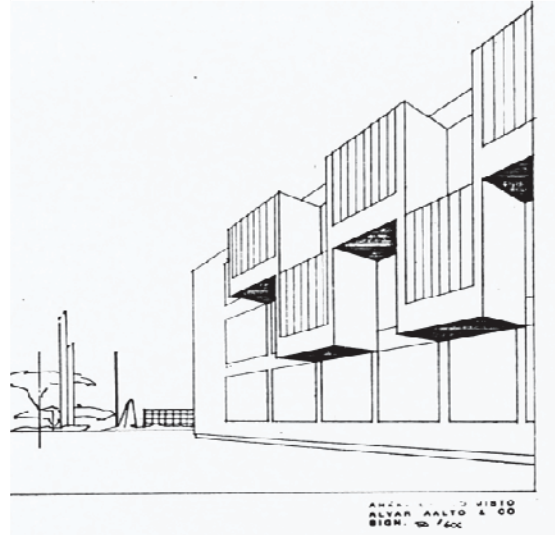

FIG 01 - Final drawings, floor plans and façade of the Ophthalmology Clinic of the Competition entry for the Hospital Complex of Zagreb(1930),50/617
source:- AAA



O2



O2a

FIG O2 – Drawing of the optional façade (with extensions, operations rooms-console) of the Ophthalmological Clinic of the Competition entry for the Hospital Complex of Zagreb, source: 50/606, AAA

FIG O2a - Clinic of Ophthalmology of the hospital complex of the Aalto's proposal

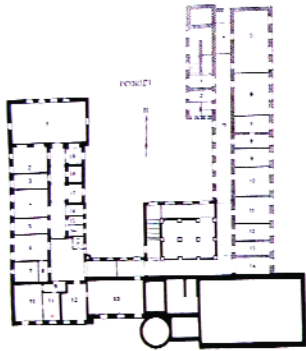

O3

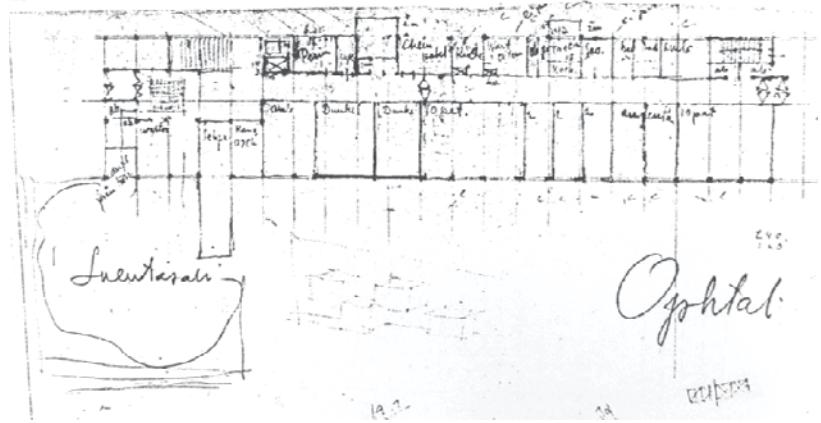

O4a

FIG O3 - floor plan of Dean of the Medical University, Institute Morphological - Biological and Physiological, Architects I. Fisher and F.Grabic, 1917-1919 (Salata 3), source: collection, source: "Zagrabiensia" from the City Library of Zagreb (Gradske knjižnice u Zagrebu), Sveučilište Kraljevine Srba, Hrvata i Slovenaca u Zagrebu: 1874-1924: spomenica Akademičnoga senata. U Zagrebu: Tisak Zaklade tiskare Narodnih novina, 1925.

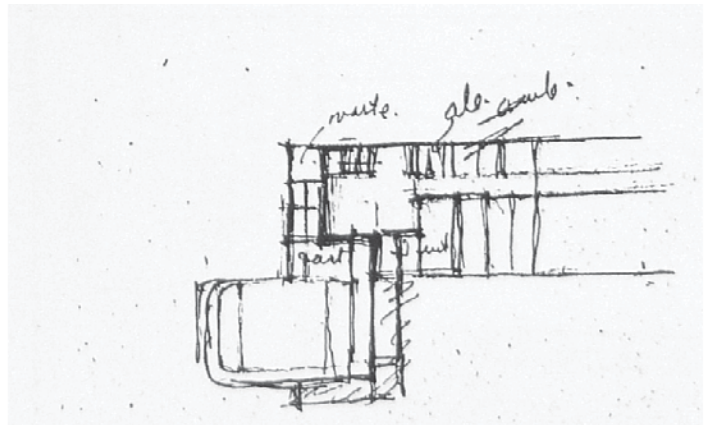

O4b

FIG O4a - Aalto's sketches of the Lecture Hall of the Ophthalmology clinic of the north of the hospital complex, we can see how he first, on the Fig O4a searching for one "TRANSITIONAL FORM" between round forms of the auditorium on the north and the rectangular form on the other sides. On the sketch **FIG O4b** - it's observed the form of rectangular auditorium with rounded corners. He developed this rectangular form where the competition program required northern orientation of the sidelight of this lecture hall (difference of the other three clinic - where program required classical amphitheater lecture halls of the University of Medicine), connected with the rectangular part of clinic and organized space with independent entrance, its very small angle of inclination of the floor of this lecture hall, only 40 cm (that come also from the requirements of the competition program) source: 50/541, AAA

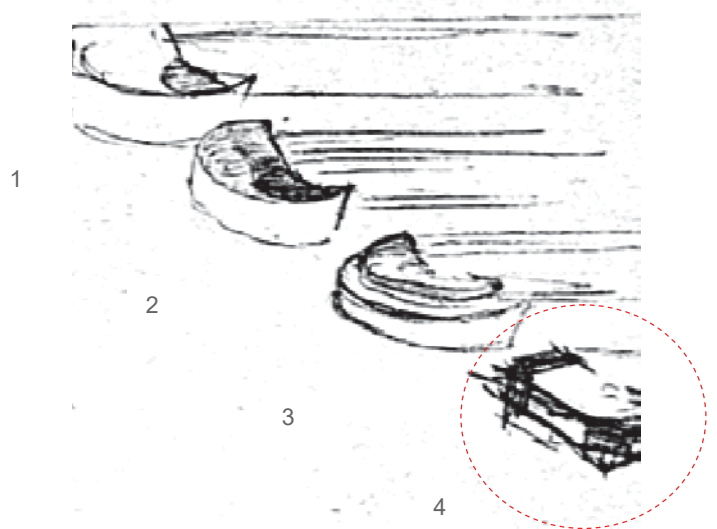

O5

FIG O5- Fragment of the Aalto's sketch of the perspective 3-d of the four clinics auditoriums - lecture halls of the north of the complex, Aalto's sought for the form of the forth lecture hall of the Ophthalmology clinic to make dialectic image between the amphitheatres and the other part of the complex as the "TRANSITIONAL FORM" (on the south part of the General Hospital) and Center of Radiology and Physiotherapy with rectangular conception and on the North circular amphitheatres of the three clinics (numeration 1-4 amphitheatres)

For the Ophthalmology clinic of the hospital complex, Aalto developed a square auditorium on the corner of the rectangular form of the clinic, which is recognized in many of his future projects. (Fig 01-04)

Aalto created the rectangular annexed lecture hall as required in the program and due to the context of the competition, where this lecture hall needed the north source of sidelight (competition program). By applying the same system of the amphitheatres of the other three clinics, next to the rectangular building of the clinic, he was unable to provide the north daylight to this lecture hall. For this reason, he developed this kind of the lecture hall of the Ophthalmology clinic, where the program required a slightly sloped floor level of this lecture hall, with a difference between the floor levels of maximum 40 cm of approx. 10 m large lecture hall. The program required two independence entrances: one entrance from the hall of the clinic and the other independent entrance for this lecture hall of Ophthalmology.

After these requirements of the program of the competition, Aalto decided to make the rectangular form of the lecture hall of this clinic to obtain the best organization of space. The rectangular "head" of the composition Aalto used prior to HCZ, but here we observe developed one very characteristic rectangular auditorium form with the "trimmed"- rounded corners. (Fig 05) By analyzing the context of the complex, we can rightfully assume that it could make this form,also,to establish the direct dialogue with the existing built context with the old clinics. In this way, Aalto possible re-interpreted the rectangular annex on the corner of the floor plan of the existing old clinic building of Dean of the Medical University, Morphological - Biological and Physiological Institute, Architects I. Fisher and F.Gabric,1917-1919, next to the north lot of the new complex (Fig 03, Fig 06).

Another reason of trimmed, rounded corners of the rectangular auditorium can be found in the Aalto's desire to establish the dialogue with the other three lecture halls of the north part of the complex and their circular shapes of the amphitheatres (Fig 05, 06).

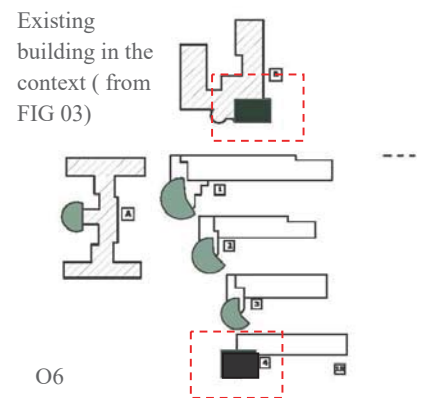
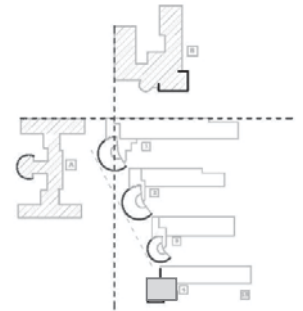

FIG 06 - analysis of the composition with all clinics and their lecture halls of the University of Medicine of the north part of the complex. Aalto wanted to make one dialogic composition with the existing old clinics next to this north part of the complex. These old clinics have the classical composition which Aalto developed on his "bio-dynamic" way. First reference of the old existing clinics with rectangular and semicircular annexes.



O7a

FIG O7a – Scheme of the ground floor of the Ophthalmology clinic

FIG O7b –Aalto’s early sketch, composition of the first version of the Ophthalmology clinic, perspective sketches 3-d of the four auditoriums and on the bottom of the paper one early sketch of the view from the city on the Salata hill, competition entry of Zagreb, 50/490, source: AAA

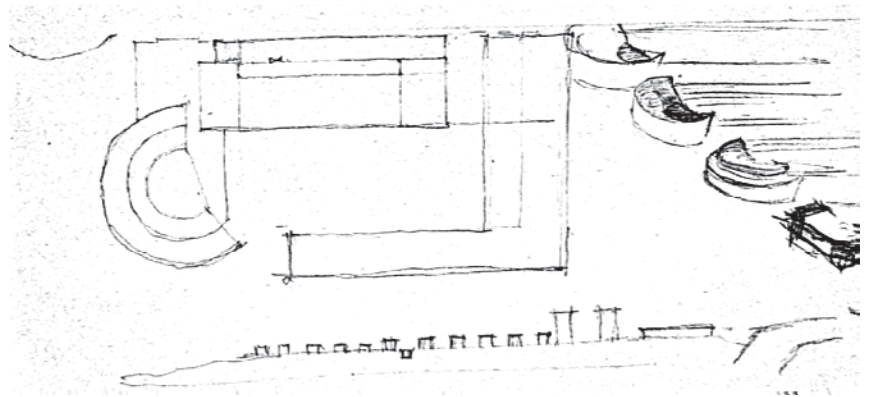

O7b

FIG O8 – Fragment of the final drawing of Aalto’s composition for the north of the hospital complex of Zagreb with the five clinics and Radiology center, source: AAA

FIG O9 – Trade Fair Building at the Institute of Technology, 1921, source: Schildt, 1994a, (AAA)

FIG O9a–Early drawings of the competition entry for the Finnish Parliament House, 1924, source: Schildt, 1994a, (AAA)

FIG O10– Drawings of the unrealized entry for the Palace of the Nations, Genève, 1926, Schildt, 1994, 128, source: AAA

FIG O11a – The first version of the Viipuri Library (1927-1935), Aalto, source: Schildt, 1994a, (AAA)

FIG O11b - Kalvia Sanatorium, 1929, Aalto (1929), source: Schildt, 1994a, (AAA)

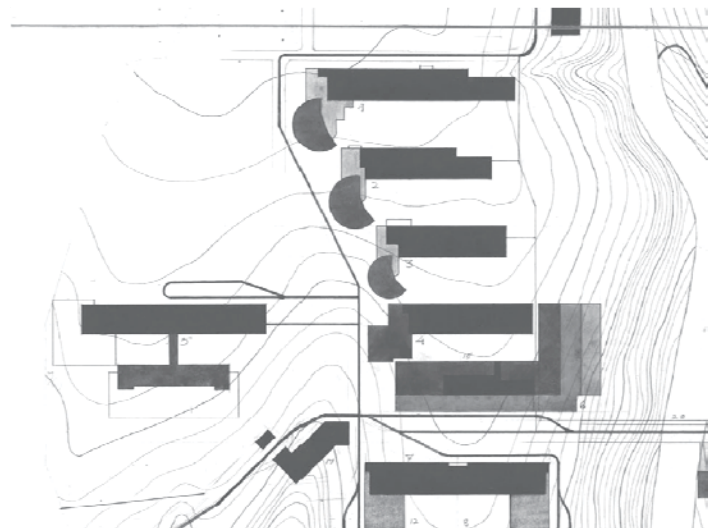

O8

On the early sketches, especially on the sketch (50/490) (Fig 07), is evident that Aalto wanted to create a dialectical image of the whole hospital complex on the hill viewed from the city and to make a uniform and a dialectical image of the "whole" with curved forms of the auditoriums of the north of the complex and behind the existing old Pediatric and Dermatology Clinic with a semi-circular annex on the main façade. The first horizontal main path of the complex is the "limit" of the dialogue between the rectangular and parallel clinic buildings of the General Hospital complex on the other side of the main horizontal route of the complex and at the same time with the three clinics with amphitheatres of the other side of this main horizontal path. The Radiology and Physiotherapy Center and Ophthalmology Clinic, placed right in the center between these two main parts of the south and north of the complex (from the competition program), could be understood as the *"transitional form"* which have the formal characteristics of both parts of the complex and where Aalto applied the "mimesis" between the two forms of "different nature". This phenomenon is also possible to connect and understand with the "spatial theory" of the two ecosystems in nature, where one ecosystem takes characteristics of the other nearby ecosystem. Moreover, also, this occurs alike the *"edge effect"* between the different parts of the complex (as the intermediate area between the two ecosystems in the nature: "ecotone" where on the limit, border, penetrate one context into the other, in this case of the Aalto's proposal the old and new context).

Aalto's background of the rectangular "head" of the composition:

- Aalto's graduate project of the Trade Fair Building at the Institute of Technology, 1921. The plan and elevation drawings (Fig O9) show us one classic monumental composition with the rotated rectangular "head" of the composition, as the "tower" that give the "power" of the composition.
- Competition entry for the Finnish Parliament House (1924, unrealized) (Fig O9a)
- Competition entry for Viinikka Church, 1924 (Fig O10) where it's observe the "L" shape of the floor plan with the rectangular "head" of the composition, analogous to the composition of the:
- Viipuri Library competition project (1927-35) (Fig O11a) and after applied in the Vila Mairea project (1937/38)
- Kalvia Sanatorium, 1929, Aalto (1929) (Fig O11b)

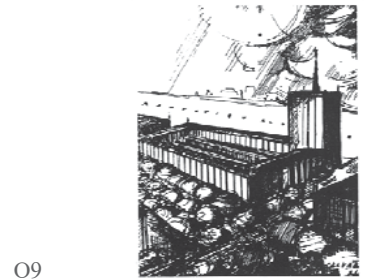

O9

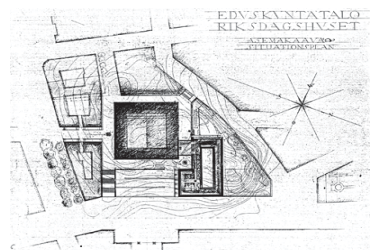

O9a

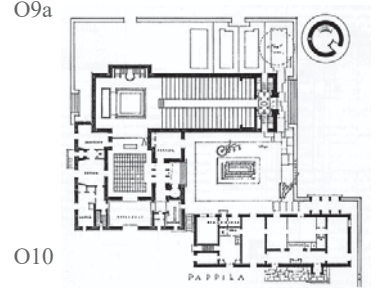

O10

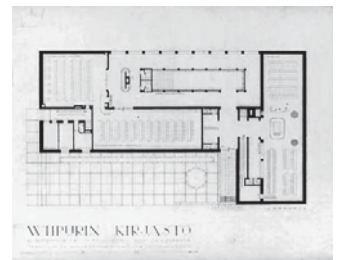

O11a

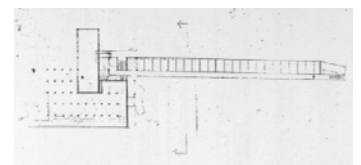

O11b

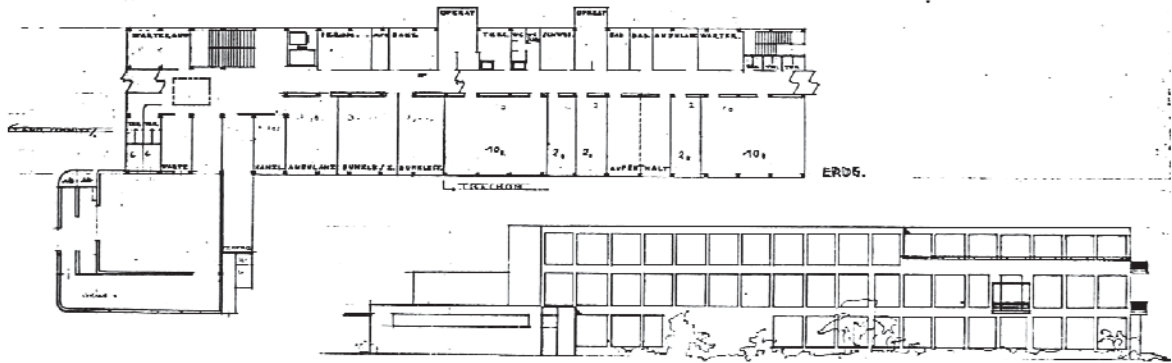

O12

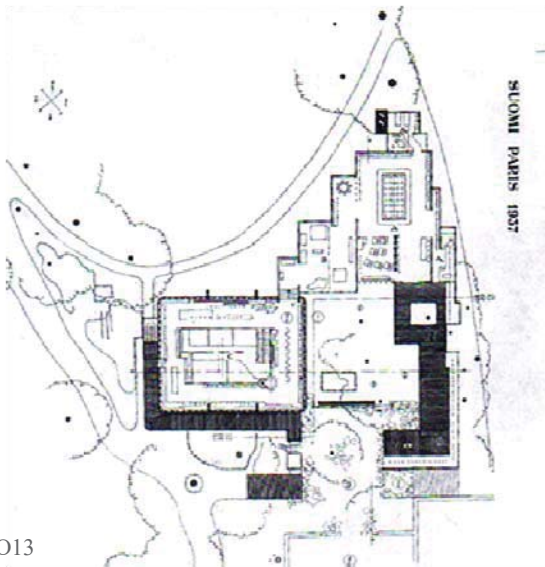

O13

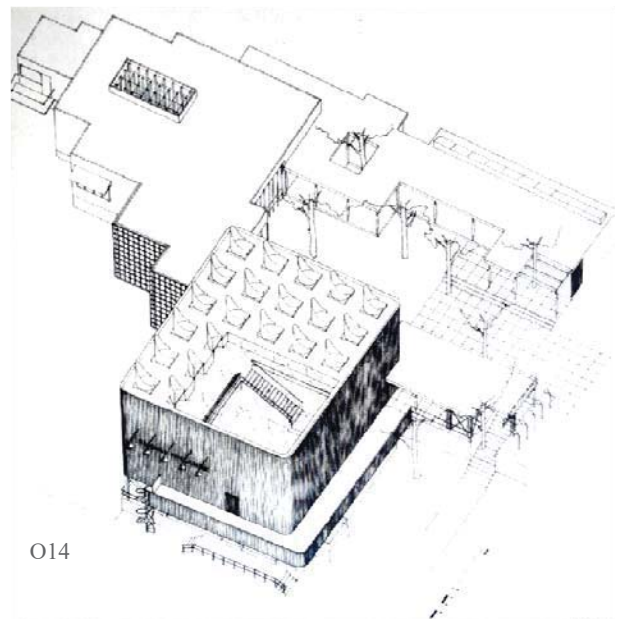

O14

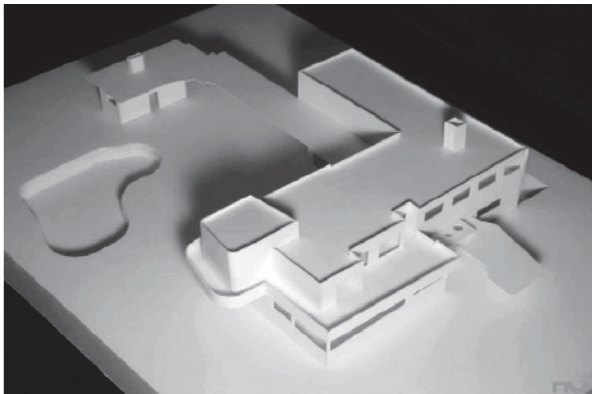

O15



O16

Here in the composition of the Ophthalmology clinic it is observed Aalto's principle of the characteristic rectangular auditorium - "head" of the composition with rounded/"trimmed" corners, applied in many future projects for different uses, as one of Aalto's "leitmotifs". He applied the similar "head" with the "trimmed" corners, some years later, on the Exposition Pavilion of Finland in Paris, 1936-37, (Fig O13-14), and in that same time he created one very similar form of the square annex with rounded "trimmed" corners as the "head" of the "L" composition house in the case of Villa Mairea 1937-38 (Fig O15-16). One synthesis of this rectangular "heads" of the composition, graphically is depicted by Andres Duany in his analysis of Aalto's architectural language. (Fig O17) It is possible to find an analogy of the square "head" and the characteristic similar "closed" rectangular composition of the Ophthalmology Clinic together with the Radiology Center of the HCZ Aalto's competition entry, and the central rectangular courtyard, in the case of the Administrative building of Saynatsalo (1949-1952)(Fig.O18-19).

Very similar rectangular annex element with the "trimmed" corners, we can find also as the parts of the main building of the University complex of Otaniemi (1955). Also, it is observed this leitmotif of the auditorium, as the "head" of the composition, of the Aalto's famous libraries and culture center of the Wolfsburg cultural center and the parish church with "trimmed" corners of the segments on the circle path. Often in his projects he applied the synthesis of few principles together: biodynamic composition: head and body, square auditoriums with rounded corners, repetition of the same species, daylight system and often stepped in the horizontal plane (as in the case of Finish Pavilion for Expo in Paris, 1937), and also in the vertical plane.

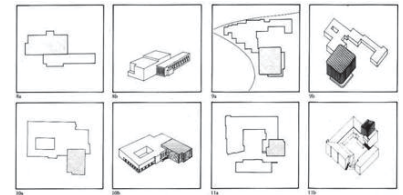

O17

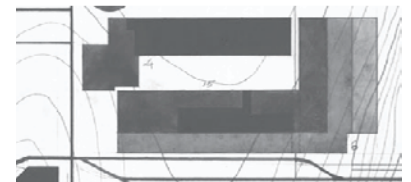

O18

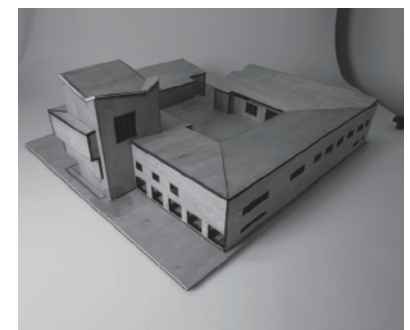

O19



O20

- FIG O12** - Floor plan and façade of the Ophthalmology clinic of the competition entry for the hospital complex of Zagreb, source: AAA
- FIG O13** - Pavilion of Finland, Exhibition of Paris (1937), Aalto, stepped floor plan, source: AAA
- FIG O14** - Pavilion of Finland, Exhibition of Paris (1937), Aalto, stepped axonometric drawing, source: AAA
- FIG O15** - Villa Mairea (1937), photo of the model, source: HO, web "historia en obres", Upc, F.Alvárez <http://www.historiaenobres.net/>
- FIG O16** - Villa Mairea (1937), photo of the façade, AAA
- FIG O17** - Sketches by Andres Duany of the analysis of the composition and forms of the work of Aalto, source: Andres Duany, web.unich.it (consulted 10.4.2014)



R.a

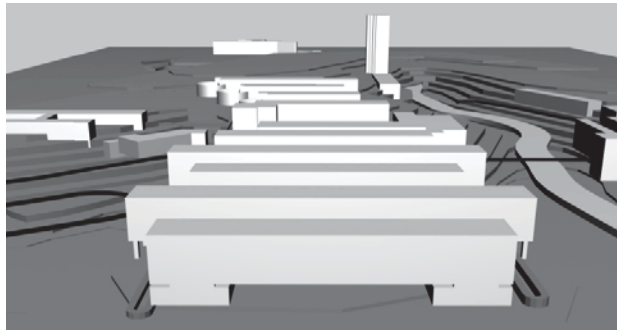

R.b

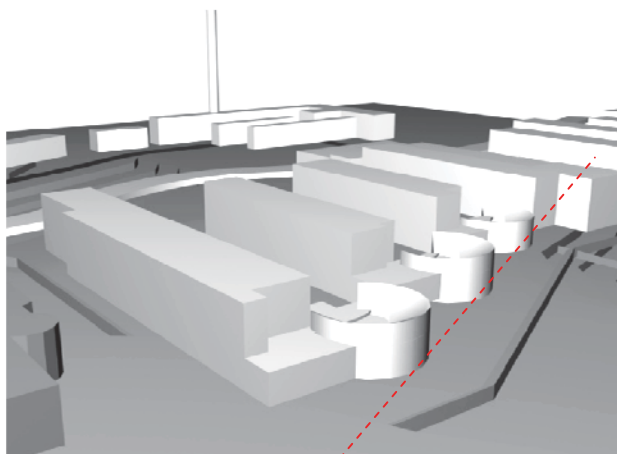

R.c

FIG O18-Fragment of the plan 50/610 of the "closed" rectangular composition with the rectangular courtyard of the two clinics: Ophthalmology and Radiology, competition entry of HCZ, 1930/31, Aalto, source: AAA

FIG O19-Model of the Saynatsalo town hall, closed rectangular composition with the square auditorium and courtyard, 1949-52, Aalto (very similar to the rectangular composition of the part of HCZ(Fig. O18)source:*HO,Upc,F.Alvarez* <http://www.historiaenobres.net/>

FIG O20 - Rectangular annex (with the "trimmed" corners) of the part of the main building of the University of Otaniemi, Aalto, 1962

FIG R.a – Fragment of the re-elaboration of the Final drawing of Aalto's composition of the north of HCZ with the four University Clinics with the independence lecture halls.

FIG R.b – Repetition of the "same species" of the rectangular pavilions of the hospital clinics,HCZ

FIG R.c – Fragment of the 3d- model of the composition of the north of the hospital complex with the four clinics with lecture halls auditoriums



photo-montage of the segments of Melnikov "Rusakov club"

Surgery Clinic

Intern Clinic

Otorhinolaryngology Clinic

Ophthalmology Clinic

PRINCIPLE 4

**Multiplication of the same "species" - "Edge effect" -
decreasing order**

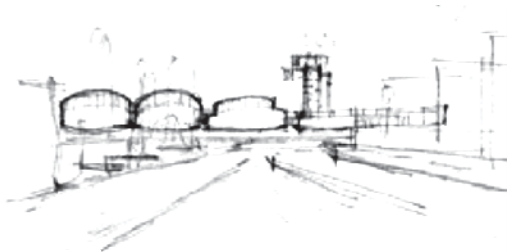

R1

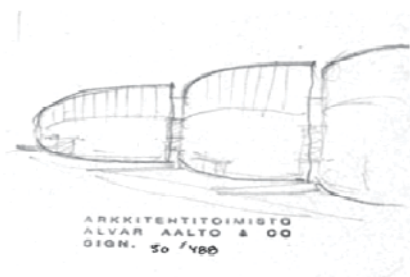

R2

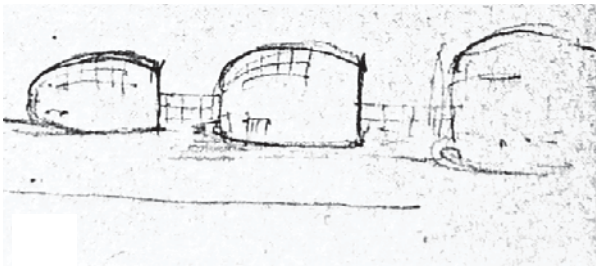

R3

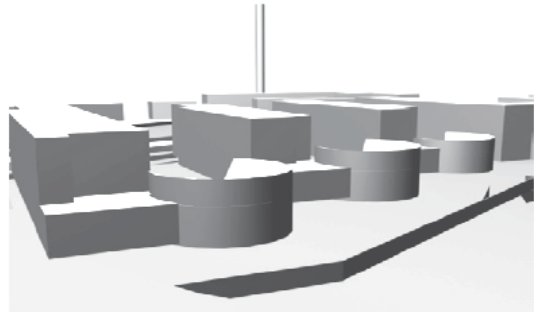

R4



R5

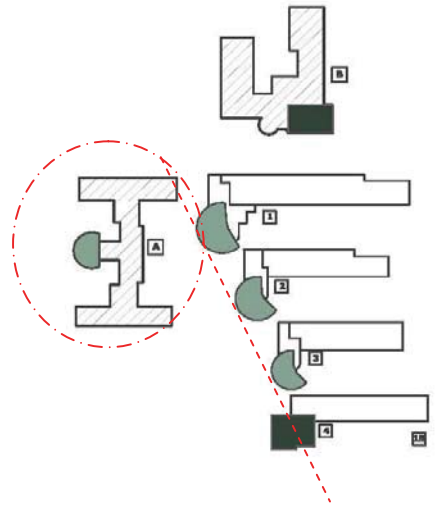

R6

FIG R1, 2, 3 – Aalto’s perspective sketches of the north of the hospital complex of Zagreb, 1930, AAA, 50/488 (multiplying, decreasing order of the three clinics with lecture halls-amphitheaters)

FIG R 4,5 – 3d models of the three amphitheaters of the Zagreb Clinics on the north. Multiplication of the “same species” with decreasing order.

FIG R6a – Multiplying of the amphitheaters of the HCZ following the diagonal path (on the limit of the site “edge effect” and viewed from the old and “new” center of the city).

The new principle of the circular segment repetition following the diagonal path

In the northern part of lot 1 Aalto has organized all clinic buildings of the School of Medicine, connecting with the old buildings of the School of Medicine (competition program) with the substantial proximity of the two existing clinic buildings next to the border of the competition site: Dean building (1917-1919, I. Fisher and F.Gabric) and Dermatology, Pediatric and Otolaryngology Clinic (1920-1921, F.Gabric). (Fig R6)

Aalto made a composition of the three lecture halls – amphitheatres of three clinics, applying the principle of the “multiplication of the same species”, followed by the diagonal path as the “delimiter” of the old Pediatric clinic in the front. He also formed an axis parallel to the main view axis of the old town due the proximity of the old Pediatric clinic at the front of a new clinic complex. In the other way, he created this composition by decreasing order of the three new clinics, influenced by the program which needed the different capacity of the clinic spaces and patient rooms. For that reason, Aalto prioritized elements of the north clinic respecting the list order of the clinics from the program of the competition and added to this “multiplication” principle also decreasing order.

Primarily, he placed on the north Surgery clinic, and then an Internal and Otolaryngology and the last the Ophthalmology Clinic, at the bottom of this part of specialized clinics (located next to the Foundation Hospital complex on the south). He created this composition of the northern part by ordering sizes of the clinics and amphitheatres in the perspective view of the “whole” composition of the three amphitheatres elements and the fourth rectangular lecture hall with the “trimmed” corners (with the circular amphitheatres), viewed from the center.(Fig R7-9)

In many of Aalto’s future projects, we can find this method of the semicircular segments “multiplication” in the perspective, follow the straight, diagonal or curved path. Aalto has developed this composition to make one “whole” of the context in a dialectic way with the existing building in the front of these buildings and also as a

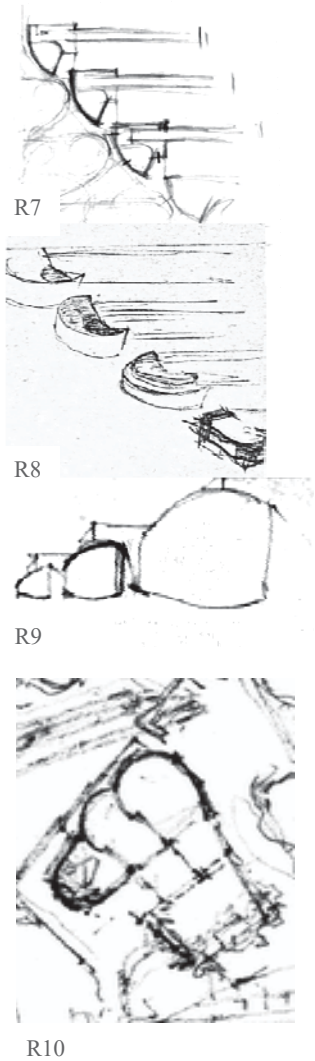

FIG R7, 8, 9 –Early sketches of Aalto’s composition of the four clinics in the north of the hospital complex of Zagreb, 1930, AAA

FIG R10 – Sketch of the floor plan of the Church of Three Crosses, 1955-58, Vukoseniska, Aalto,source: AAA



R11a



R11b



R12a

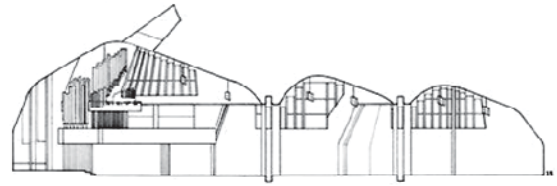

R11c

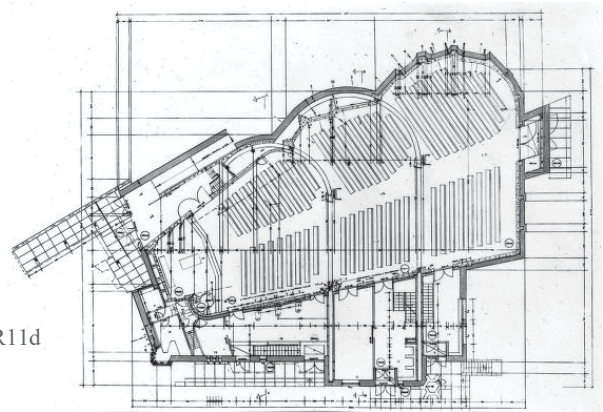

R11d

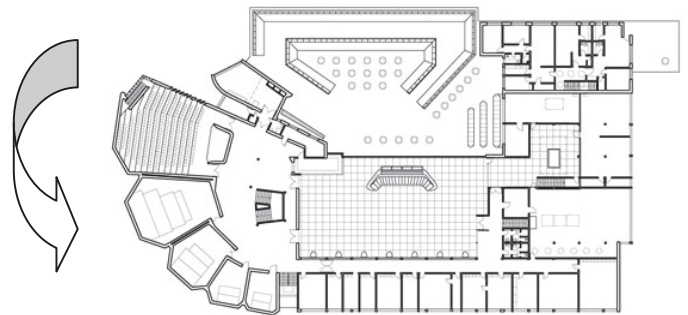

R12b

FIG R11 a,b –Church of Three Crosses, 1955-58, Aalto **FIG R11c**– Church of Three Crosses, 1955-58, Vukoseniska, section, Aalto, **FIG R11d**-Church of Three Crosses, 1955-58, Vukosseniska, floor plan, source: Schildt, 1994, AAA **FIG R12a** – Wolfsburg culture center, 1959, Aalto (perspective foto) **FIG R12b** – Re-elaboration of the floor plan of the Wolfsburg culture center, radial decrease of the size of the polygonal units of the fan shape of the "head of the composition."

front view from the old and new center as the main façade of the HCZ hospital complex, which Aalto called "Acropolis", with his characteristic lecture halls- circular amphitheatres repeated in the perspective view as the wall on the hill, giving the sensation of an old "fortification" with the rounded towers, where observed from the South and "new" city center, the old Pediatric and Dermatology Clinic looks like the fourth semi-circular element together with the three new lecture halls-amphitheatres, behind this old building of the composition. This principle creates one fragmented shape with the multiplications of the "same species" of semicircular segments, which we can understand as the one "phenomenon" of the "*edge effect*" on the border of the *spatial theories of ecosystems - "species multiplication" on the "border"* - and recognized as the one "principle" on many of Aalto's future projects.

Variations of the principle of the circular/polygonal segments repetition:

1. Following the straight/diagonal path and 2. Following the semicircle path

Aalto in his future works used this principle of the multiplication of the same "species"- (curved/polygonal/rectangular) segments followed by different paths (straight or diagonally) as on the observed composition with three semicircle forms on the floor plan and the section of the Church of the Three Crosses, Imatra, Finland. (1958) (FigR10, 11a,b,c). There he used this method to create flexible space of the church depending on the capacity (between the each of three elements he created mobile panels). Aalto also developed other variations of this method of the multiplication of the polygonal elements followed the semicircle path, as in the case of Wolfsburg culture center, (1958) (Fig R12c) where decrease size of the polygonal segments on the path in the perspective view of the floor plan is observe as the similar decreasing method applied of the three lecture halls (amphitheatres) of the clinics of Zagreb. Simultaneously with the size, he increased the complexity, capacity, form and light systems of these units of the composition.

The difference between the project of the Church of the Three Crosses, Imatra, Finland (1958) and Wolfsburg culture center (1958) appears in the repeating segments of different size with decreasing order. Both projects were simultaneously developed and the Wolfsburg Center represents the continuity of the same theory of elementary

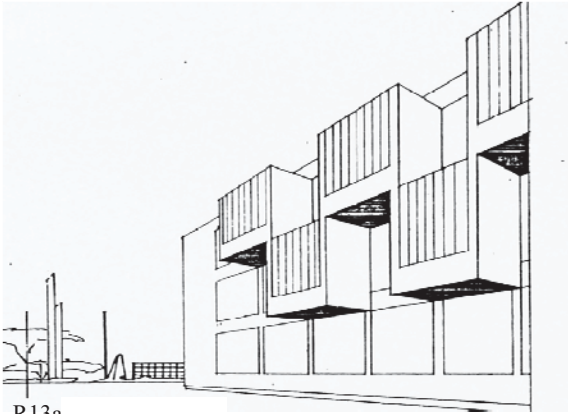

R13a

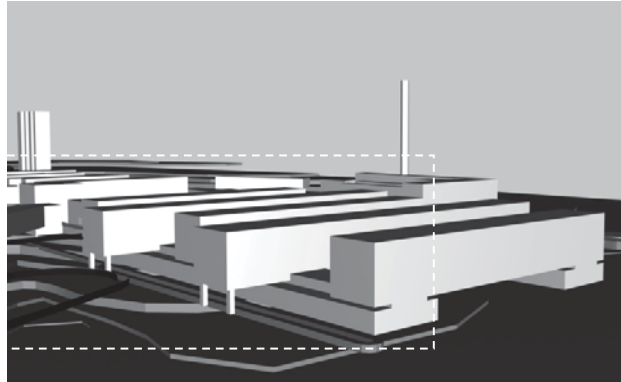

R13b



R14

FIG R13a – Perspective drawing of Aalto for the façade of Ophthalmology Clinic, Competition entry Zagreb, Aalto, 1930/31 source:AAA

FIG R13b – 3d- model of the multiplication of the rectangular pavilions of the General hospital of the south of the hospital complex of Zagreb

FIG R14 –Photo of the main façade of the Rusakov Club of workers, Melnikov, 1927 Source: Pennhistoryofart

FIG R15 – Part of the façade of the University of Technology (Now University A.Aalto) in Otaniemi.

FIG R16 – Kazimir Malevich, Suprematist Painting: Aeroplane Flying , painting, 1915., source: MOMA



R15

forms of the base, while fragmented segments of the Church of the Three Crosses illustrates the radical out-step of his previous "basic" shapes, having the more "organic" - free forms, as the one "mixed" shape, as a synthesis of both contours (straight and curved) joints together in the single free form. On almost all Aalto's works we observe that he applied the Le Corbusier's theory of the "correct ... play with elementary forms"¹, transformed in the late phases with many variations of the first principles applied together. It is observed that many Aalto's projects developed forms as a synthesis of the individual auditoriums joint together in a single unique shape. Moreover, he often applied the synthesis of the principles from this project: "head and body" as the one mobile spatial organism in the asymmetric movement, amphitheatres and rectangular "heads" of the composition with segments repetition on the path with decreasing order, and indirect daylight from the upper windows, sidelight source near the ceiling of the amphitheatre and double light sources with the skylight above the central zone .

1. Repetition of the rectangular elements "coming out" of the base

In a similar way as three-dimensional experiments with the series of the paintings and 3-d models of Proun of Lissitzky, Kazimir Malevich (Suprematism), and the strong influence of the architecture of Russian Constructivism, especially in the case of the composition of the Rusakov Club of workers by Melnikov, 1927 (Fig R14-16), Aalto on this competition entry of HCZ has experimented with different compositions which are influenced by the use of the same element, as the series of the semicircular and rectangular shape. That principle, of the "multiplication of the same species", we can find on the set of the lecture halls -amphitheatres of the clinics the School of Medicine, in the north of the complex and as well in the set of the Foundation Hospital in the south of the complex in Zagreb. This principle Aalto applied on three buildings of the Clinics of Internal Medicine, Surgery and Ophthalmology as the one of his "leitmotifs" recognizable in many of his later works where he established one

¹ Le Corbusier in " *Vers Une Architecture* ", 1923, explained the elementary forms and that are discovered, opposite to the forms of the Farm Gut Garkau (1925) of Haring at the same time , where Haring written that always must to discovered new forms (free to express each function by own form). Aalto started to form his language by the Le Corbusier's Theory of elementary forms and developed his own forms in the late phases closer to the Härings "new" forms.

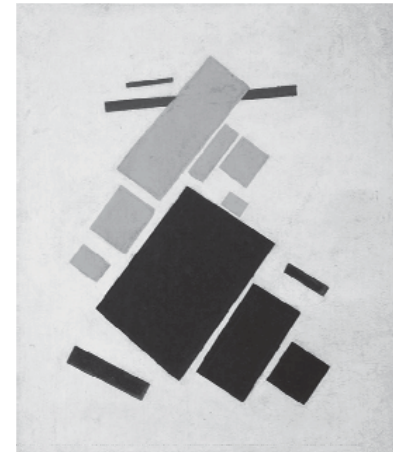

R16

FIG 17 – Perspective drawing of Aalto for the Façade of Ophthalmological clinic, Competition entry Zagreb, Aalto, 1930/31 source :AAA

FIG R18 – Villa Mirea,1937/8, floor plan (repetition of the windows cube elements).

FIG R19, 20 –Villa Mirea,1937/8, photos of the facade (repetition of the windows cube elements), Fleig K.,1995

FIG R20a – segment of the windows "coming out"of the façade

FIG R21 – Part of the façade of the University of Technology,1949-1964, (Now University A.Aalto) in Otaniemi, Aalto

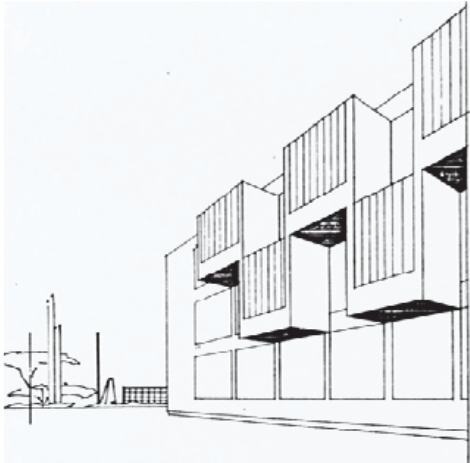

R17



R19

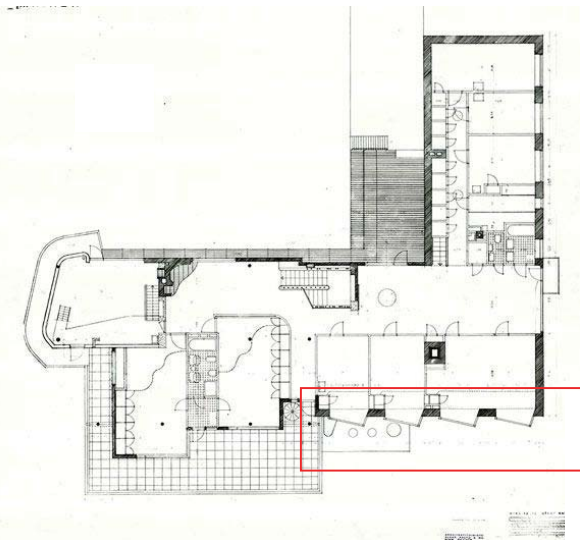

R18

R20



R21

original concept of the Ophthalmology Clinic façade (optional, perspective drawing (Fig R17)), applying the new principle of the multiplication of the one rectangular element on the "surface". In these rectangular elements of the façade, Aalto planned the operating surgery rooms coming "from inside – out", as the one part of the exterior. He developed this façade composition, as the "therapeutic façade" to provide the best insolation of the operating room (for eye surgery), and at the same time these outgoing "cubes" of the operating rooms, as the free consoles of the façade, are designed to provide the shadow and less intensity of the light after operations in the patient rooms below. Also, Aalto developed this façade composition for the protection of the patient rooms from the noises from the frequent use of surgery rooms above (floor-console).

The composition of the "cubes" that "coming out" of the base (façade) we can find previously on the famous Melnikov Rusakov Workers Club (1927)(Fig R24), which was the very known and published building at that time. In this case, three rectangular elements are going out from the base, created for the acoustic reasons of the concert hall. By observing both façades,we could imagine that Aalto analyzed and wanted to reinterpret the similar ideas of the multiplying of the "same species" following the path. In the case of the façade of the Ophthalmology Clinic of Zagreb, he applied this principle for the "health" reasons and later he will use the similar concepts of the three cubic elements that "coming out" from the base, for the different reasons: concert hall of the Finland Hall (1961-1971)(Fig R25) or on his projects of many libraries, cultural and educational buildings. Repetition of the square elements as the annexes of the plain façade, we observe for the first time in a drawing as the alternative façade solution for the Ophthalmology Clinic of the HCZ, find also in the main part of the façade of the Villa Mairea (1938). (windows "stick out" of the base - façade), (Fig R18-20). This method relates the Aalto's work with Goethe's philosophy (*from the inside to outside*) as the unity "without the limits" between the exterior and interior space. In the case of the cubes - windows from the Vila Mairea façade Aalto applied this principle to different conditions of insolation and to a different orientation, where Aalto wanted to provide the best insolation with the South orientation, but avoided

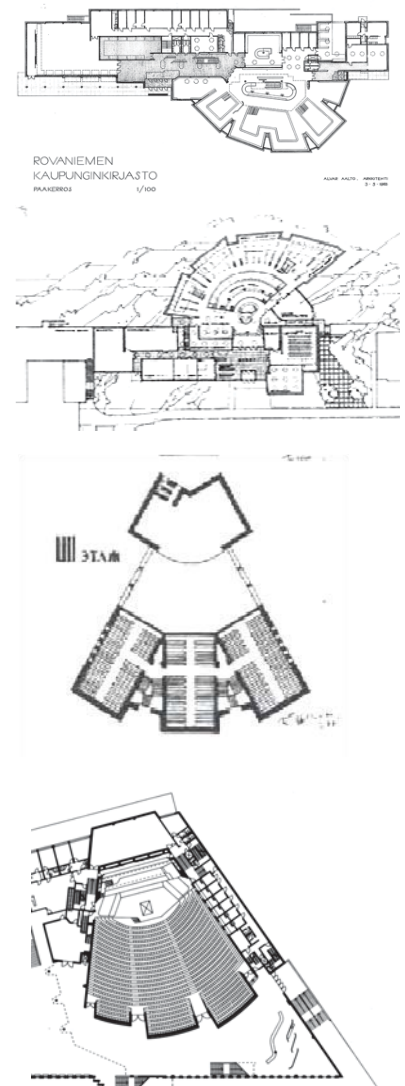

R22-25

FIG R22 - Rovaniemi library, Aalto, 1961, floor plan, AAA

FIG R23 - Mount Angel Library, Aalto, 1965-1970, floor plan, AAA

FIG R24 - Concert hall of Rusakov Club of workers, Melnikov, 1927, Moscow, floor plan, source: *arthistory.upenn.edu*

FIG R25 - Concert Hall of Finland Hall, Helsinki, Aalto, 1962, floor plan

FIG R26 - Rovaniemi library, Aalto, 1961 perspective façade photo (repetition of the fan-shaped forms of the amphitheatre), Schildt, 1994

FIG R27 - Mount Angel Library, Aalto, 1965-1970, perspective façade photo (repetition of the fan-shaped forms of the amphitheatre), Schildt, 1994

FIG R27a - Rovaniemi Library, 1961, Aalto, early sketch with the multiplication of the - circle segments on the semicircle path, AAA



R26



R27

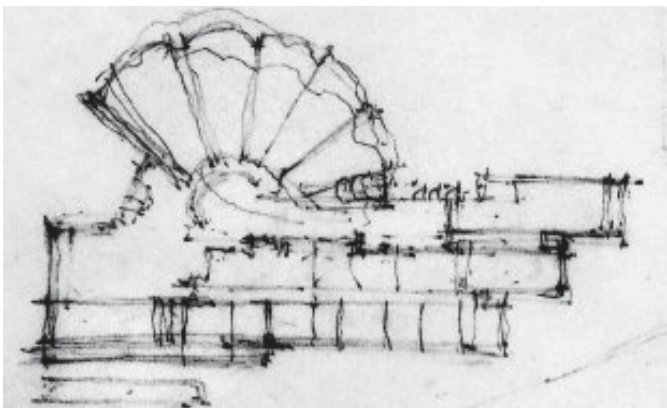

R27a

the direct sidelight by the outgoing cubes, and sequentially he rotated the "cubes", annexes of the façade toward the South. These rectangular annexes of the main facade which "leave their base" and create a dynamic composition of discontinuity inside the continuity of the main "path" by the methodology of multiplying the "same species" is Aalto's recognizable principle, observed on some well-known examples of Aalto's work: cultural center of Wolfsburg (1958), Finland Hall in Helsinki (1962), with the "fan shape" and the rectangular annex repetition on the fan-shaped "head" of the composition of the Rovaniemi Library (1961), Oregon Library Mount Angel (1965-70), (Fig R12a,b,c,22-28) and many others. Fan-shaped "head" of the compositions with the repetition of the segments followed the different path, curved and straight, where Aalto has considered this shape for buildings with different uses: administrative, culture, of education, libraries, concert halls, theaters, churches, as the "universal substance" which gives the harmony, balance, between the many specific functional requirements.

In the case of the concert hall, this form has the primary acoustic function, where Aalto places the public space of the concert hall. In the case of the libraries, he used this form for various reasons where the most important is a light condition, and, also, these independent, outgoing segments of the façade of the "amphitheatre", in the library hall, he used as the semi-individual lecture spaces with intention to obtain the reading with more privacy (small segments inside the large hall space), and it is used to organize the groups of the bookshelves. Frequently, these segments are rectangular, just on the early sketch of the Rovaniemi library can notice one variant of the curved segments repeating on the radial path (Fig O6). Central library hall, he designed using the few high levels with the double daylight sources (as in the case of the amphitheatre of the University of Zagreb where the system of large upper windows is situated next to the ceilings), to enable the indirect light and the correct penetration of the light inside the interior spaces. In the administrative, cultural and educational buildings he used these annexed forms for the different offices and independent congress rooms, so that each one could have the best acoustic features. In the case of churches (as Imatra's church) he created one flexible space, dependable on the capacity of the visitors of the space, where each one of the units could have an independent function or integrated together provide the maximum capacity for the visitors and each unit with the best acoustic features.

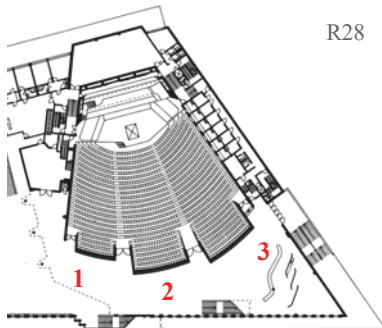

R28



R29

FIG R28 -Concert Hall of Finland Hall, Helsinki, Aalto, 1962, floor plan and façade, Three segments of the concert hall reflecting as the repeated element of the “same species” on the façade

FIG R29 - Salle Pleyel, 1926, Gustav Lyon , Paris. It can observe segmentation of three elements which are separated on the Rusakov workers club of Melnikov (1927) or later on the Finland Hall of Aalto (1962) for the acoustic reason and it is one of the main leitmotifs of Aalto’s fan-shaped auditoriums

FIG R30 – Concert hall of Rusakov Club of workers, Melnikov,1927, Moscow, floor plan and section *we can observe this segmentation of three public areas for the acoustic reasons reflecting also on the façade (similar to the repetition of the rectangular element of the Ophthalmology clinic of the hospital complex of Zagreb, Aalto, 1930, source:*Pennhistoryofart*)

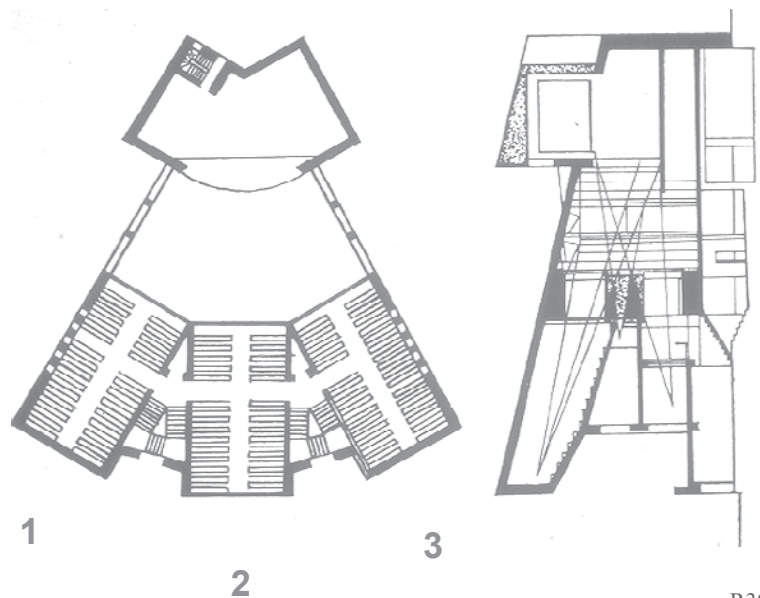

R30

PRINCIPLE 5

Daylight Techniques

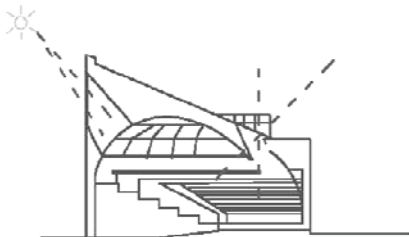

L1

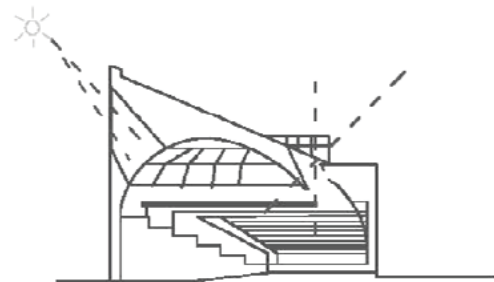
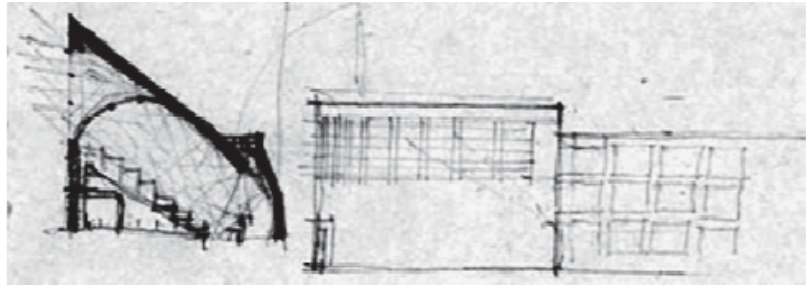

L2

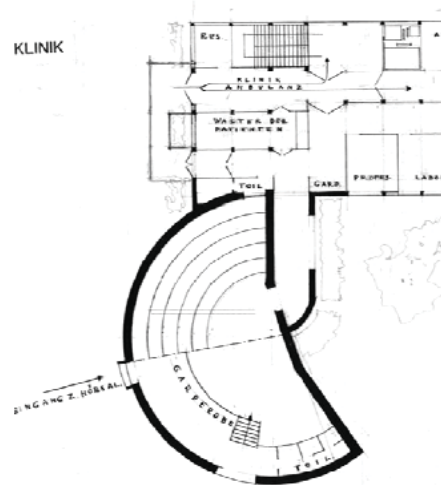

L3

FIG L1 – Sketches of Aalto’s section and façade of the Lecture Hall of the competition entry of Zagreb. We observed double light sources, one lateral indirect light next to the roof and other skylight of the ceiling (the skylight analogues to the Mount Angel Library, Oregon, 1970. as on the many fan-shaped forms applied by Aalto to provide the indirect diffused light, source: AAA

FIG L2 - Section of the Lecture Hall of the Clinic of HCZ and marked penetration of the double sources of daylight of the Amphitheater. (own drawing), source: AAA

FIG L3 - Segment of the final drawing of the Intern Clinic for the competition entry of HCZ , (1930/31), Aalto 50/615, AAA

FIG L4 – Superior windows next to the roof providing the diffused indirect daylight in the Sport Hall of Otaniemi (1962),Aalto,source: AAA

FIG L5 – Upper windows of the Lecture Halls of the Clinics of Zagreb. Early sketches , Aalto (1930). Very similar to the upper windows as the universal solution on many of his amphitheatres with many uses (as Three Crosses Church or Libraries)

FIG L6 – Upper windows next to the roof for enable indirect light (spiritual-as in the cave). Church of Three Crosses, 1955-58,Aalto,source:Shildt,1994

FIG L7 – Section of the Lecture hall of the clinic of the competition HCZ

L4



Daylight techniques

For Aalto, in a similar way as Hugo Häring² (who had an influence on Scharoun and Aalto), the light is a game which changing elements in architecture. The main issue to solve is adapting the interior source of light in the same way as the exterior one, with the same nature. For Häring, only the sidelight source of daylight is inadequate and creates too many shades in the interior, whereas the five points of Le Corbusier, and the free facade increases the intensity of direct sidelight.³ Aalto used inspiration from the "illusionary" Asplund's interiors and from the architecture of Ancient cultures of Egypt, Mesopotamia, Greece, Rome with "sacred" aspect.

Aalto's daylight's source of the clinics and their lecture halls of the HCZ is the technical, functional and at the same time poetic and spiritual (as the light of the cave) (Fig L1-L5). This system of the upper windows on the top of the facade below the ceiling of the "heads" of the composition, he applied on many future buildings, where on some sketches, we observe that this upward slant windows he also applied in many of his works, as in his studio in Munkkiniemi, what also confirmed Goran Schildt in his short description of this project.⁴

The importance of the light treatment is another constant of Aalto's work. In the project of Sanatorium Paimio, he started to experiment other daylight techniques with primary "therapeutic" character. In the lecture halls-"amphitheatres", he used a new window system also to avoid possible distractions of students, and provide the best light for reading, the same method that he uses on many of his libraries (upper position behind the public space of the lecture hall). Aalto also used this principle of the daylight in religious buildings, with spiritual "effect" as we can observe in the Church of Vukoseniska (1958)(Fig L6) or the Wolfsburg Parish Church (1960-62), and many others. Moreover, we observe this method in many libraries: Rovaniemi (1961), Mount Angel Library, Oregon (1970).(Fig L8) Sidelight situated next to the roof of the amphitheatres is the main source of the indirect light in many fan-shaped forms of the Aalto Architecture.

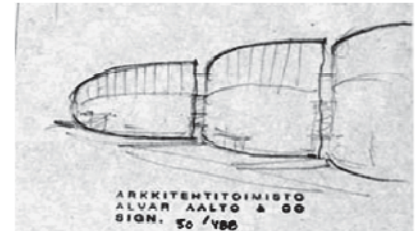

L5



L6

² Häring was founding member together with Mies Van de Rohe of the Ring and after CIAM

³ H. Häring "Problème des Bauens", *Der Neubau*, Blundell-Jones (translation), Heft 17, 10 september 1924

⁴ Schildt, 1994:69

Effect of the diffusing of daylight penetrated from the upper windows and the "conic space" above the beams of "cupola". Effect of the light access into the Cave. "Sacred" character of the lecture hall of the "amphitheater" of Zagreb clinics and library central hall of Oregon library.

The source of light hidden from the direct view, on the other side the "step" skylight with the similar characteristics.

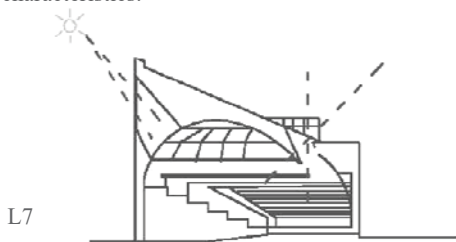

L7



L8



FIG L8 – Photomontage (mirror photo), of the interior of Mount Angel Library of Oregon, Aalto, 1970, diffused indirect skylight of the right side. If we looking in the mirror this image we can imagine upper windows next to the roof of the main façade and on the other side the skylight with the similar form, "hidden" from direct view, in the form of the "step" of the Lecture hall of the Clinics of the School of Medicine of the HCZ competition entry



L9



FIG L9 diffused indirect daylight above the cupola as the system of the curved beams in the Lecture hall-Amphitheatre Technology University, Otaniemi, 1962 (similar system of the cupola of the beams in the Amphitheatre of Zagreb, 1930)

L10a – Vukosseniska Church, upper light.

FIG L10b – diffused indirect daylight into the central place, more intensive in the place of lecture, upper windows, situated next to the roof, "conic" entrance. Library University of Technology, Otaniemi, 1962 (similar system of the conic entrance of the diffuse sidelight into the Lecture hall - amphitheatre of Zagreb



L10a



L10b

In his studio in Munkkiniemi, in the mid-fifties, it can be observed his efforts to assess the homogeneous light use, but in this case he opted for a double sidelight situated on the different level always avoided the direct contact with two sources of the double sidelight. Aalto placed high skylights which provide a central, neutral light while allowing the direct eye contact with the skylight source from the workplace (also masked with beams of the "cupola").(Fig L8) He always wanted to make one natural synthesis as the fusion of the exterior and interior space, avoiding any direct impact of lighting in the interior space and providing the gentle and densely light penetration (as in the case of the daylight entering the cave with "full volume and weight"). He looked for one homogeneous, indirect light and applied double lighting of the auditorium (two sources), first upper windows, on the rounded façade of the amphitheatre, next to the roof to enable diffusing the light into the interior (south-west oriented windows) and another source of the east oriented step-skylight above the part between the stage and the audience. Upper placed windows, above the "cupola" of the beams of "amphitheater" next to the concave roof that allows to diffuse the indirect light source, in a similar way as in the exterior space.

The similar system of the light, penetrated above the cupola of the beams, we find twenty years after in the lecture hall in the Otaniemi University of Technology.⁵ (Fig L9-10). Light is an essential theme in Aalto's work and have a functional, human and spiritual value at the same time. Aalto explained, that the architect has a task to humanize the mechanical nature of the materials, and to achieve this: light has an important role to provide the visibility and aid to bring the man to the human and naturally astonish, which is founded and used since the prehistoric man, and in this example, Aalto created the spaces with the spirit choosing a human, not a mechanical or purely rationalistic system (light from *Le Corbursier's the five points of the functionalism* of the free facades and direct sidelights). Finland is a country with the horizontal and cold Nordic light (climatic contrasts and the absence of light) and provided the natural light captured from nature to the hospital he makes the warmer space while giving a calm and spiritual atmosphere inside.

⁵Also, we can subsequently affirm that from the critic of Malcolm Quantrill, about the lighting of the Lecture Hall of Zagreb hospital complex in: "*Aalto: A Critical Study* ", 1983 :59



L11

FIG L11 - Sketches with the Aino Aalto sign on the technical details of the new daylight system, new system of windows with slide-up open system which Aalto used later on many projects,50/506a, source:AAA

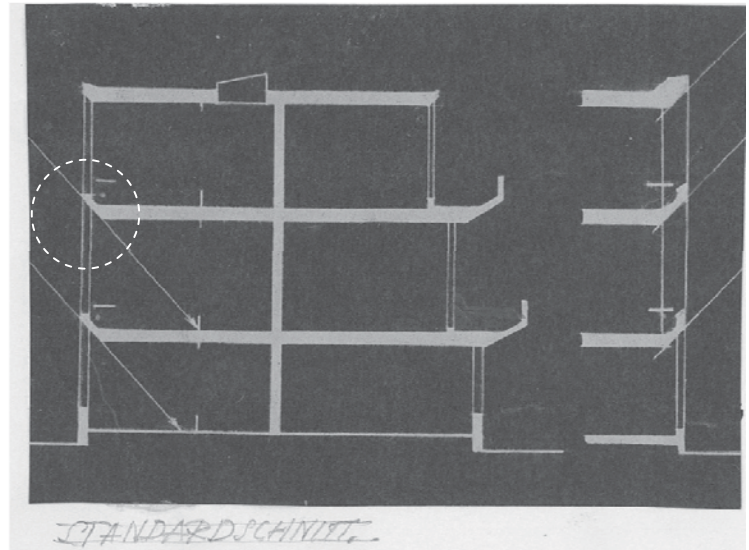

L12

FIG L12 - Drawing of the section of the clinic of the hospital complex Zagreb with marked entrance of the sidelight, extension of the angle of the penetration of the daylight. drawing from his technical description of the competition,source:AAA

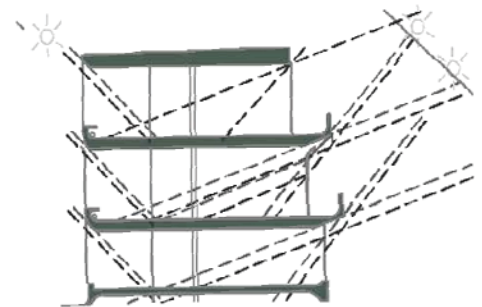

L13

FIG L13 - one sketch with marked entrance of the sidelight, extension of the angle of the penetration of the daylight, for give more light to the central interior hall which is separate from the rooms by transparent glass panels.

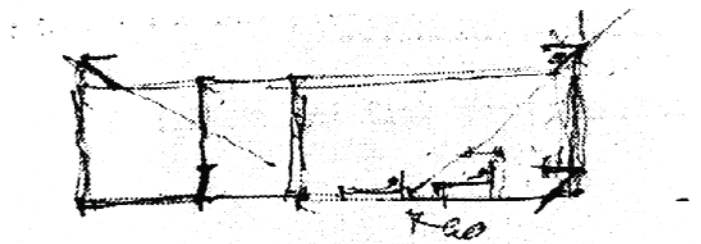

L14a

FIG L14a - Sketch of Aalto of the extension of the angle of the sidelight, above the upper floor, on this way Aalto enable indirect light, extension of the surface of the floor of the rooms with this light which come to the central interior hall between the room separated by glass panels, and in the same time enable the best ventilation and protection from the winds on the hill., source: AAA



L14b

FIG L14b - Sketch of the Ophthalmology clinic or Orthopedic with the original position of the daylight source with the inclined "cubes" - on the façade of the operating room, with this system he obtained the extension of the part with the operating bed and the direct light source

Aalto wanted to give the best use of natural lighting and to introduce into the "cold" hospital space by diffusing the indirect light. In this way, he created a warm space and shelter from the strong wind on the Salata hill. By using the horizontal windows with the direct eye contact, they can produce distractions and he wanted to avoid direct contact with the source of sidelight in the lecture hall, applying the same system which he used later in the lecture areas in many of his libraries, as the main light source from the ceiling and upper windows next to the roof and in this way he created a spiritual space oriented to learning (natural interior as the exterior source of light). Aalto in this way converted the one educational space in the "sacred" space. On the concave roof of the auditorium of Zagreb, he created a stepped skylight ("cone" effect as the filter of the light intensity) and this approach allowed him to mask the light source from the direct view of the students. Stepped skylight on the concave roof of the Zagreb Lecture Hall as the only one step of the open-air amphitheater, he used because here he applied a double source of light, with the upper sidelight as well.

The roof of the lecture hall of Otaniemi has less concave form, whereas the roof, he designed as the stair-stepped light source yield a more intense light without sidelight established on the open-air amphitheater of the concave roof. In the case of the libraries in Seinäjoki, Rovaniemi or Oregon Aalto implemented the same system of the daylight from the amphitheatre of Zagreb, one stepped skylight, masked direct view of the source above the "cupola"- beams, and upper windows as the sidelight source. He also used this double daylight source, as the sidelight and the skylight in the outgoing operating rooms – consoles of the facade (as the example of the Ophthalmology clinic adapted for the delicate eye operations).

By analyzing all drawings of Aalto's competition entry of the HCZ, it is observed that he also used another new technique of daylight system, which he applied to the hospital rooms in this project as the new principle of the "extension of the angle of the sidelight", where he avoided the direct sunlight and discomfort, while providing the best ventilation of the rooms from above the limit of the ceiling of the room (Fig L12,13,14).

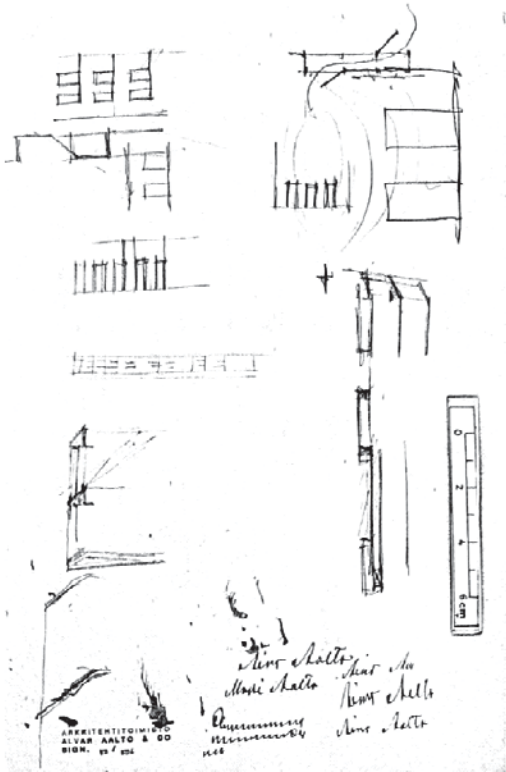

L15

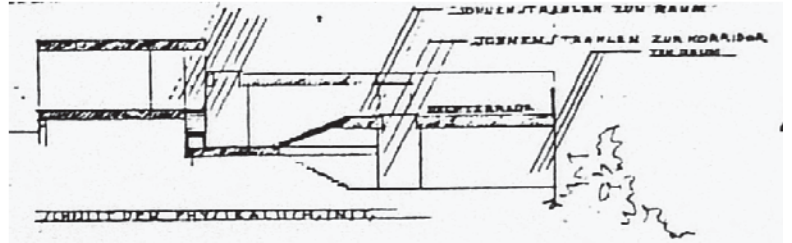

L16

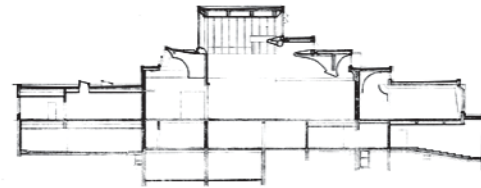

L17a



L17b



L17c

FIG L15 - Sketches with some Aino's name signature. Different technical details of the new daylight system, new system of windows with slide-up open system which he used later on his projects, system of ventilation, *some system used on the Paimio sanatorium where at the same time with this competition entry of HCZ, he developed final drawings of the realization of the Paimio sanatorium (1928-1933),50/506a,source:AAA

FIG L16 - section of the Radiology and Physiotherapy center of the hospital complex Zagreb, Aalto, 1930/31, source: AAA
 FIG L16a - Section of Museum in Aalborg, 1958, Aalto, upper windows of the stepped vertical plane as in the Center of Physiotherapy of the competition entry of Zagreb, Aalto (1930/31)
 FIG L17 - Museum of Aalborg (1958), Aalto, stepped vertical plane together with the upper windows. Similar composition and applied daylight system of the Radiology and Physiotherapy Center (L16) in the vertical plan, in this case of Zagreb competition entry, following the sloped configuration of the hillside
 FIG L18 - Museum in Jyväskylä, 1971, AAA, (daylight, upper windows in the stepped vertical plan)



L18

In that way Aalto avoided any discomfort enabling the best ventilation and, also, at the same time, protection from the winds on the hill. (ventilation "through the "conic" space between the upper window and the limits of the ceilings which "filtered" the air and diffused the light at the same time). Applied this system he provided more light to the central hall of the clinic separated by the transparent glass panels of the rooms. Some of the details of these new systems of the daylight and ventilation from the HCZ competition entry he will use in the future projects. As pointed by Goran Schildt: *"Another element introduced into this plan consists of the upward-slanting window openings used by Aalto to improve the lighting of many buildings, including his office in Munkkiniemi (1955)"*⁶ (Fig L15). In this sketch we can clearly distinguish several Aino Aalto signatures, which show us her substantial participation in establishing the main ideas of HCZ competition entry together with Alvar Aalto, influenced many of Aalto's future projects.

Another daylight system that Aalto used in this HCZ competition entry, for the stepped Center of Radiology and Physiotherapy, is the upper windows system applied together with the other principle of the stepped vertical plane of the facade. (Fig L16) In that way, he provided an indirect light and avoided any discomfort in space with ameliorated ventilation. In HCZ project Aalto, followed the natural configuration of the terrain to make this system of the light. At the same time, the upper windows are used as the access to the upper terraces for the staff to avoid direct views from and into the clinic spaces and also avoided direct negative influence from the road next to this clinic on the hillside and direct view of the community service center in the front of this building on the other side of the road. Aalto divided on three parts the floor plan of the Radiology Center and the Center of Physiotherapy, in "L" position, each one with upper side light in the vertical plane, avoided direct contact with the light source and he formed all hallways with daylight - skylights. (Fig L16,16a). This similar system is used in many of his future projects frequently applied together with the other principle of the stepped vertical plane, as in the case of the Museum of Aalborg (Fig L17a,b,c) or his Museum in Jyväskylä (Fig 18) and many other works where he applied these new daylight techniques.

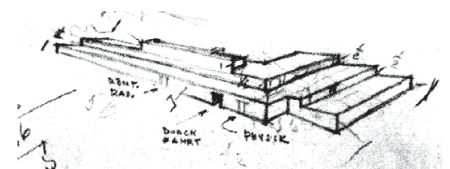

L16a

⁶ Schildt, 1994:69

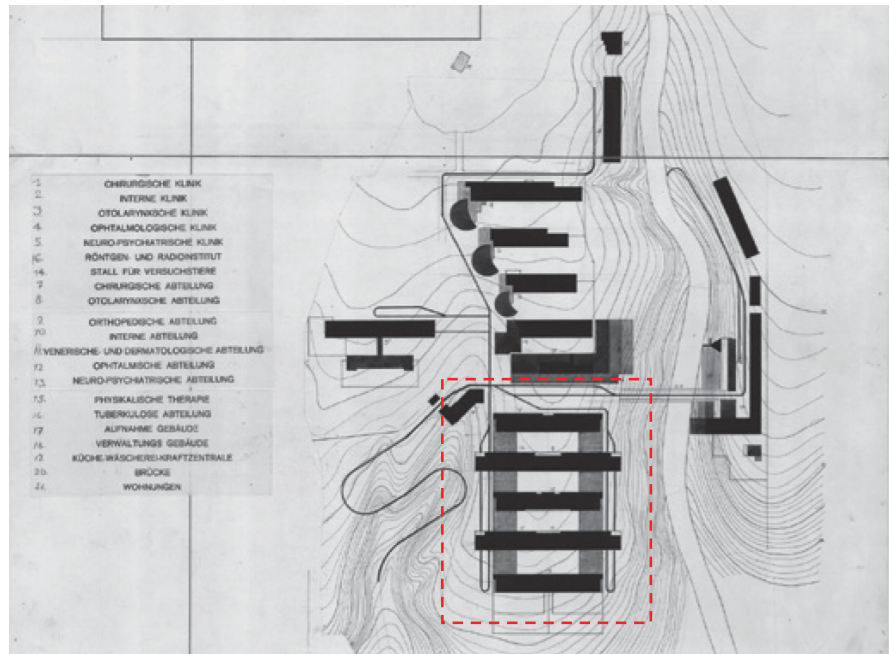

HG1

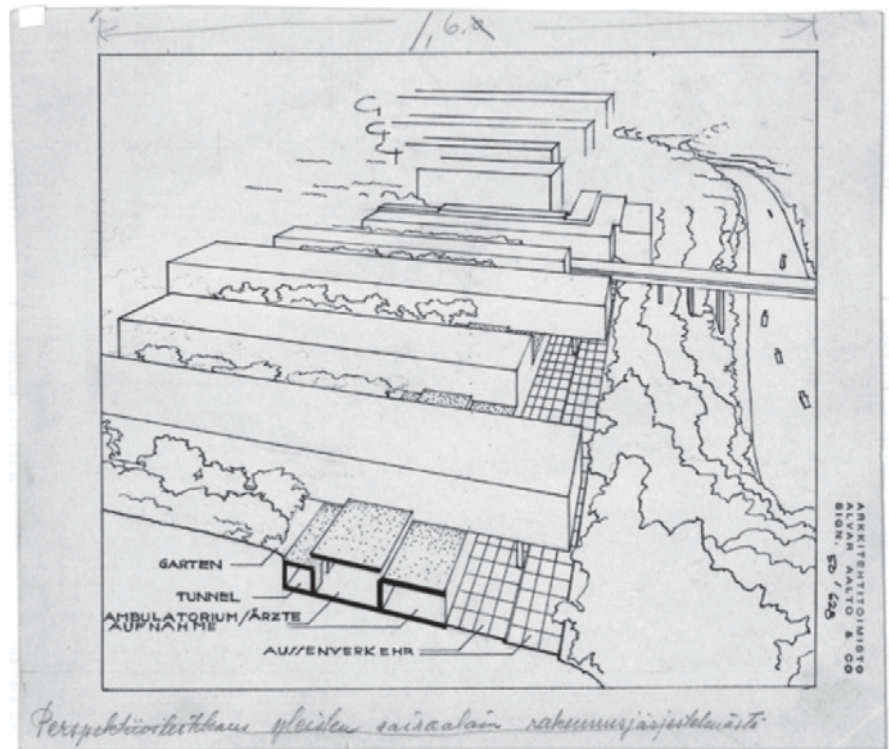

HG2

FIG HG1 –Site plan of the composition with marked zone of General-Foundation Hospital of the south of the hospital complex of Zagreb, Aalto, source: AAA
FIG HG2 – Perspective drawing of the composition of the General-Foundation Hospital of Zagreb, Aalto, source: AAA

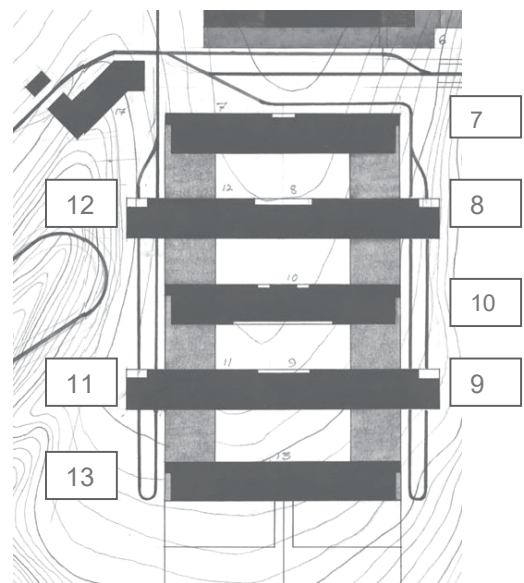

- 7** HOSPITAL SURGERY DEPARTMENT
- 8** HOSPITAL OTORHINOLARYNGOLOGY DEPARTMENT
- 9** HOSPITAL ORTHOPEDICS DEPARTMENT
- 10** HOSPITAL INTERNAL DEPARTMENT
- 11** HOSPITAL DEPARTMENT OF DERMATOVENEROLOGY
- 12** HOSPITAL DEPARTMENT OF OPHTHALMOLOGY
- 13** HOSPITAL NEUROPSYCHIATRIC DEPARTMENT

ZONE 2

FOUNDATION HOSPITAL

PRINCIPLE 6

"Backbone"

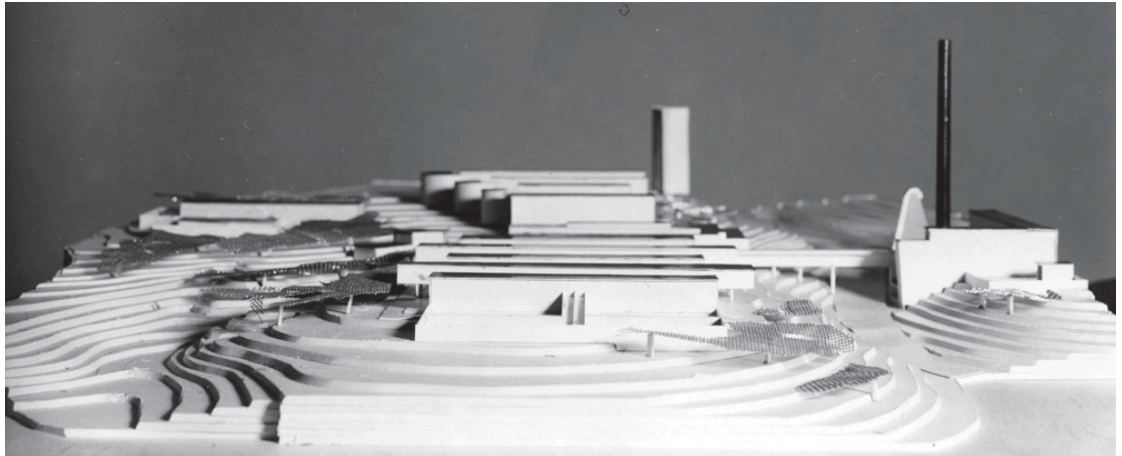

HG4

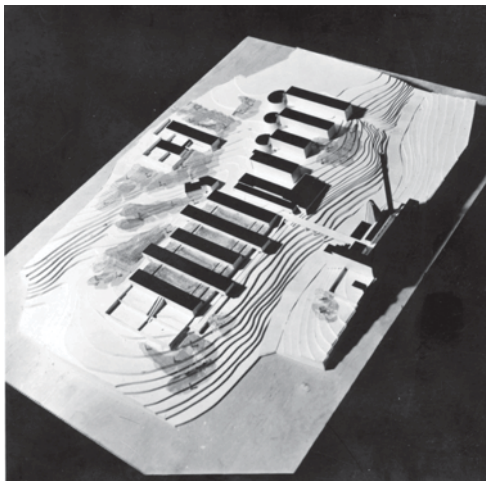

HG5a

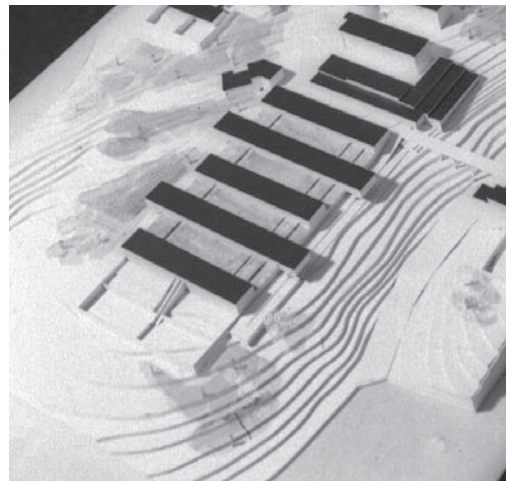

HG5b

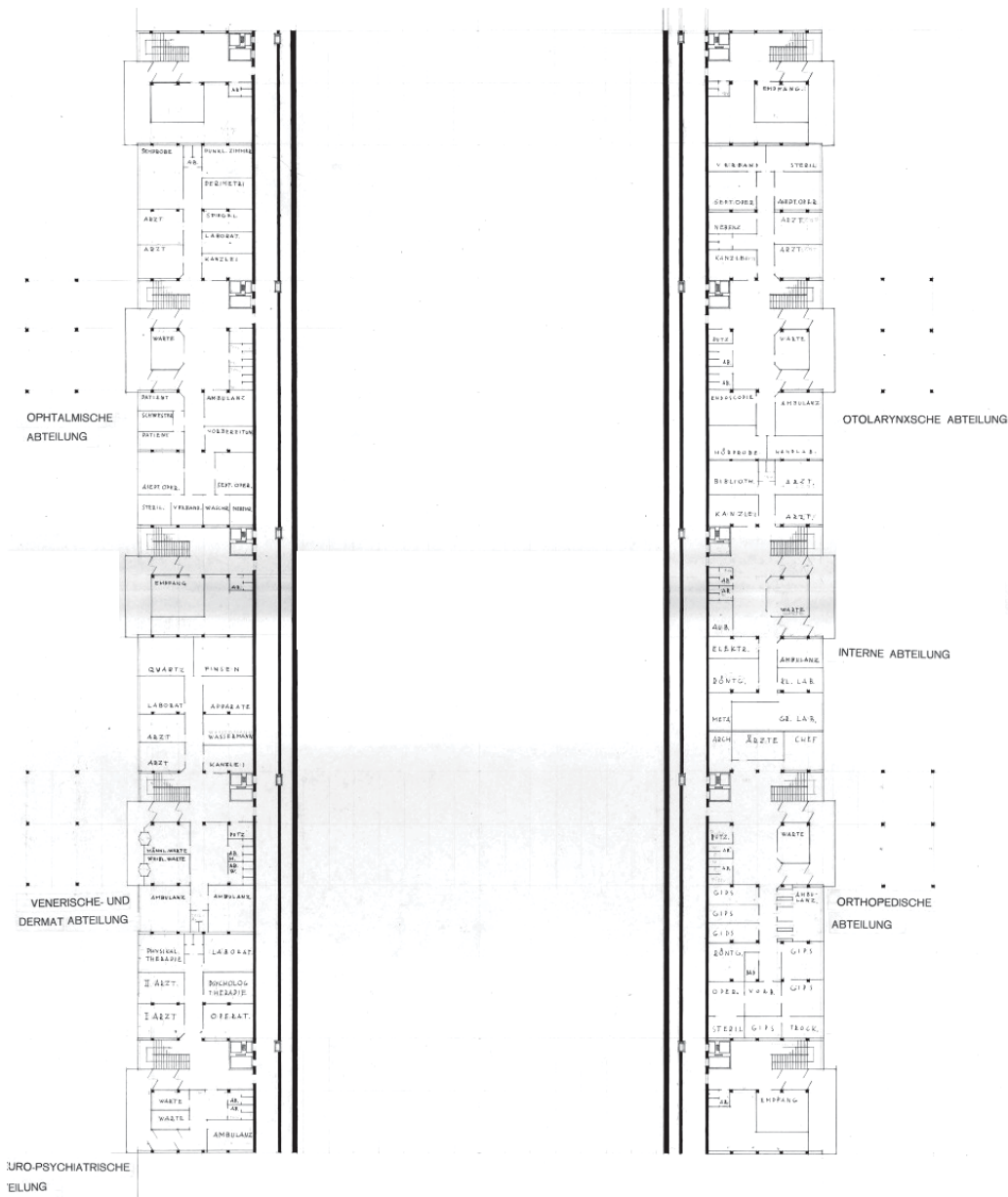

HG6

FIG HG 4,5a,b – Original model of the hospital complex and the Foundation Hospital of the south of HCZ, Aalto, source: AAA

FIG HG6 – Floor plans of the final drawings of the Foundation Hospital of HCZ (with 7 departments), Aalto, source: 50/621, AAA

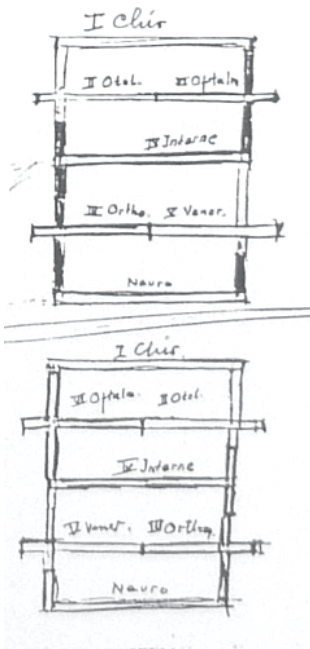

HG7a

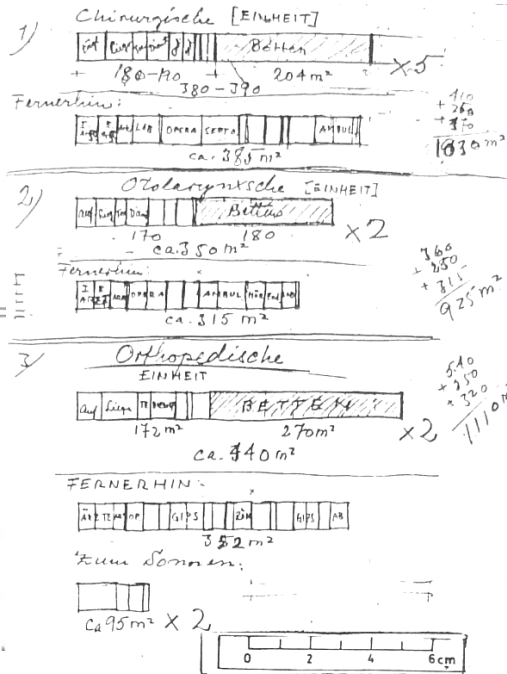

HG7b

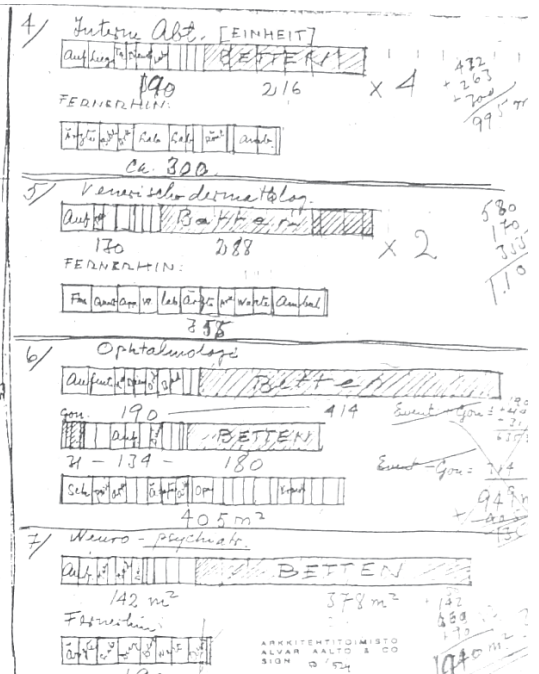

HG7c

FIG HG7a,7c—sketch of the Foundation-General Hospital complex with 7 clinics departments: order of the parallel pavilions from the program of the competition: list of the clinics (FIG HG7b) , from the necessary capacity of each clinic. Aalto developed one structure as "vertebrae" on the base of the two main tunnels (3 pavilions with the one clinics and two, each one with two clinics (with console), source: AAA

FIG HG7b – Aalto's schemes of the capacity of each clinic of the Hospital (7 clinics) program of the competition: list of the clinics, source: AAA

FIG HG8a,b,c – 3-D model of the composition of the whole complex as "vertebrae"/ backbone, especially structure of the Foundation Hospital with 7 clinics

FIG HG9a,b—Early sketch of the composition of the all complex and the Foundation Hospital of Zagreb (with 7 clinic departments), Aalto, source: AAA

FIG HG10—Early sketch of the composition of the Foundation Hospital of Zagreb (with 7 clinic departments and courtyards between them), Aalto, source: 50/600,AAA



HG8a,b,c

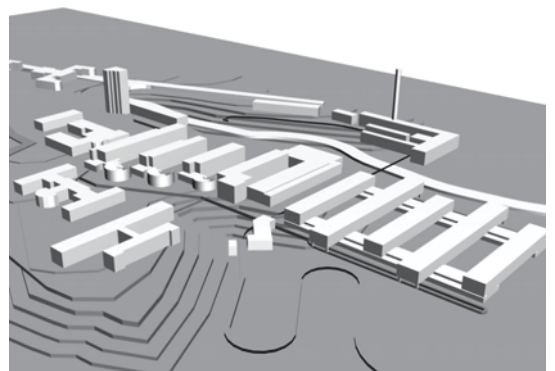
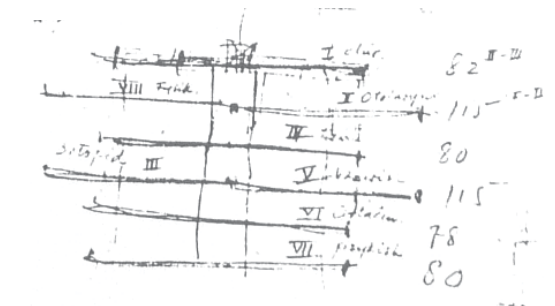

Aalto placed the Foundation Hospital in the south of the site (Fig HG 1-16) (this position also required the competition program), as one single continuous structure, "spine" with seven departments, as "vertebrae": Surgery, Otolaryngology, Orthopedics, Internal medicine, Dermatology and Venereology, Ophthalmology and Neuropsychiatry with 675 patient beds where Aalto respected the order of the clinics of the Foundation Hospital from the competition program and developed the composition by the five parallel clinic pavilions. He placed the Specialized Clinics with the School of Medicine in the north part and the Foundation Hospital with seven clinics in the south part of the complex where three departments are individual clinics and two larger parallel pavilions of the Foundation hospital contain four clinics (each pavilion two clinics).(Fig 7a,b,c) The Center of Radiology and Physiotherapy had the central position of the complex connected with both parts.

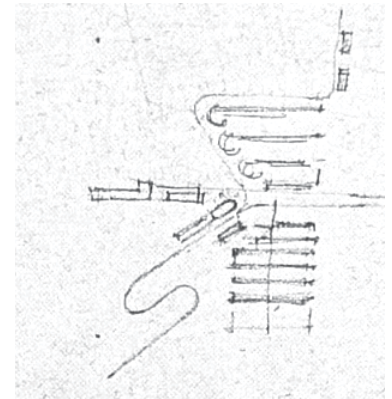

Aalto described the composition of this part of the Foundation Hospital²: *Each hospital department is designed in the way that all patient rooms are oriented to the south, to a quiet garden placed between departments of the Foundation Hospital. The flat-scheme of the building complex is composed as "two successive building systems": Ground floor has the North-South direction and contains clinical, surgical and medical spaces, as well as those spaces which are common spaces between the two connected hospital clinics. The upper floors have the West – East direction and there are placed patient rooms. A consequence of this transversal position between the ground floor and the upper floors (by exploiting the convexity of terrain with underground routes) are grouped, in enclosed protected areas, green gardens carried out on the roof level of the ground floor, separating the upper floors of the hospital parallel clinics. Any conflict is avoided between the different types of the traffic (and also the traffic outside the tunnel), even where tunnels traffic passed in the same plane, always runs in parallel and direct to the elevators and lobby. This system affected only partially the north part of the University Clinics. The windows extend up over the room ceiling. For this reason, the form of the building is selected based on the central construction corridor system with 3-4 m deep rooms, which are, separated by glass walls from the hall, located in the north of the buildings of clinics. By applying these principles, some of the patient rooms could be made deeper.*³

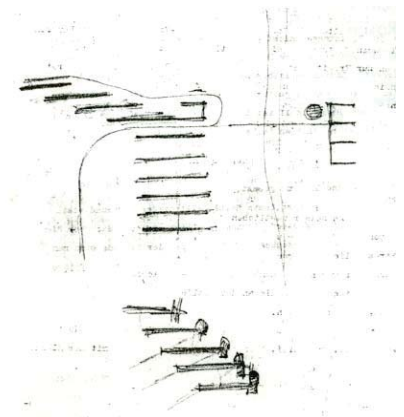

HG9a,b

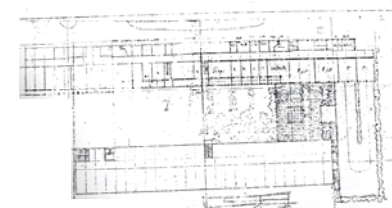

HG10

² Aalto Alvar, "Tävlingsprojekt till sjukhuskomplex", Arkkitehti, Helsinki, XII, 1932, p. 5-6

³ This is the one part of the description of the Aalto's original text about the competition (here in the text of the thesis was used just partial own translations of some relevant parts for the analysis)

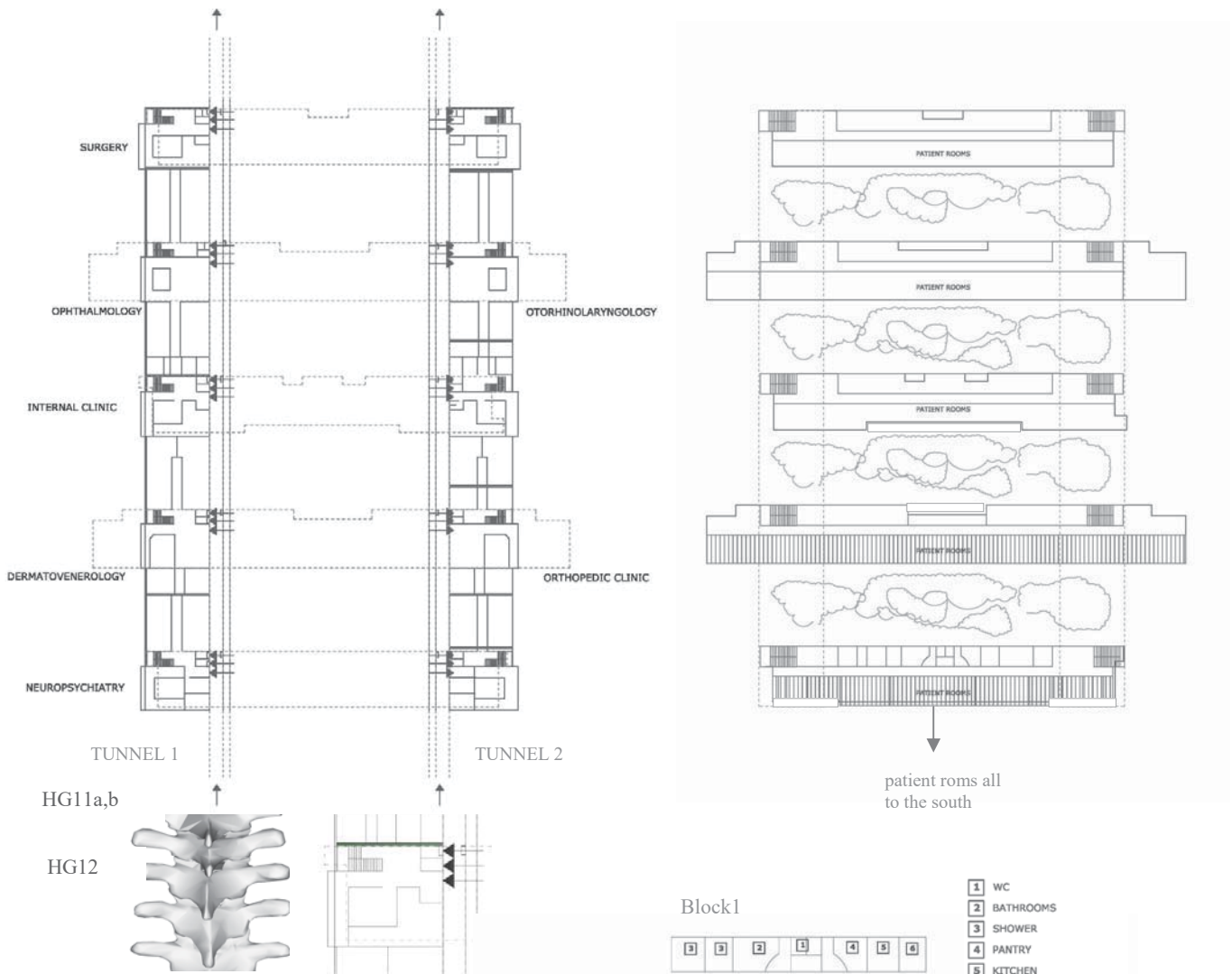
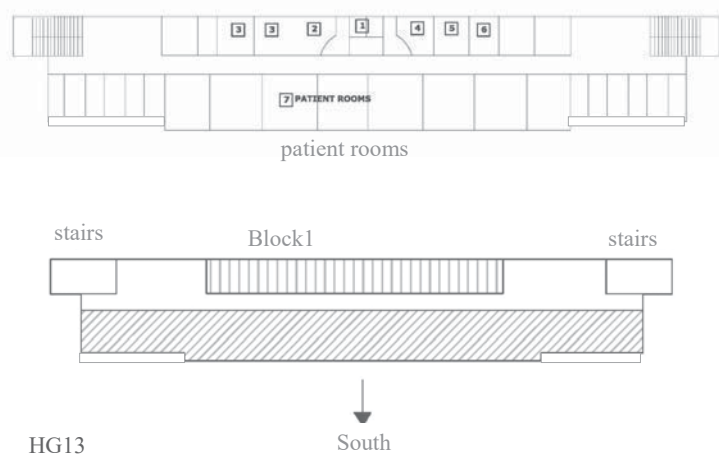

FIG 11a,b – Re-elaboration of the Aalto’s drawings of the Foundation Hospital , floor plants, ground floor (a) and first floor (b), source: author
FIG 12 –segment of the “backbone” of the human (show irregular shapes of the “vertebrae”, organic, not “hard line” shape of the modern movement. This irregular forms of the upper floors are results of the function (to give the best views and insolation of the central hall of the clinics, and the balconies of the Foundation Hospital. Genesis from the function to the form). Aalto’s “characteristic” unfinished shapes

FIG HG13– Re-elaboration of the one typical clinic department of the Foundation Hospital of Zagreb (example of the last department on the south of the composition: Neuropsychiatry). All rooms are oriented to the South (and in the same time the center of the city) and between all departments are placed green zones courtyards

FIG HG14 – Perspective drawing of the composition of the Foundation Hospital of Zagreb, Aalto, source: AAA



HG13

Principle requirement of the program of the competition was to orient all patient rooms to the South, and the program contained two options for the general organization of the hospital complex: to develop as one building (mono-block) or by using the separate system of individual buildings. In the program are indicated zones of the clinics with the new School of Medicine in the north of the lot, where are located previously some old clinic buildings of the School of Medicine. The Foundation Hospital is planned in the South of the site, on the lower ground on the hillside, oriented towards the South and the city. Aalto in this complex of the General hospital (with seven clinics) applied one very original building system., where he used this hillside to connect the two main paths which with the naturally incrementing ground levels of the hill leading to underground tunnels and at the same time these two main corridors-tunnels formed the base-ground floor, of the all parallel clinic pavilions with patients and operating rooms of the upper floors (Fig HG11 a,b). This underground communication system extends through the entire hospital complex, connecting all buildings and facilitating the external and internal communication, establishing the fast and direct access from the main paths of the complex.

Aalto creates the private spaces within the public spaces, integrated with nature which will continue to use in almost all his buildings and the urban plans in the future projects. He stated (about the Otaniemi University campus composition): "*somewhere between absolute individualism and total collectivism, there must exist a happy medium*"... "I attempted to design a group of many small schools...so that the illusion of a small school is created."⁴

Each clinic had a view of the city center, while their own green spaces with the nature were coming into the rooms of patients. This gave a unique internal-external space of the composition. A lot of the hospital complex on the hill was very stretch and elongated with the main direction North-South and slopped in the same direction. Due to this configuration and lot limits, Aalto naturally created "*spatial organism*" as a "**backbone**" of the human scale formed by the individual parallel pavilions, taking advantage of this hilly configuration of the terrain. (Fig HG12 -15).

⁴ Aalto Alvar, "*Between Humanism and Materialism*", lecture given at the Central Union of Architects in Vienna, 1955

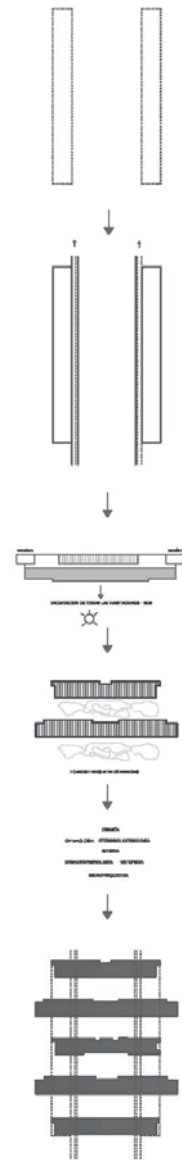
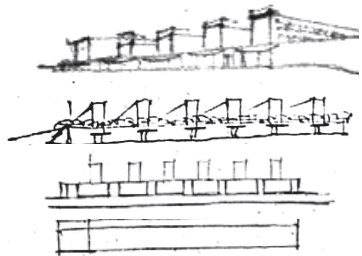
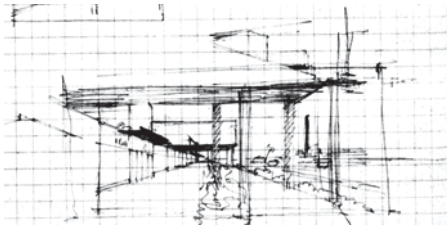
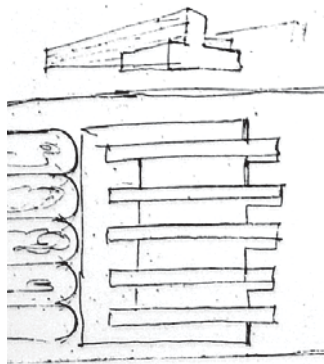

FIG HG14 –main elements of the composition of the Foundation Hospital: 2 tunnels as the b main routs of the complex, one part underground as the basis of the parallel individual pavilions of the departments of the Foundation Hospital, insolation from the south and green zones.



HG15



HG16

FIG HG15 - Early drawings of the composition of the Foundation Hospital of Zagreb, Aalto, source: AAA
FIG HG16 - Perspective drawing of the composition of the Foundation Hospital of Zagreb, sketch of the entrance to the departments in the ground plan and the pavilions of the first plan above as marquee Aalto, AAA
FIG HG17 - Drawing of the plan for the Seventh Centenary Exhibition in Turku (Erik Bryggman), 1929, source: Dominguez, 2003 (Similar system of the temporary rectangular pavilions of the exhibition placed on the flat part of the hilly terrain. Also this positions of the pavilions are relate with the limits of the site, main routes position of the exhibition, "Z"). This composition of the site of Turku Exhibition was observed Aalto, but we can not confirm his collaboration on this plan of the whole complex of the Exhibition, because almost all drawings of the whole complex are with signature of Erik Bryggman, but it is sure that influenced the composition of this Zagreb hospital complex of the Aalto's proposal.

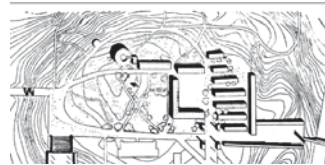

HG17



HG18

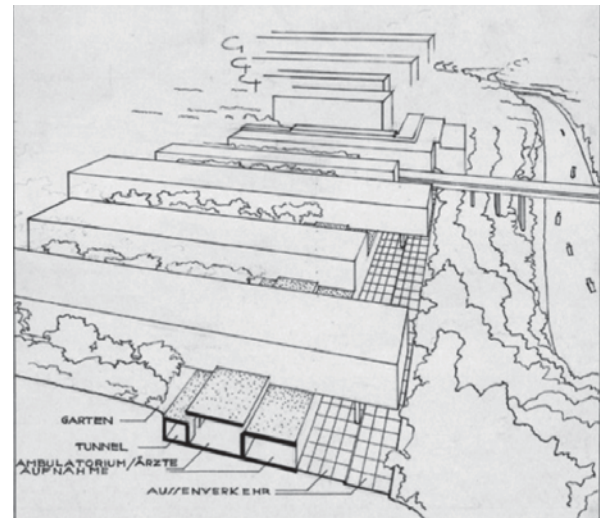

HG19

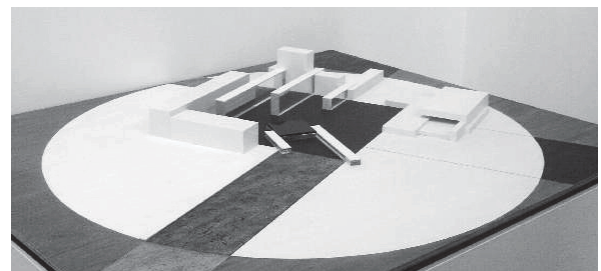

HG20

In this composition of the pavilions, Aalto respected all Functionalism postulates, orthogonal system of the pavilions, providing the best insolation and ventilation, but if we analyze shapes of the parallel pavilions of the upper floors, from the plan of the whole complex with all sketches of the General hospital, we can find metaphorical shapes of "vertebrae" - "**backbone**", following the functions of each department of the hospital, characterized by "unfinished form" - typical of many future projects. Aalto using this system which proves the best orientation of the patient rooms to the South and with a view and access to the terraces and green, peaceful gardens between the parallels buildings of the different clinics.

Different size and forms of the "vertebrae" of the backbone are not pure rectangular forms of the parallels pavilions as the "hard line" of the modern movements, but an organic structure representing that nothing is perfect and completely finished in organic, natural world. This aspect of the "unfinished" discontinuity form of the parallel clinics of the Foundation Hospital Aalto developed for the practical reason of the central hall insolation of the floors of the hospital. He made this discontinuity just on the north part of the façade and provided the continuity of all patient rooms oriented to the South. (Fig H11-16).

By analyzing this composition of "backbone" we can sense a strong influence of the logic simple construction of the primitive architecture of the stone blocks, as the composition made by megaliths (Stonehenge) (Fig 18a,b), one big horizontal stone block on the two supports, in this case of the Aalto's proposal, two tunnels as the supports and big horizontal block of the hospital rooms of the different clinics. (Fig HG 19) Bauhaus school and Bauhaus masters houses (1926) by Walter Gropius have the similar composition of the two perpendicular directions of the ground rectangular floor as a base and the first floor above laterally, and also this composition draws its origins from the Russian Constructivism and "Hard Line" of Modern Movement, but with incorporated at the same time elements of Aalto's "own organic" bio-morphological architectural language. Aalto believed in the architecture origins and "crystallization" of the architectural idea in the arts. On this "backbone composition" we can find one significant influence of the geometry and "juxtaposition" collage from the Suprematism of Kazimir Malevich and his series of Dynamic Suprematism and also from Lisitzky series "Prouns" (Fig HG20), and his numerous exhibition displays and marketing works (Soviet pavilion at the "Pressa" exhibition in Cologne, in 1928, for the Soviet Union). (Fig HG 21)

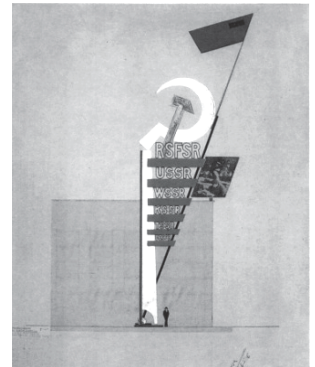

HG21

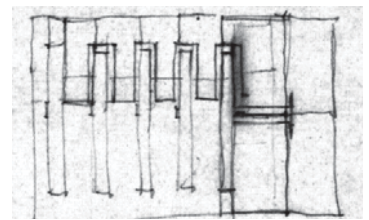
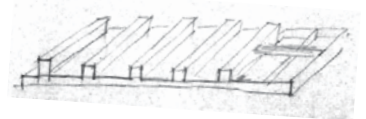

HG22a,b

FIG HG18– Stonehenge, source: <https://es.wikipedia.org/wiki/Stonehenge>, visited 6.03.2015

FIG HG19 – axonometric drawing of the Foundation hospital structure with seven clinics, for the competition entry of Zagreb, Aalto, 1930-31, source: AAA

FIG HG20– Lisitzky, series "Proun", 1e miasto 1921- model, <http://architektonator.blogspot.com.es/2013/04/el-lissitzky-architekt-prouny.html>, visited 6.03.2015

FIG HG21 - soviet pavilion at the "Pressa" exhibition in Cologne, 1928, Lisitzky, source : <http://thecharnelhouse.org/2014/03/01/el-lissitzkys-soviet-pavilion-at-the-pressa-exhibition-in-cologne-1928/>, visited 06.04.2014

FIG HG22a,b – Early sketches of the composition of Foundation Hospital, of Zagreb, Aalto, 1930, source: AAA

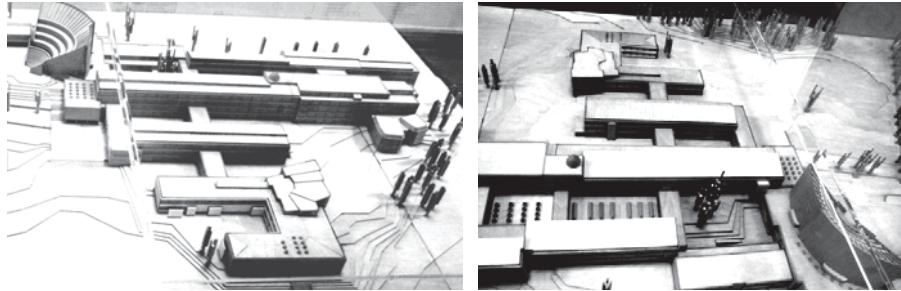

HG 23

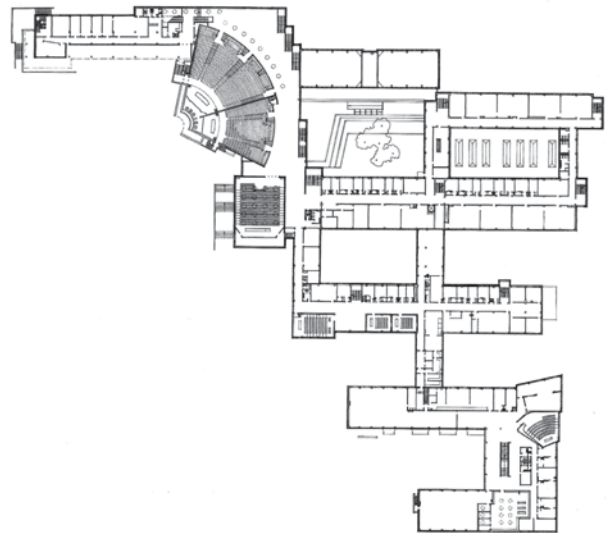

HG 24

FIG HG23 – Model of the main building of the University of Technology, Otaniemi, 1949-1965 , Aalto (model situated inside the building)

FIG HG24 -Ground floor plan (the main building of Otaniemi (situated inside the University, Otaniemi, Finland) source: Fleig K., 1995

FIG HG25 – Photo of the City Hall of Jyväskylä , 1964-72, Aalto

FIG HG 26 – Early drawing of the composition “backbone” of the Foundation Hospital with 7 clinics, Zagreb competition entry, Aalto, 1930, AAA

FIG HG27 –Floor plan, City Hall of Jyväskylä , 1964-72, Aalto, AAA

HG 25

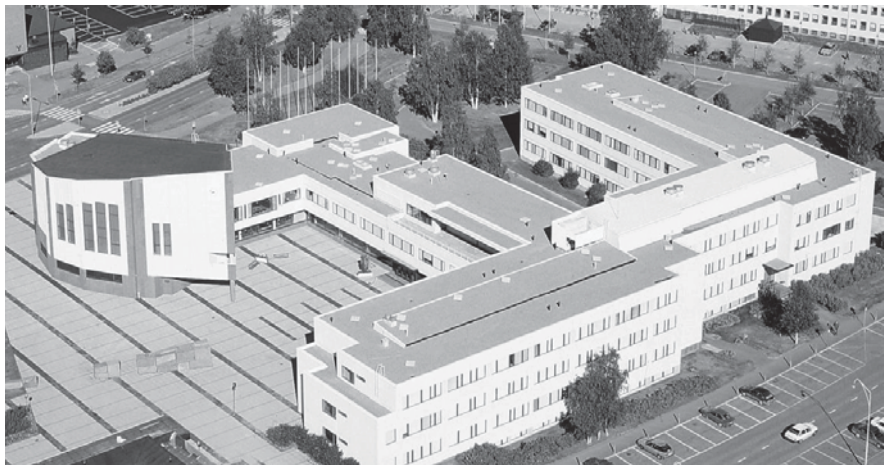

This composition of the South of the complex has some special connection with a series: "Proun"⁵ ("project for the affirmation of the new"). Moreover, we can observe the whole hospital complex composition, analogous to the artistic compositions of Suprematism or Proun of Lissitzky.

One year before this competition Aalto collaborated on some parts of the one project by Erik Bryggman for the Turku Exhibition plan for the 700. Anniversary, which is based also on the composition of the individual parallels exhibition pavilions placed on the similar terrain on the flat stretch part of the hill, and we can observe that project implemented the pure Functionalism forms and compositions. It was last experience where he collaborated on some parts of this project, as the open-air stage or marketing design to this exhibition (on the other plans of the Turku Exhibition complex, it is observed only the signature of Erik Bryggman and we don't know if Aalto collaborated also on the urban planning with the parallel pavilions), but he analyzing these plans of Turku where we find many similarities with the HCZ competition. The composition has the other, more complex reasons for existence, where becomes another structure, more organic. Moreover, this position of the pavilions was related to the limits of the site in both cases, in Turku exhibition all rectangular one-story pavilions are placed on the ground level, contrary to the Zagreb hospital complex composition which has the support of the other perpendicular system, below the parallel pavilions of the upper floors, which is the most important system of this composition of his competition entry, which make possible perfect underground circulation and integration of the whole complex with the nature, free of traffic. This "base" which green zones he applied as the "limits" of the site in the nature and, upper floors structure as the building on the ground. (this system as characteristic along his trajectory)

Christian Norberg Shulz, influenced by the philosophy of Martin Heidegger, treats two main characteristics which contain the place: 1. "space" (three dimensional organization) and 2. "character" (atmosphere of the place, the spirit, sense of place which Norberg Shulz calls Genius Loci. Built environment contains: centre, path and domain. Norberg Shulz, in the example of the project between the "local" and "general" takes the case of the main building of the University complex of Otaniemi (1949-1964) and accepts the Aalto "transform of the general openness of modern space into complex organism".

⁵ "Proun" is an acronym in Russian invented by Lissitzky, translating as "project for the affirmation of the new". Lissitzky began the *Proun* series in the late 1910s and continued to work on it into the first half of the 1920s.

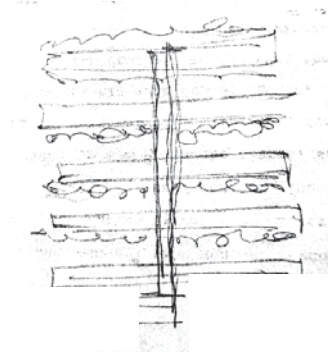

HG 26

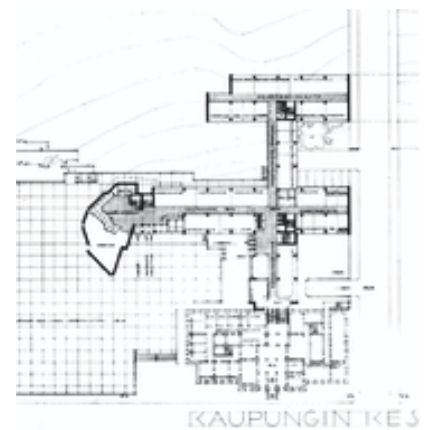

HG 27

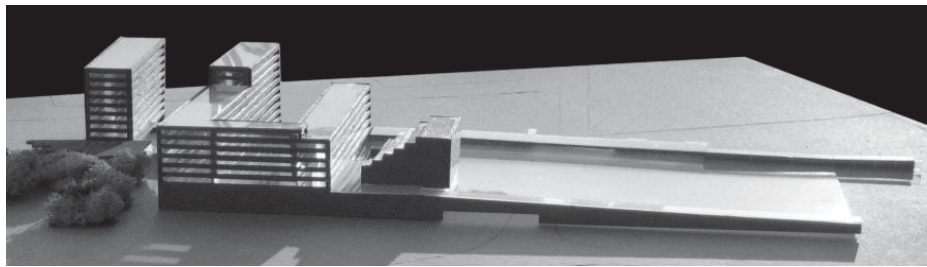
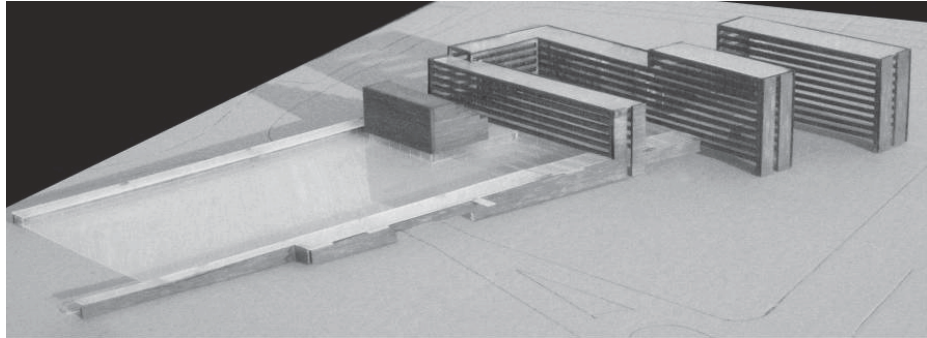

HG 28 a,b

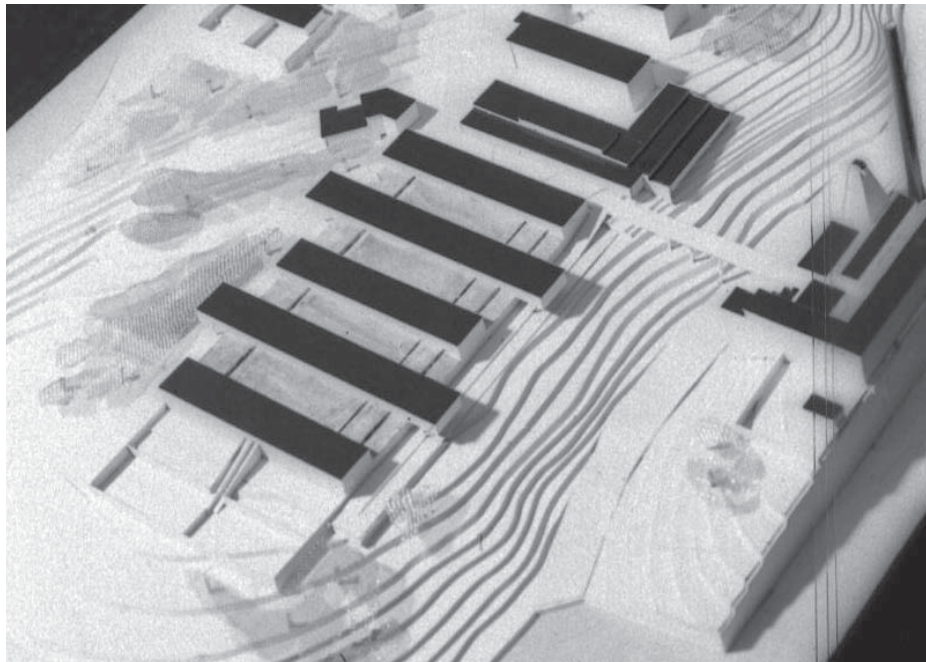

HG 29

In the main building of the University of Technology in Otaniemi Aalto formed "backbone" orthogonal composition which contains the individual parallel pavilions, departments of the University in this case (Fig HG 23-24), but with the same logic of including the green courtyards between the departments providing the best orientation for insolation and ventilation with clear views of the peaceful gardens. (Fig HG 26) Along his complete trajectory Aalto used many ideas and principles emerging out of HCZ competition entry as the associations from the interactive memory and the "universal substance" which give the balance and solutions for the many requirements of the program and conflicts. Aalto applied a similar system of the parallel pavilions of the City Hall complex of Jyvaskyla (1964-72) organized as one "spatial organism"(HG27). Pedestrian areas with green zones between these pavilions are often designed with the connection to the perpendicular based ground floor. In this project, he considered the correct orthogonal system emerging from the beginning of his career by implementing the ideas of Functionalism, with the new forms of the auditorium of the city hall. This system as the spatial organism and the "spine" with the parallel "vertebrae" of the composition Aalto applied on the one very similar way on the Competition for Municipal offices and city hall in Gothenburg, Sweden (1955). Aalto won the first prize with his entry "Curia". It was one vast complex where main task was to plan office spaces for the city administration and town hall. On both projects he used a similar system of the composition as vertebrae and "backbone" where are possible also future extensions. We can find the similar organization of the both competition projects, applied in the two completely different contexts, on the almost flat terrain in the case of Gothenburg and at the sloped hillside in the case of Zagreb. (Fig HG 28,30).

On both projects, Aalto made the similar composition of the two subway routes as the base of the parallels of vertebrae. Also in Gothenburg project formed the zone free of the motor traffic, establishing the promenade deck with two sides for this competition entry (Fig 29). In the front of the "backbone composition", Aalto planned the "city hall" as a part of "Ziggurat"– town hall of Gothenburg, in accordance with the Center of Radiology and Physiotherapy of the HCZ complex (with the central position, next to the Foundation Hospital in the project of Zagreb), another similar element in both compositions, but in the case of Zagreb, an inspiration for the stepped composition came directly from the configuration of the hilly terrain (stepped "L" composition of Radiology and Physiotherapy). Similar "backbone" composition of the orthogonal system with parallel pavilions he applied also in the project of the Johnson Institute in Avesta (1944) (Fig HG31), and in many other future works as the partial or main compositional systems with different uses.



HG 30

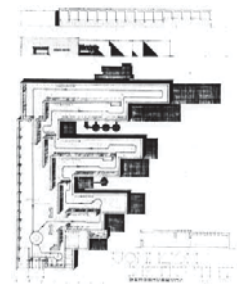

HG 31

FIG 28a,b – Model of the Gothenburg Municipal office and city hall (1955), Aalto.

(Photo source: Alvarez F., 2010: 312, department of History and composition of Architecture, UPC)

FIG 29 – Original model of all hospital complex and Foundation Hospital of the south of the hospital complex of Zagreb, Aalto, AAA

FIG 30 – Urban composition, axonometric drawing of Gothenburg Municipal offices and city hall, Aalto, sources: AAA (Schildt, 1994:130)

FIG - Johnson Institute, Avesta, 1944 ,Schildt , 1994 :)(AAA) (segment)

"The word stand denotes the relationship to the earth. Rise the relationship to the sky. Standing is embodied through treatment of the base and the wall. Some buildings are "ground-hugging", others rise freely, and in others again we find a meaningful equilibrium"... "Flat or sloping roofs, gables, domes and pointed spires express different relations to earth and sky"¹

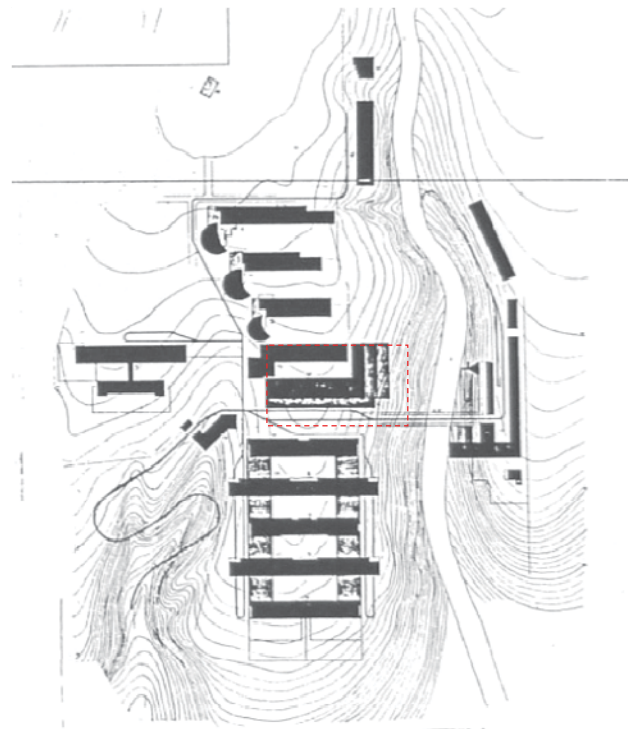

R1a

ZONE 3

CENTER OF RADIOLOGY AND PHYSIOTHERAPY

¹ Schulz Norberg, *"Genius Loci: Towards a Phenomenology of Architecture"*, Rizzoli, New York, 1980, p 66-67

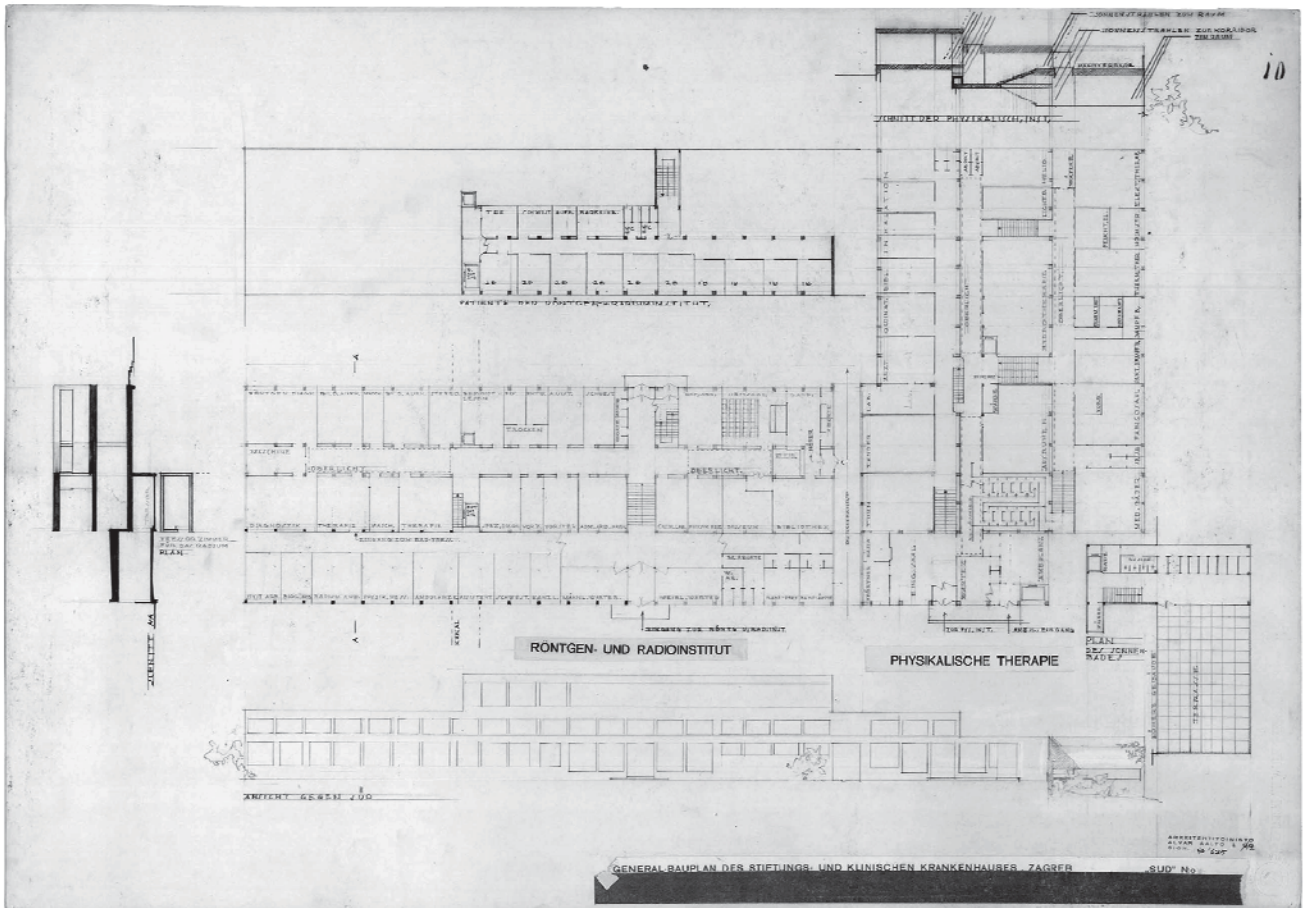

R1b

FIG R1a – Situation: Urban, composition plan of the competition entry for the hospital complex of Zagreb, Aalto, 1930/31, 50/610, AAA. Marked with the rectangle the zone of the Center of Radiology and Physiotherapy.

FIG R1b – Final drawing, Ground floor plan and sections of the Radiology and Physiotherapy Center of the competition entry for the hospital complex Zagreb, Aalto, 1930/31, 50/625, AAA.

FIG R1c - Scheme of the whole complex and central position of the Center of Radiology and Physiotherapy.

FIG R1d – Scheme of the underground connections between the Center of Radiology and Physiotherapy and the all buildings.

According to Steven Holl: *"the relation between things is the focus, rather than the object-type. The zero point of such a relation is a section at the surface of the earth"*.² The "Y" House, Catskills Mountains, NY (1997-99) confirm his theory: *"the house occupies the hill and the site through three primary relationships: in the ground, on the ground, and over the ground. The portion over the ground is suspended, cantilevered above the portion in the ground"*.³

The "Ground" has the widest meaning, as the synthesis of the architectural process of the modifications, which includes both: transformed terrain and the building on them, together observed as the one natural part of the hillside. That natural urbanism on the hill for Aalto it is the most beautiful which could be observed on the ground.

Aalto planned the Clinic of Rehabilitation and Physical Therapy, as the central part of the complex (required in the competition program), between both parts of the complex: Hospital General and Clinics (Fig R1a,b,c). Their compositions represent the dialogue between the man and the environment, where nature is penetrating into the space for rehabilitation and physiotherapy of the patients. He developed in this project one composition as a "leitmotif " of many later projects of the "stepped architecture" (with the natural "sloped" and flat ground base).

In the competition program is written that for the Center of Radiology (Fig R2), requires to design terraces or balconies for the Rehabilitation open spaces and for staff exposed to radiology- x-rays and patients in order to provide the best insolation and ventilation. For that reason, Aalto developed this stepped composition of the Clinic of Rehabilitation and Physical Therapy on the sloped ground with the "cascades" in the vertical plane of the section and the façade, and on that way, he allows the light into clinic spaces, with large windows transparent facades.(Fig R3,4)

Main facades and spacious terraces of the Radiology and Physiotherapy center have the best East and South orientations. In this stepped composition at the hillside, the terraces are formed as the major elements for integrating the interior clinic space of Rehabilitation with Nature as the exterior-interior space without limits.

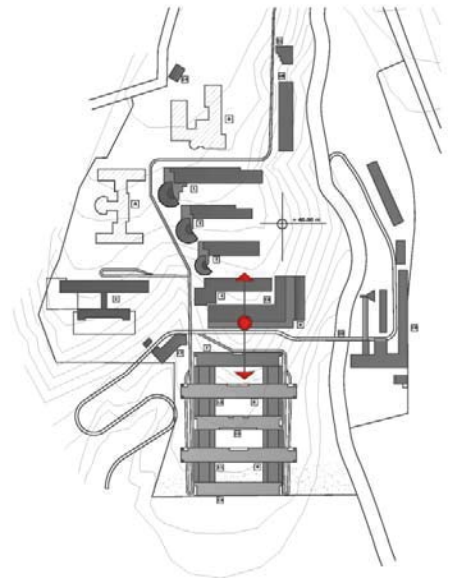

R1c

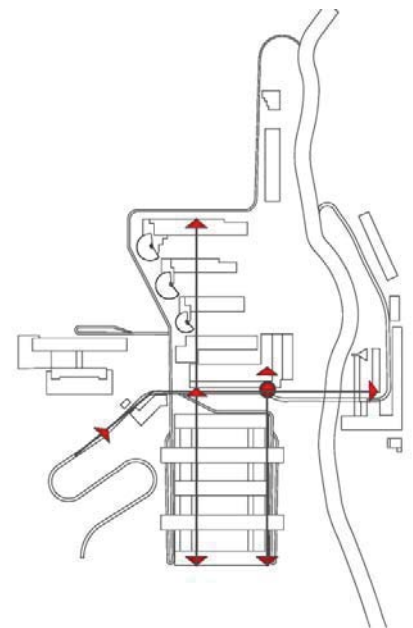

R1d

² Holl Steven, *House: Black Swan Theory*, Princeton Architectural Press; 1 edition March 29, 2007, p.75

³ Ibid., p.75

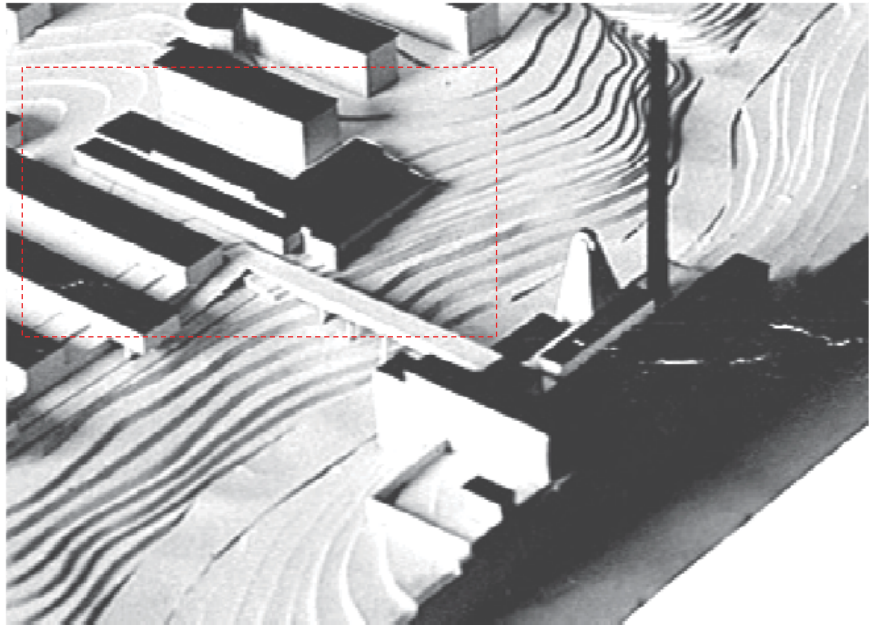

R2

FIG R2 - Original model of the complex of Zagreb 1930/31, Aalto, source;AAA(marked stepped composition of the Radiology and Physiotherapy center (zone 3) and Service Center on the other side of the road (zone 4) on the west side, on the north side clinics of the university of medicine and on the south side clinics departments of the general hospital

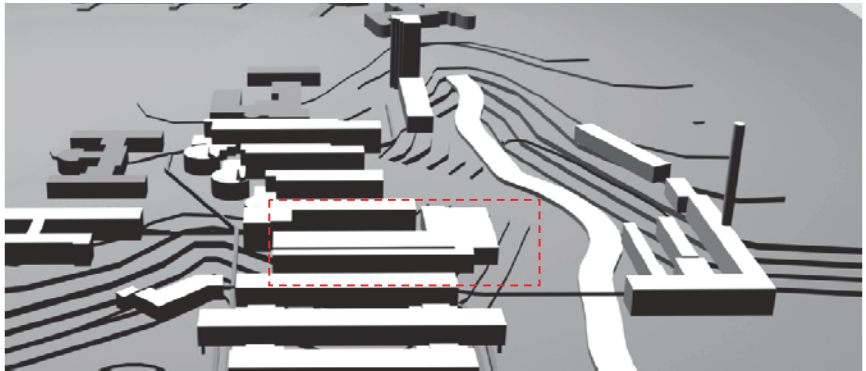

R3

FIG R3 -Segment of the 3d model, relation between two centers on the two hillsides of the Radiology and Physiotherapy center (zone 3) and Service Center on the other side of the road (zone 4) on the west side, on the north side clinics of the university of medicine and on the south side clinics departments of the general hospital

FIG R4-Section of the Radiology and Physiotherapy center of the Service part of the hospital complex Zagreb, Aalto, 1930/31, segment , source: 50/625,AAA (on this drawing could be observe the upper windows of the "cascade" sections, indirect daylight and some as the accesses to the terraces), segment,source: 50/625,AAA

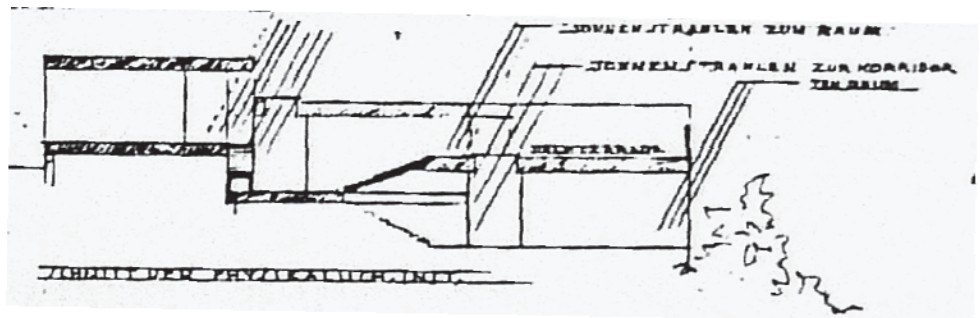

R4

FIG R5-Section of the Radiology and Physiotherapy center of the Service part of the hospital complex Zagreb, Aalto,1930/31,segment,source: 50/625, AAA

(stepped section and the underground tunnel connection source: A with whole complex So)

Aalto developed this composition following the topography of the land where the spaces have an advantage of the insolation in the best way. He always wanted to accomplish the direct development of the human relation to a natural environment as the one "whole".

In this project is used a very original system of the underground tunnels as the main routes across the whole hospital complex providing the best communication between the clinics and the Center of Radiology and Rehabilitation. In this way he prevented any possible interference of the communications inside the complex: he protected the complex from the motor traffic because everything occurs underground. Two tunnels passed from both centers (Clinics and General Hospital) directly to the part of the Radiology as the community service and center of the whole hospital complex (one tunnel from the General hospital passed to the Physiotherapy Center, but connected with Radiology in the same complex and in that way with the Clinics of the North (R1d,5)). The sloped ground gave the opportunity to separate entrances for the different users of the two different parts of this Center of Radiology on the one side and Physiotherapy on the other side. For this reason, Aalto organized this part as the "L" composition between the main roots of the complex, where he created a metaphor of the Ancient "Ziggurat" of Mesopotamia with the stepped form of the both directions follow the configuration of the hillside.

Aalto organized the necessary spaces of the Radiology (radiology, radiography, outpatient units and others), and Physiotherapy (hydrotherapy inside the complex, thermotherapy, inhalations, helio and others (*view on the plan*)) in the three main blocks of the floor plan with two parallel hallways, both with skylights, where he take advantage of the sloped hillside as the "cascades" of the building complex of the one floor and where in the central part on the first floor of the Radiology center he developed the rooms of patients with the access to the big terraces on the highest level of the "ziggurat".

The developed the upper windows in the vertical plane for each of the three blocks of each block of the "L" composition. (R1b, R6) That's windows in the same time give the best insolation and protected from the direct view and they are, also, access to the terraces (roofs of the composition "cascades"). Aalto planned patient rooms with the terraces on the upper floors. (Fig R6-7). These terraces he designed for the Radiology Center staff providing the best ventilations as the best health protection.

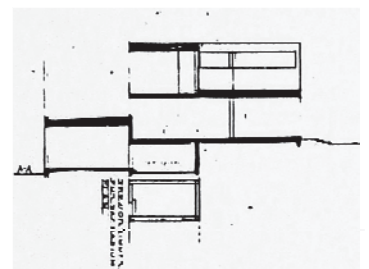

R5

The same terraces, on the other side of the "Ziggurat" composition, he developed for the Physiotherapy patients, as the best natural medicine. The similar stepped vertical plane with large terraces we can find on many of his projects, as the complex of the terraced houses in Kauttua (1937) or his Museum of Jyväskylä, Museum of Aalborg (Fig R8), Shiraz Museum and many other works analyzed in the part of the principle 7 – "Stepped vertical plane".

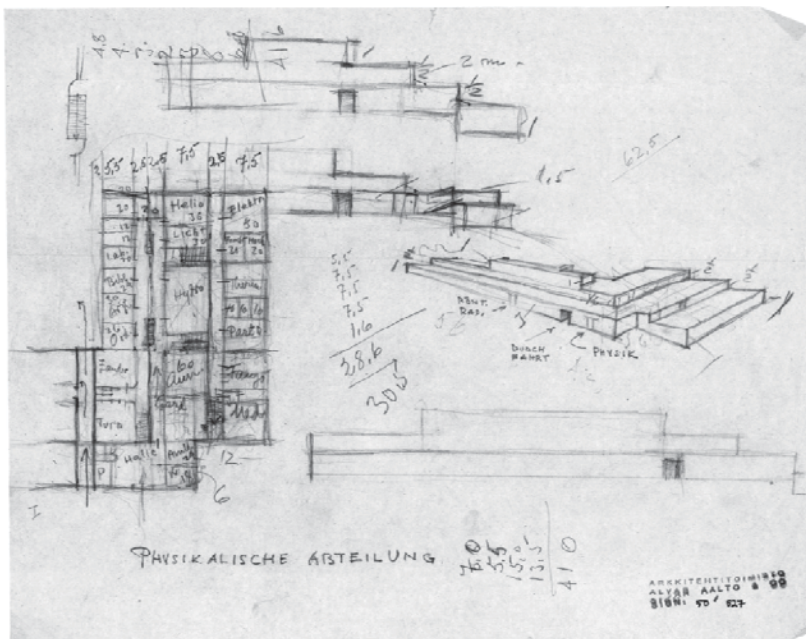

R6

FIG R6 – Sketches: sections, ground floor, axonometric sketches of the Radiology and Physiotherapy center of the hospital complex Zagreb, Aalto, 1930/31, 50/527AAA

FIG R7 – Axonometric drawing of the Radiology and Physiotherapy center of the hospital complex Zagreb, Aalto, 1930/31, segment 50/527, AAA (composition analogous to "Ziggurat" where is marked separated entrances by the tunnels, main paths of the complex)

FIG R8 - Sketch of the stepped façade (as a "ziggurat"), Museum de Alborg, Denmark, Aalto, 1958 source: AAA

R7

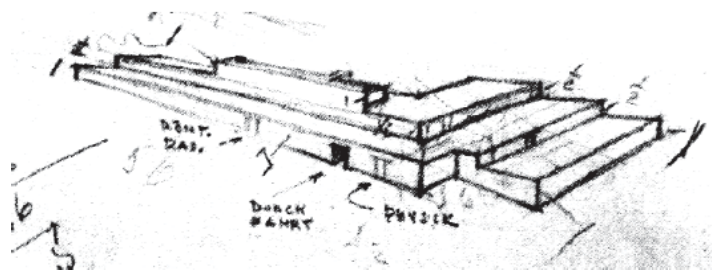

R8

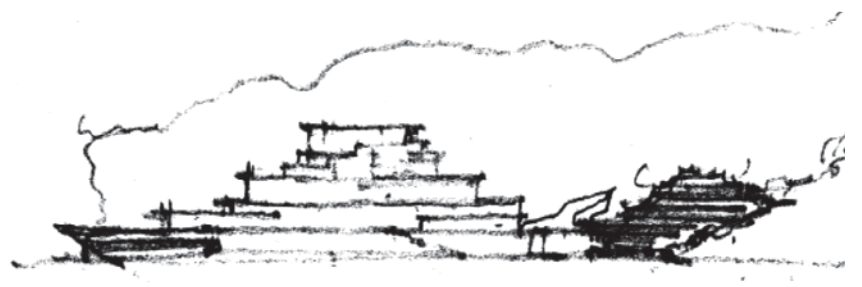

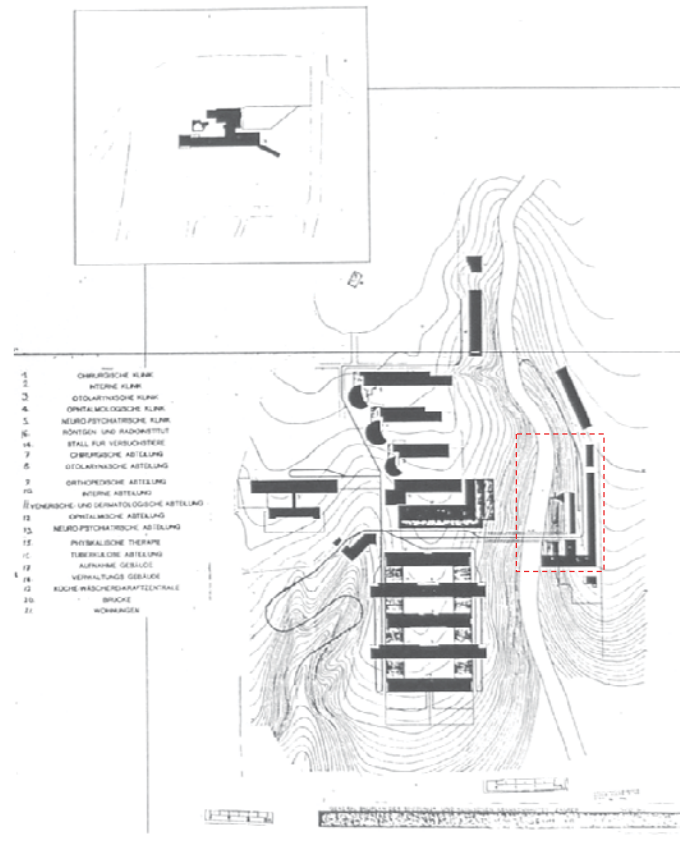
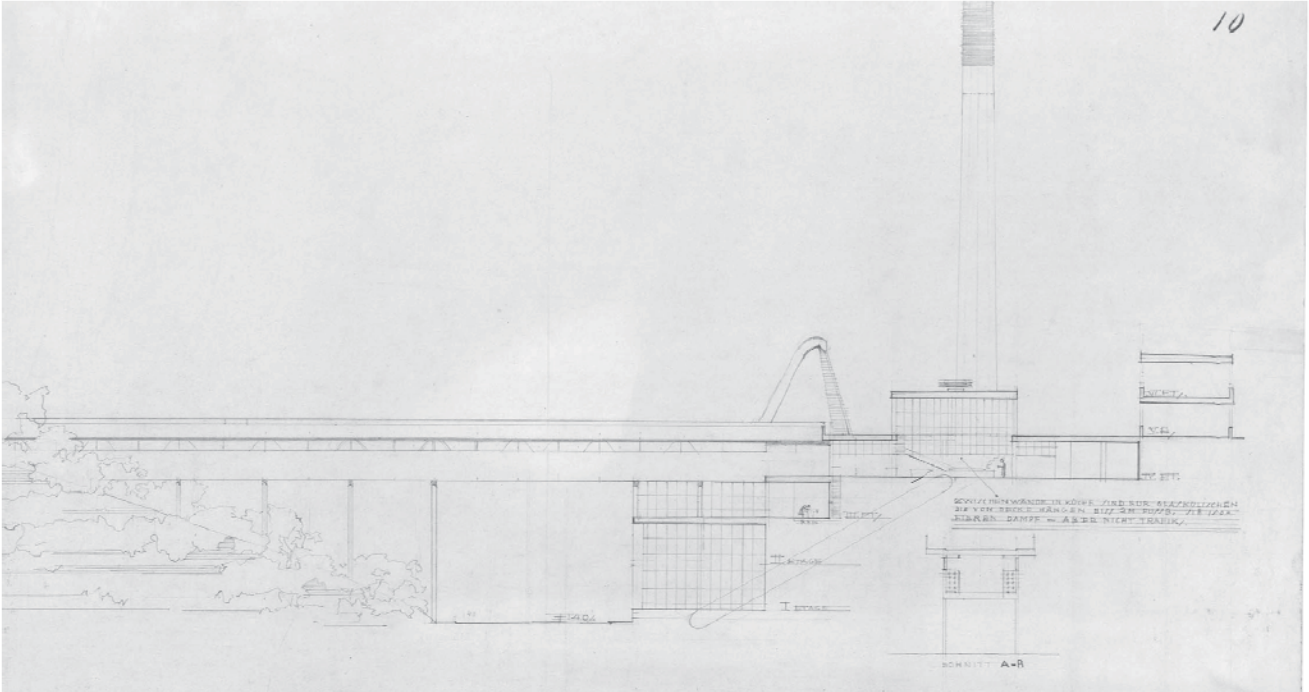

FIG S1- Situation: Urban composition plan of the hospital complex Zagreb, Aalto, 1930/31 , 50/610,AAA
 Marked with the rectangle the zone of the Service center (with the staff rooms)

ZONE 4

Service Center of the Complex



S2

FIG S2 –Façade and sections of the service complex of the HCZ (on the left side of the road and bridge connecting both parts of the complex), 1930/31 on the hillside and with the bridge –tunnel connecting with the other side of the road. 50/614,AAA(stepped composition follow the hillside configuration),

FIG S3.- First floor of the service complex of the HCZ (below the bridge boiler and heating plant spaces, power plant and engine rooms,, accumulator, transport for the kitchen and other upper spaces from the lower levels), 1930/31, 50/613,AAA

FIG S4 - Fourth floor plan of the service complex (on the left side of the bridge- washing center and on the right side kitchens and one part of the rooms for nurses on the limits of the complex , "80 % oriented to the south"(from description of Aalto), where program required these room in this part of the complex. Aalto developed the rooms for 120 nurses and 100 for the other staff of the service complex. , HCZ 1930/31, 50/612, AAA

FIG S5 - Upper floor plan of the Service part of the HCZ, Aalto, 1930/31, 50/611, AAA (on this floor plan we could see the position of the staff rooms on the last (vi) floor, and on the (v) level, chapel on the other side next to the service complex with the courtyards.

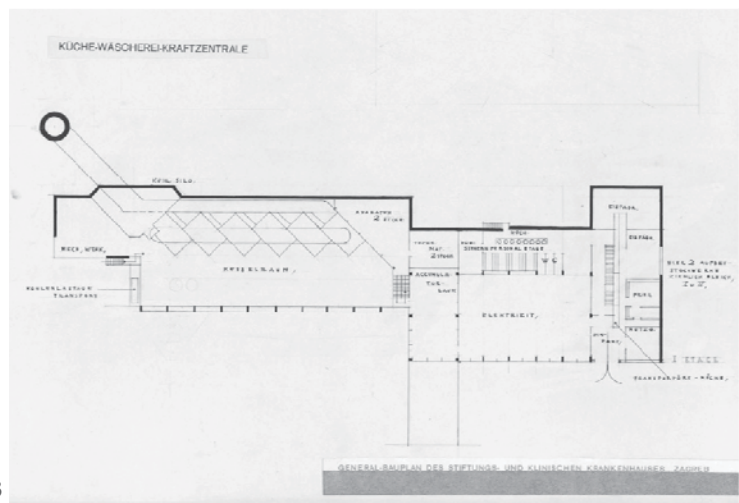

S3

KÜCHE-WÄSCHEREIKRAFTZENTRALE

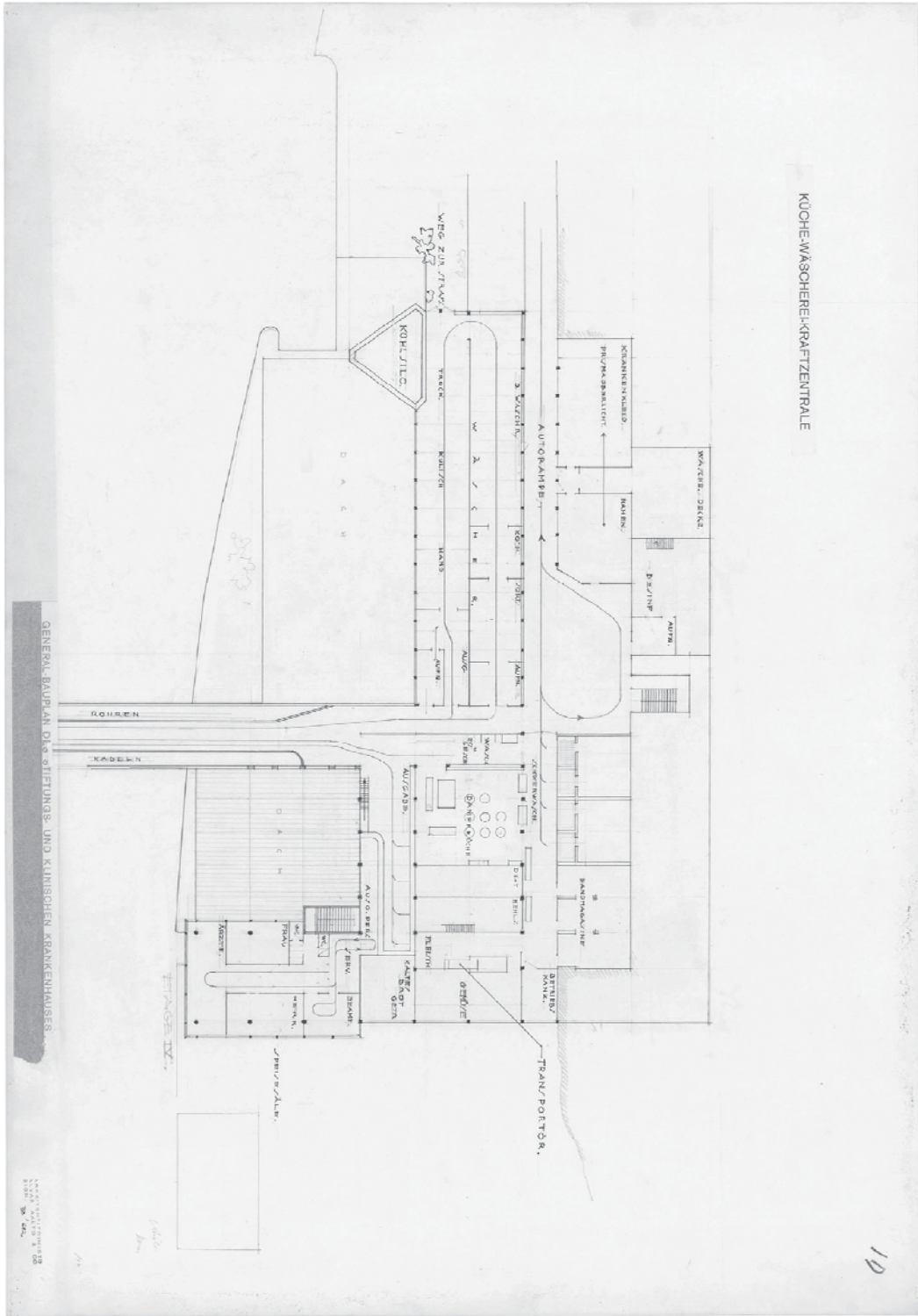

GENERALBAUPLAN DER STIFTUNGS- UND KLINISCHEN KRANKENHAUSE

1900

19

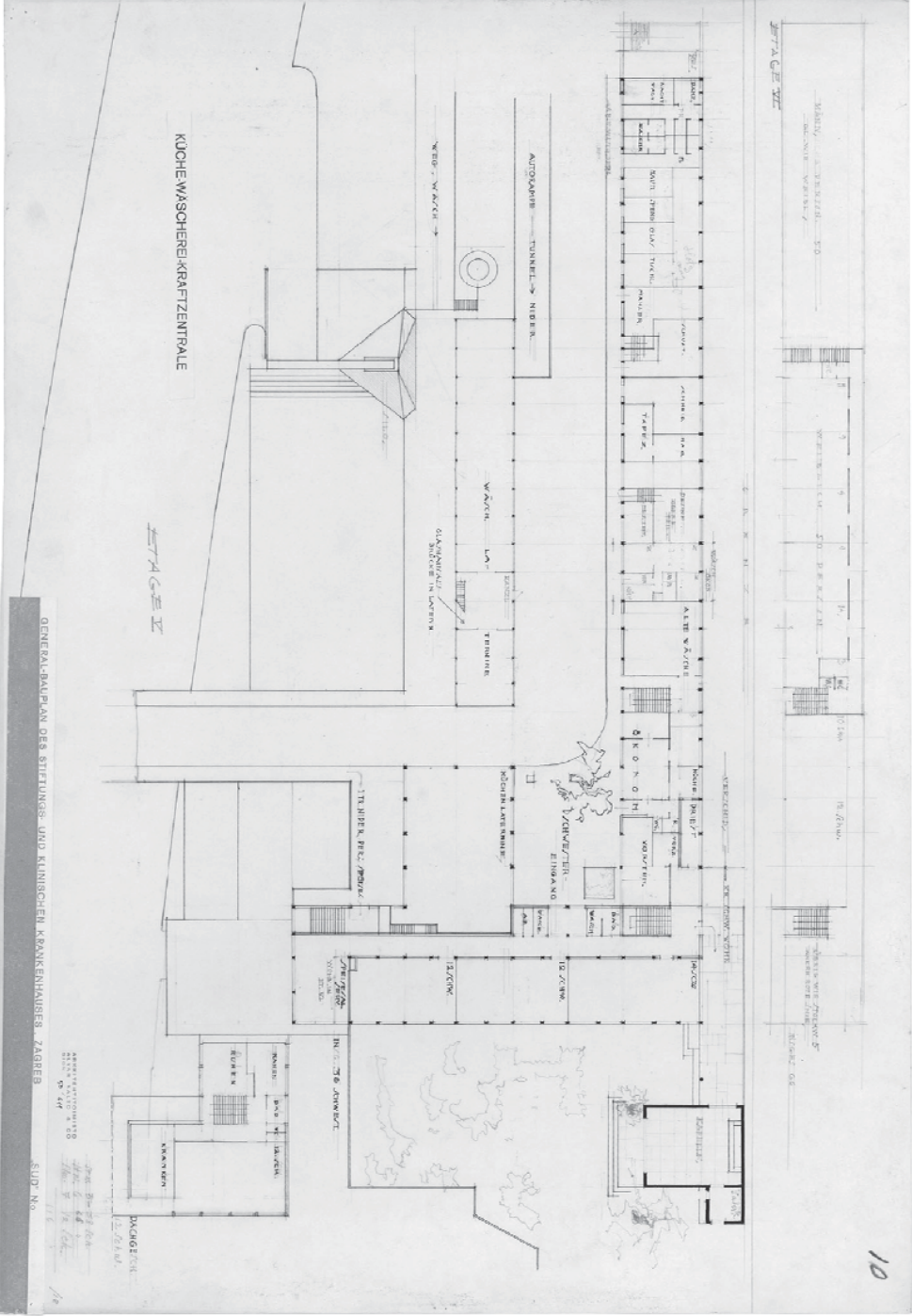

Aalto organized all service buildings of the hospital complex in the front of the building of the Radiology and Physiotherapy, on the other hillside of the main road, by the stepped composition, following the configuration of the very sloped hillside (Fig S2). This part of the terrain has been marked on the main map of the site, received with the competition program, which gave the two options to organize this service part of the complex. Because the difficult topography of the terrain with very sloped hillside (lot 2) in the program of the competition also existed the option to organize this service part of the complex together with the Hospital complex (lot 1). Aalto described his own idea of this part of the complex:

“The building is located on a steep slope and so the story was formed up and down the back of the program regulations. Directly connected with the tunnel level (Fig S2) are placed kitchen of the whole complex, laundry, disinfection and receipt of deposit of instruments. Connected with the tunnel side and below are located the power plant and engine rooms. (Fig S3) The kitchen and laundry are constructed so that there is the possibility of circulatory streamlined operation and rationalization of the use. (Fig S4) Living spaces of nurses: 80% oriented toward the south. In the quiet zone of the south they have a private garden with a chapel.”⁴(Fig S5)

Taking the advantage of the very sloped hillside, one part of this service complex he organized in an underground part following the configuration of the terrain. At the highest, V and VI floor, he organized the rooms for the employees of the complex on the north (for 100 persons) and the rooms for nurses (120 nurses), partially placed in the north of the complex oriented to the East and partially located on the east side on the limit of the service complex, next to the green zone oriented to the South. In this project, Aalto designed one bridge-tunnel connected to this zone, one closed structure of the two levels, planned as the direct communication with the underground tunnels of the lot 1 (hospital complex) above the valley between two hillsides. (Fig S6d, S7a) By this bridge passed hidden all installations: water, electricity and heating installations from the community service center for all hospital buildings situated on the other valley side. This bridge-tunnel provided the fast connection between the hospital complex and the service parts, central kitchen and washing, placed behind the tunnel in the service area, by the separated corridors.

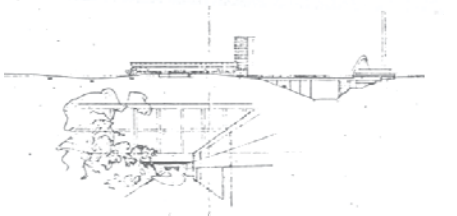
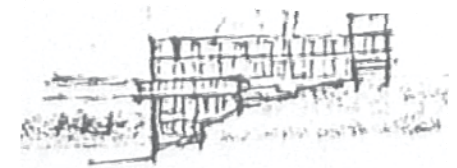
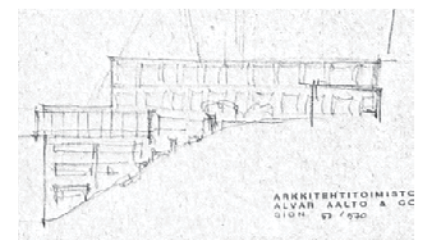
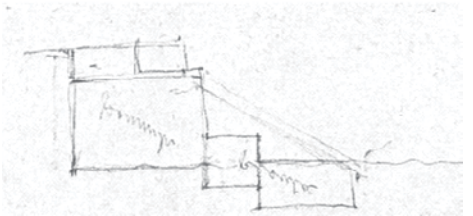

S6a,b,c,d

⁴ This description wrote by A.Aalto about his proposal for this competition entry

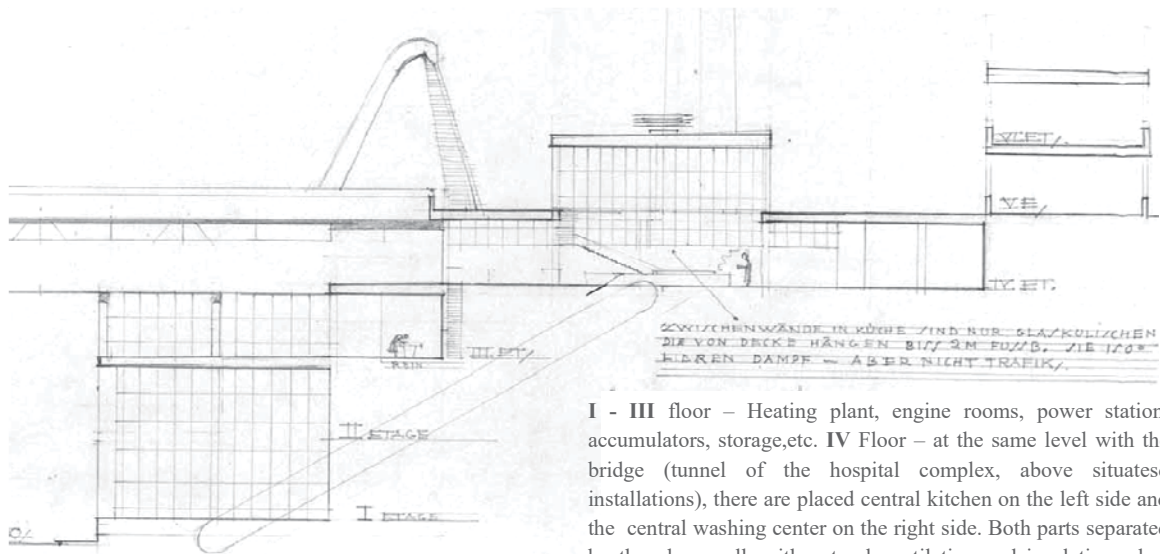

S7a

I - III floor – Heating plant, engine rooms, power station, accumulators, storage, etc. IV Floor – at the same level with the bridge (tunnel of the hospital complex, above situated installations), there are placed central kitchen on the left side and the central washing center on the right side. Both parts separated by the glass wall, with natural ventilation and insulation, also, one part of this services areas he planned in the underground level taking advantage of the sloped hillside. V and VI floor of the common spaces and rooms of the staff with the green courtyards and the chapel for the nurses.

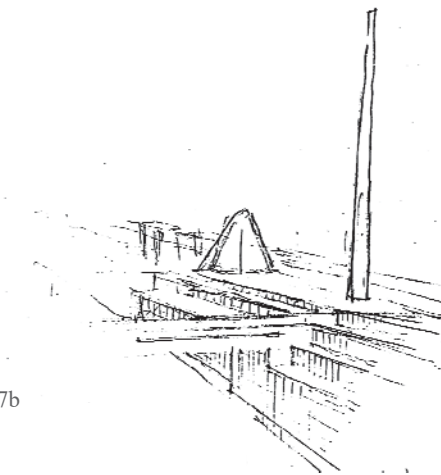

S7b

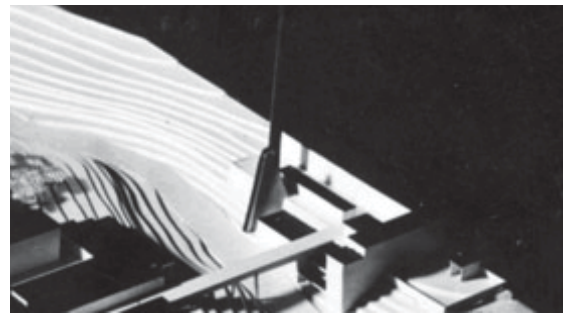

S8

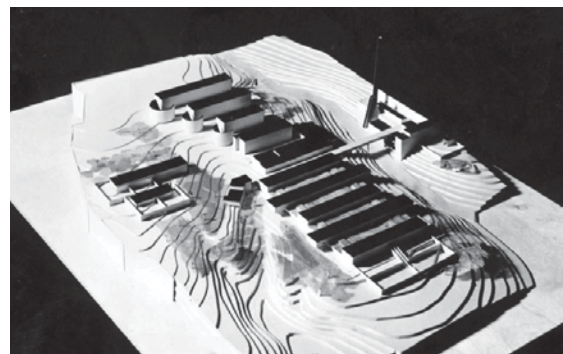

S9

FIG S6a,b,c,d – Early sketches of the Service zone IV of the HCZ competition, Aalto, source: AAA

FIG S7a – Segment of the final drawing for the service part of the hospital complex with the heat plant, power station, kitchen, washing center, common spaces and staff rooms, transport elevator from the street. , source: Aalto takes advantage of the sloped hillside of the terrain for the best organization of the all spaces. source: AAA
FIG S7b - .Early sketch of the hospital complex Zagreb, Aalto, Service part of the complex, 1930/31, source: AAA

FIG S8,9 - Original model of the hospital complex Zagreb, Aalto, 1930/31, source: AAA

FIG S10 - Mortuary Temple of Queen Hatshepsut, Senmut, architect-engineer and Queens' chancellor 18th Dynasty, c. 1490-1460 BCE Egypt (source.: www.johndnugent.com, visited 10.08.2015.)



S10

Aalto developed also service complex as an "aesthetic" part of the whole composition (monumental character) (Fig 6-9) with the evident influence of the Russian Constructivism and the Industrial Revolution. If the composition on the other hillside of the main road of the Zone 3: Center of Radiology and Physiotherapy, can compare with the structure of "Ziggurat", stepped Mesopotamia pyramid, then this Service complex composition: Zone 4, on the other side of the road, can compare with the stepped composition as the temple Hatshepsut of Egypt (Fig 10a,b). We can observe an organic and monumental architecture as the natural part of the hillside and his form as the reflex image of the other stepped composition form of the hospital building of the Radiology, Radiography, and Physiotherapy, which connect one bridge (which can compare with the ramp – main entrance to the temple). Another reason to link with the Hatshepsut Temple is that Aalto planned the Chapel next to the residential part of the nurses and service part of the complex with the sacred, monumental aspect, integrated with the nature "earth"- hillside with the ritualistic way to the chapel placed on the highest level of the sloped hillside.

Norberg-Shulz developed in his theory dialectic relation between the place and the architecture (*sense of place*). Connecting the thoughts of Martin Heidegger, where the temple stands on the ground (ground that he called "earth") and towers stands into the air, where Heidegger's earth is a "shelter agent". In this zone, we observe both, a tower that stands "into the air" and the service part, as the temple, "stands on the ground". Following the Heidegger's thoughts about the relation ground-earth, the temple built on the ground becomes an "earth" and gives the "definition" of the "ground". He said: "...earth occurs essentially as the sheltering agent"... "temple-work, standing there, opens up a world and at the same time sets this world back again on earth, which itself only thus emerges as native ground"⁵

⁵ Heidegger, "The Origin of the work of Art", in eds. Albert Hofstadter and R.Kuhns, "Philosophies of Art and Beauty", NY: Modern Library, 1964, p.671

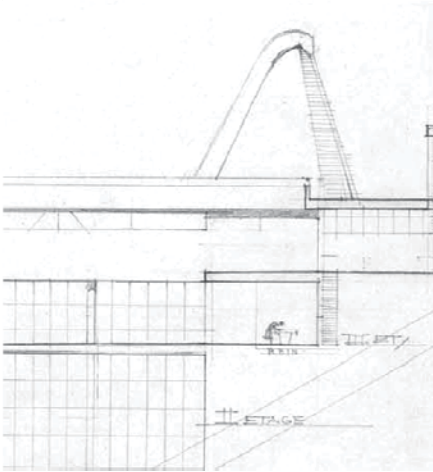

S11

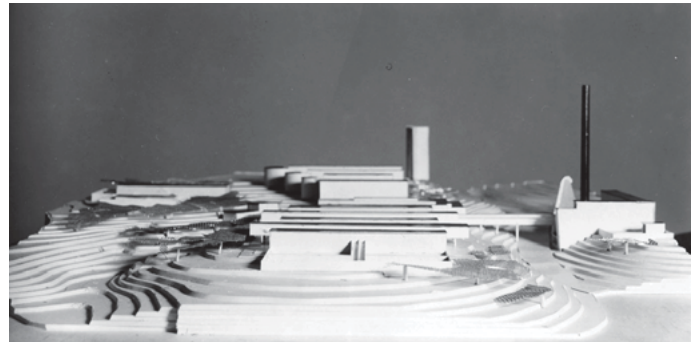

S13

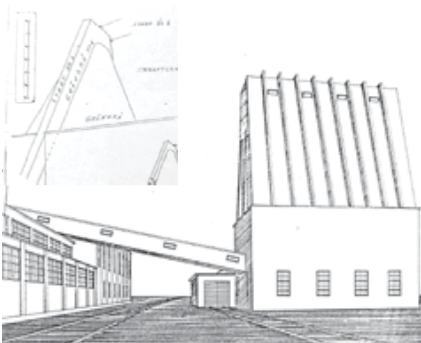

S12



S14

FIG S11 -. Parabolic -Silo of the service zone of the hospital complex Zagreb, Aalto, 1930/31 (bridge and "parabolic" silo), segment, source: AAA

FIG S12a - Sketch of Silo, Toppila-Vaara, Aalto (1930-33), source: AAA

FIG S13 - Original model of the hospital complex Zagreb, Aalto, 1930/31, source. AAA

FIG S14 - Toppila Varra pulp mill ,Aalto, 1930-33, Schildt, 1994

FIG S15 - Sunila industrial complex, Aalto, 1937 (similar stepped composition in the vertical plane)

FIG S16a,b – Sketches of the transformation of the part of the Silo from the rectangular to curved form, at the same time with the competition of the hospital complex in Zagreb, 1930, 70/8, 70/9, 70/10, 70/787b

FIG 16c - Toppila Varra pulp mill, Aalto, 1930-33 , (Detail of the composition of the Silo, Photo by the Moholy Nadgy (visited Aalto in 1931)

S15



Aalto at the same time with this competition entry developed the project of the Toppila-Vaara pulp mill Industrial complex (1930-1933) (Fig S12, S14).⁶ From the Utopians, Russian Constructivism and with the Suprematism in the Art the main inspiration is the Industrial Revolution. Their main elements and everything are connected with this technique and mechanical progress. These technical components connect with the contemporary art and ideas that Aalto later developed together with Fernand Léger. Very similar composition, he realized seven years later on the Sunila industrial complex where we can recognize the dominated principle of the stepped vertical plane of the main building, placed on the flat ground which Aalto developed as the associations "cascades" of the hillsides of this competition of Zagreb.

Aalto in this kind of the industrial buildings also experimented with his architectural ideas and new forms with plastic dimension as the monumental compositions that applied to many projects with different functions. On this Service part of the Zagreb hospital complex project, which he developed at the same time of Toppila industrial complex, we can recognize analogous composition elements, dominant verticals, the towers of the "X" rays and silo and heat plant ("stands in the air" from the Heidegger's theory). If we compare two silos, of these two projects, developed at the same time, we can find some new forms of both complexes. It is observed that he developed a simpler rectangular form of the Silo on the Toppila Vaara pulp mill and on the Service part of the complex where he created a parabolic curve form of the silo (Fig S11,12,16a-d).

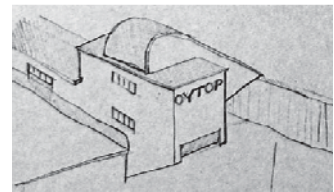
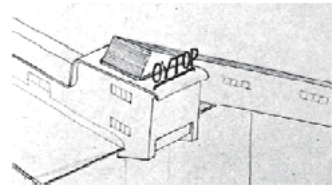

S16 a,b,c

⁶ This Aalto's industrial complex would be the inspiration for the famous photo of Moholy Nadgy in 1931. (Fig S16)

Kenneth Frampton has encouraged architects to "cultivate the site": *The bulldozing of an irregular topography into a flat site is clearly a technocratic gesture which aspires to a condition of absolute placelessness, whereas the terracing of the same site to receive the stepped form of a building is an engagement in the act of "cultivating" the site. . . .*⁷

PRINCIPLE 7

Stepped in the Vertical plane correlated with the ground

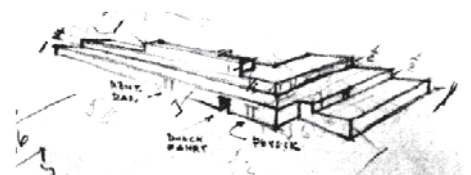

⁷ Kenneth Frampton, "Toward a Critical Regional Regionalism," in Hal Foster, ed., *The Anti-Aesthetic* (Port Townsend, Washington: Bay press, 1983). Reprinted in Miwon K won, "One place after another: Notes on Site Specificity," p. 106-107.

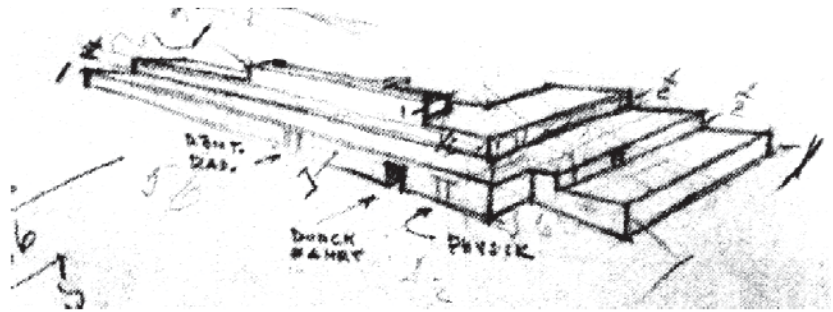

S17

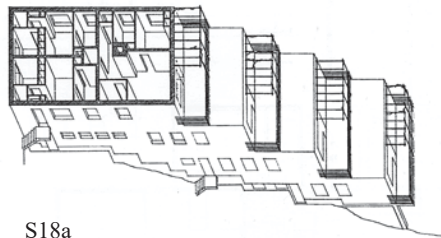

S18a



S18b

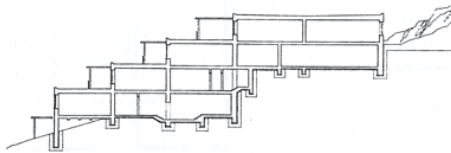

S19a



FIG S17 - Axonometric drawing of the Radiology and Physiotherapy center of the hospital complex Zagreb, Aalto, 1930/31, source: AAA (composition analogous to "Ziggurat" where is marked separated entrances by the tunnel main paths of the complex)

FIG S18a - Terraced Housing for A. Ahlström Co., Kauttua, Aalto (1937) (axonometric drawing, stepped section and side stepped façades) , source: K.Fleig **FIG 18b** - Terraced Housing for A. Ahlström Co., Kauttua, Aalto (1937), source: S.Gideon, 1968:627

FIG S19a- Museum Shiraz, Aalto, 1969, unrealized project, axonometric drawing, façade, source: AAA

FIG 19b - . Floor plan of the Museum Shiraz, Aalto, 1969, source: AAA

FIG S19c - Museum Shiraz, Aalto, 1969, unrealized project,, section, axonometric drawing, façades source: Fleig, 1995



S19b



S19c



Section A-A



EAST ELEVATION



SOUTH ELEVATION

Principle 7.a: "Tectonic" solution of the composition and form

Adapting into the terrain and transferring vertical loads to the earth, Aalto project show us the comprehension of the place and naturally configuration integrated the architecture as the one part of the ground and it is the culmination of his examination of the *genius loci* which we can analyze through the concept from Shulz's *Phenomenology*, Heidegger's theory of the ground - *earth* or Steven Holl's theories and *zero point*. Here, *genius loci* are described representing the sense that people have of the place, understood as the sum of all physical as well as symbolic values in nature and the human environment.

Shulz said: "...the word *stand* denotes the relationship to the earth. Rise the relationship to the sky. Standing is embodied through treatment of the base and the wall. Some buildings are "...ground-hugging", others rise freely, and in others again we find a meaningful equilibrium"... "Flat or sloping roofs, gables, domes and pointed spires express different relations to earth and sky"⁸

Aalto presented in many of his later projects the continuity of the experiences gained at the project of Zagreb, his permanent inspiration from the hillsides from his journeys to Italy. For the first time he created this completely "topographic stepped composition" as a part of the hillside alike the Temple Hatshepsut of Ancient Egypt. Aalto was interested in the symbolic meaning of the cultural landscape by following the topography of the earth's surface. A clear example of this stepped topographic architecture are terraced houses of the residential complex of Kauttua (1937), Housing for A. Ahlström Co. (Fig 18 a-b), carried out seven years later. Kauttua terraced houses followed the terrain configuration with the large terraces where in the both projects we can find many common features, even the similar topography of the ground, landscape integration and orientations. The stepped composition in both directions (base and section) followed the ground – "earth" on the sloping hillsides we can find on the project of the Museum Shiraz (1969), another unrealized project. (Fig 19a-d) , with the composition of the parallel pavilions analogous to the stepped vertical plane of the parallel clinics of the General Hospital of the HCZ competition entry following the hillside configuration. (Fig S20)

⁸ Schulz Norberg, "Genius Loci: Towards a Phenomenology of Architecture", Rizzoli, New York, 1980, p 66-67

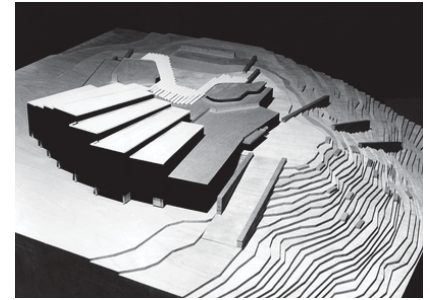

S19d

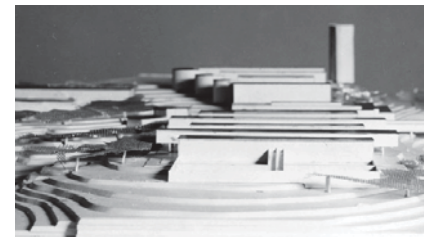

S20

FIG S19d - Model of the Museum Shiraz, Aalto, 1969, unrealized project, source: Fleig,1995 (AAA)

FIG S20 - . Segment of the model of the hospital complex Zagreb, Aalto, 1930/31, source: 50/492 AAA (parallel pavilions following the hillside – stepped composition of the whole complex viewed from the city)

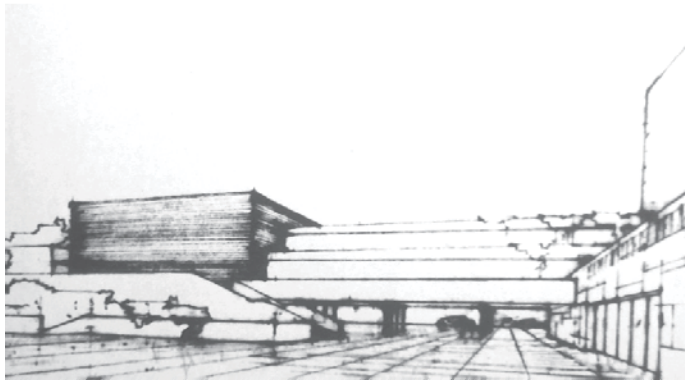

S21a

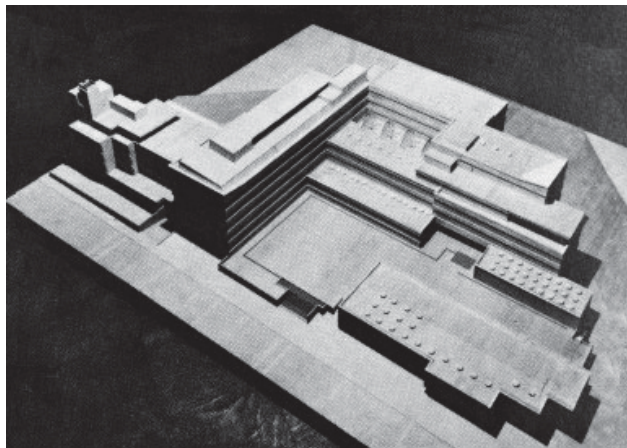

S21b



S22

FIG S20 - . Segment of the model of the hospital complex Zagreb, Aalto, 1930/31, source: AAA (parallel pavilions following the hillside – stepped composition of the whole complex viewed from the city)

FIG S21a - "Forum Redivivum", the first competition project, realized by Alvar and Aino Aalto (one of the last projects realized together), This project contains many principles from this Aalto's competition entry (stepped vertical and horizontal plane (PR8) in both directions), for Zagreb hospital complex

FIG S21b - Model of the National Institute of Pensions, 1948-52, Aalto, source: AAA

FIGS22 -Museum of Aalto, Jyvaskyla, Aalto, 1971) source: K.Fleig 1995,AAA

FIG S23a,b,c- Museum of Aalborg (1958), Denmark, Aalto, (photo, floor plan,section,perspective drawing) (double stepped in both directions horizontal and vertical),source: AAA



S23a

On the project of Aalto's Museum in Jyväskylä (1971) we can find this staggered, double stepped form in the floor plan and the section (as the stepped composition of the National Pensions Institute, Museum of Aalborg and Shiraz Museum) (Fig S20 a,b). With the very similar daylight effect of the upper windows of the "cascades" as the stepped composition with the upper windows, the first time applied in this specific way at the Radiology Center of the Aalto's competition entry for the hospital complex of Zagreb. This "cascade" window system he applied in Museum of Aalborg, after almost thirty years.

Principle 7.b –The freestanding stepped composition without the sloped ground natural base

On the many projects carried out by Alvar Aalto, after this competition project, especially in the late phase of his work (50's - 70's) we can observe that Aalto developed in many projects this stepped composition at the same time of the section and the floor plan with façade which appear also in the case of Aalborg Museum or National Pensions Institute in Helsinki (1948-52) (Fig S21) or Museum Shiraz (Fig 19b,c).

Aino and Alvar Aalto won the first prize for their entry '*Forum redivivum*'⁹ of the National Pensions Institute of Helsinki (1948), by developing the dominated monumental stepped composition of the building in both plans. After Aino's death, Alvar Aalto developed the second version of this project in 1952 using the main ideas from the first competition '*Forum redivivum*'. This project has the "sculptural" and monumental character reached by the use of the elementary forms with stepped compositions in both directions (in the horizontal and vertical plane, in the floor plan and section), noticeably similar to the composition of Museum of Aalborg (1958) (FigS23a,b,c). In this project of the Museum of Aalborg, he created, assumingly from the interactive associative memory, stepped composition as an image building balancing with the image of the shape of the hill behind the building, sloped in the other direction of the composition.

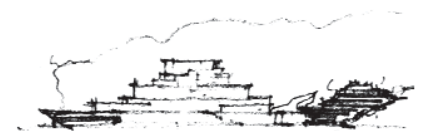
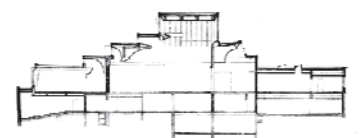
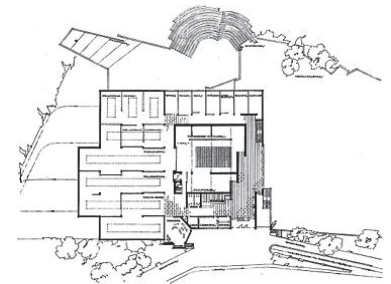

S23b,c

⁹ One observation: This project is the last project which Alvar carried out with his first wife Aino, with the first competition entry of the University of Technology of the Otaniemi campus. Both project are as one type of synthesis of some ideas from this Competition for hospital complex of Zagreb.



S24

FIG S24 . Stepped artificial configuration of the ground of the Saynatsalo Aalto, 1949, source: Schildt, 1984:205

FIG S25 - Stepped configuration artificial of the ground of the "Auditorium of the main building of the University A.Aalto in Otaniemi , 1949 first competition, and developed the project of the main building 1955-65 and others until 1974 . He created elevate base as the platform of the Auditorium and on this way he developed one open space with dominate monumentality as the "Sacred Temple" and re-interpretation of the Ancient Agora or Acropolis with the Classic form of the Amphitheatre, as Odeon on the Acropolis.



S25

In this composition, we observed one difference on the ground (Fig S23), the flat base of the composition. This form is born on the sloped hillside as in the case of the Radiology and Physiotherapy Center and the Service part of the Zagreb Hospital. By analyzing the Alborg Museum facade, we can see that glass stepped façade is very similar to the façade of the early sketch of the service part of Zagreb hospital complex with a very similar windows system of the whole façade front and with stepped both plans: horizontal (floor) and vertical (section, façade).

Principle 7.c–Tectonic manipulation: steep terraced slopes of the ground

This principle of the ancient city with the terraced hillsides stepped in the vertical plane like stairs; we can comprehend the one of the main “obsessions”¹⁰ in the trajectory of Aalto. He often artificially configured the flat terrain by reconfiguring the terrain with the terraces to elevate the main compositional buildings to the highest level of the composition – as the platform (with sacred and monumental character), like one re-interpretation of the Ancient city and “Acropolis”. Aalto in his description of the site of this competition entry called this Salata hill “Acropolis”¹¹ with the sloped terraced hillsides, planned the new “hospital city” as the monumental Parthenon of Athens (as Heidegger’s Temple on the Ground-Earth). He described the terraced hillside of the Zagreb competition site as the inspiration and the perfect place for the hospital function. He always had on mind “one travel” to Italy where he found inspirations from the small medieval city on the hill with the sloped terraced hillside. This principle of the stepped artificial terraced configuration of the ground we can find especially in his works of the second half of the 40’s and 50’s as the Saynatsälo’s elevated platform base of the central building and in the stepped ground (1949) (Fig S24). Also, the similar method he used to elevate the stepped base of the Lecture Hall of the main University building in Otaniemi (1949-1955) (Fig S25).

¹⁰ Shildt G., *Aalto in his own words*, New York: Rizzoli, 1997

¹¹ Arkkitehti XII, 1932, p.5

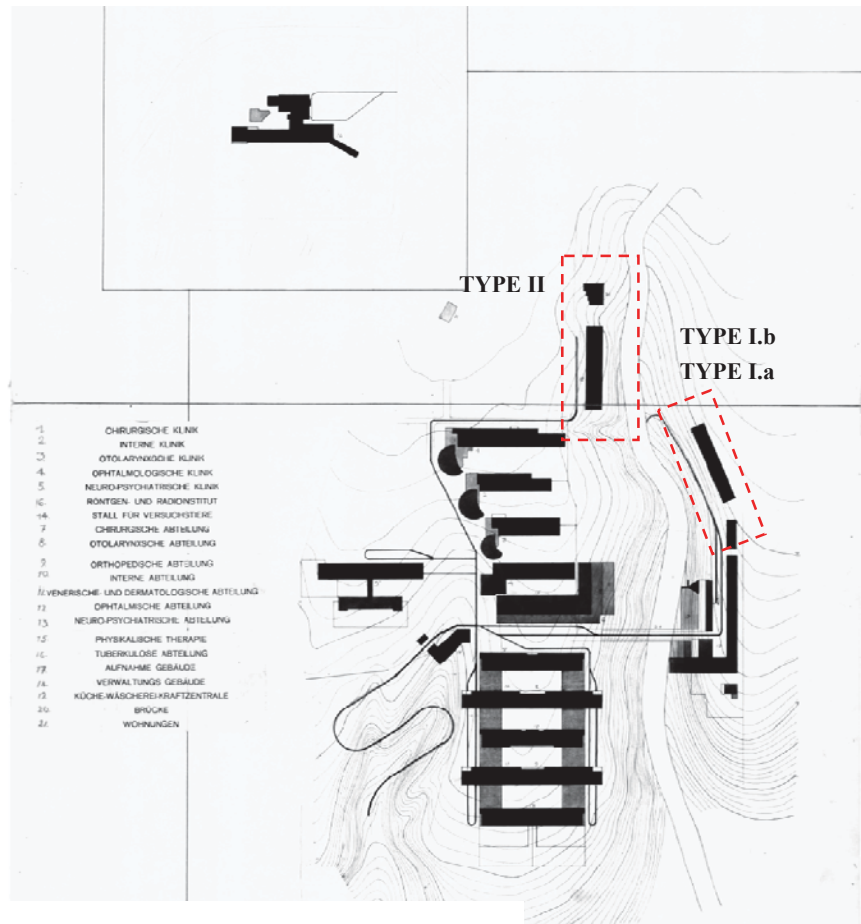
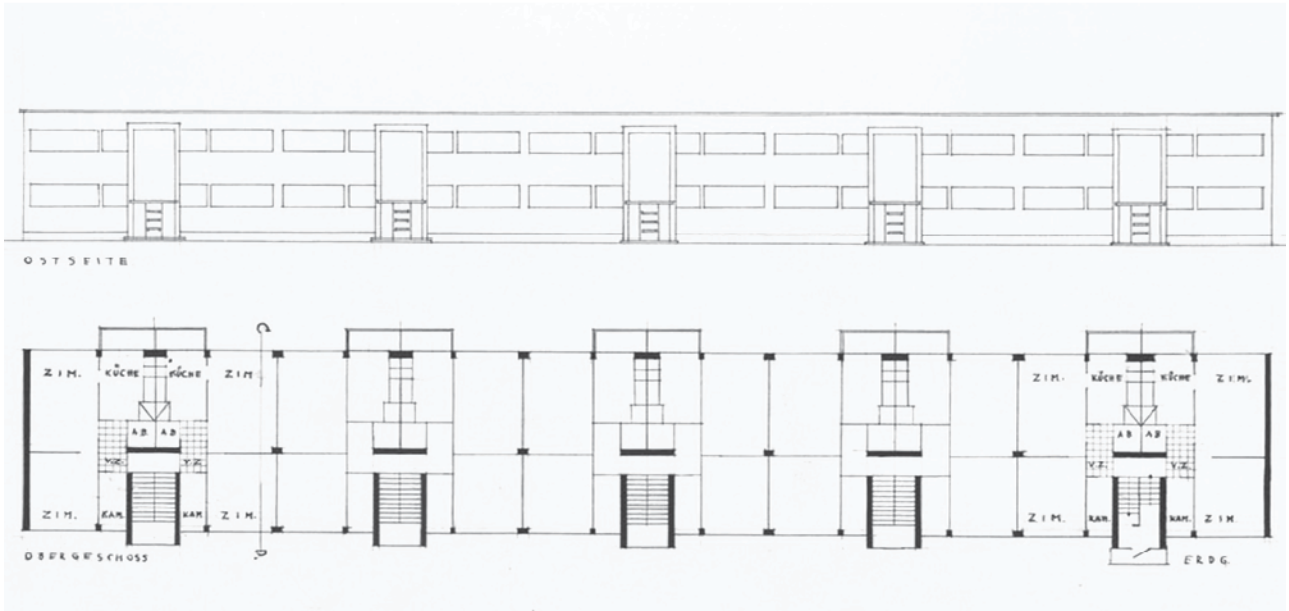

FIG. V.1a – Urban composition plan, Aalto, AAA (50/610). Marked three residential areas

ZONE 5

Residential and Administrative area



V1b

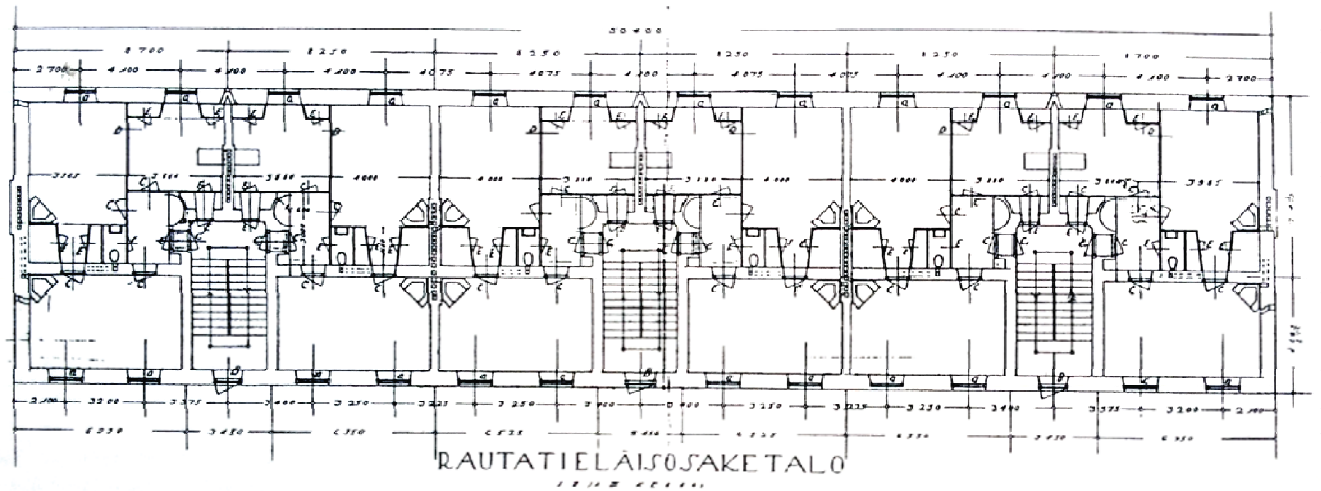

V2

Comparison:

FIG V1b -Apartments for the hospital complex staff, type Ia, competition entry of hospital complex of Zagreb, 1930, Aalto, source: AAA

FIG V2 – Apartments of Railway official's block of flats ("Ira Building") in Jyväskylä, 1924-26, source: AAA

In 1930, Aalto commenced establishing the functional ideas of the modern residential buildings and minimum apartments in Helsinki, where also in 1930, with Aino Aalto organized an exhibition devoted to minimalist apartments with new modern furniture and functional kitchen applying the new ideas, as an answer to CIAM III of Brussels, held at the same time with the competition entry in 1930, where he came across the same themes dealing with the new residential architecture. These ideas, which Aalto established within HCZ of the residential areas, will be developed also in the residential complex of the sanatorium in Paimio, designed around the same time as the row social buildings. They were similar to the town-houses of the Ernest May, one of the members of Modern Movement "Hard Line"¹, who carried out few residential complexes of the social living in the Frankfurt surroundings, which Aalto visited in 1928. (Fig V3,4)

Aalto developed two types of residential buildings for the medical staff in the north part of the HCZ: **type Ia** (Fig V1 a,b), which he used in the same year in the project of the residential part of the hospital complex in Paimio. He also developed for the same group of the residential buildings, **type Ib** - mixed use low row buildings with administrative spaces and the residential part for the hospital staff, and the tall characteristic stepped residential tower, **type II**.

In this study the analysis is focused on the specific Aalto's language included in **type II** of the **ten-story stepped residential tower**, representing a new type of the residential buildings that he designed for this competition entry. This residential building type can also be seen as an important new principle of the Aalto's architectural language. Here, for the first time, he uses in a very authentic way, the stepped form of the residential building base and the main façade, which is the new principle that he will use in almost all of his residential projects, and at the same time, this is one of the main principles of his architectural language applied as the main or annexed stepped form in the horizontal plane (ground floor plan) (8. Principle).

¹ Here we observe strong influence of the Russian constructivism and the "Hard Line" of the Modern Movement.



V3



V4



V5

FIG V3 – Residential complex of Siedlung Bruchfeldstraße (1926-1927), Frankfurt, Ernest May, source: *kunst.uni-frankfurt.de*

FIG V4–Siedlung Praunheim Reihenhäuser, Frankfurt 1926, Ernest Ma, source: *baugeschichte*

FIG V5 - residential part of industrial complex of Sunila, 1937, Aalto, AAA

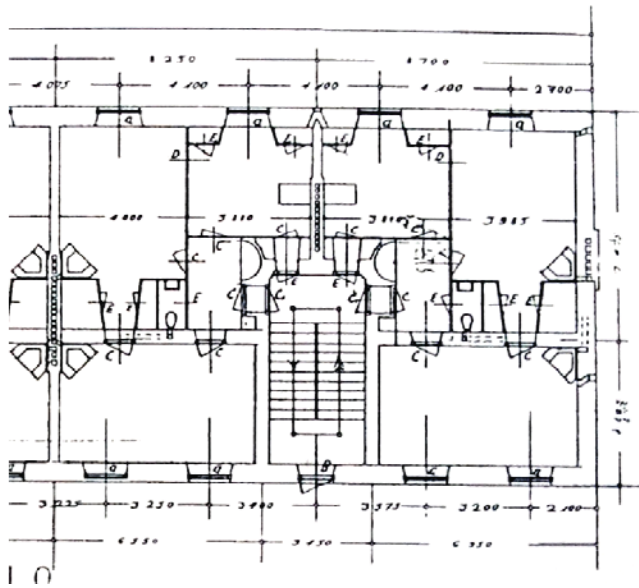

V6

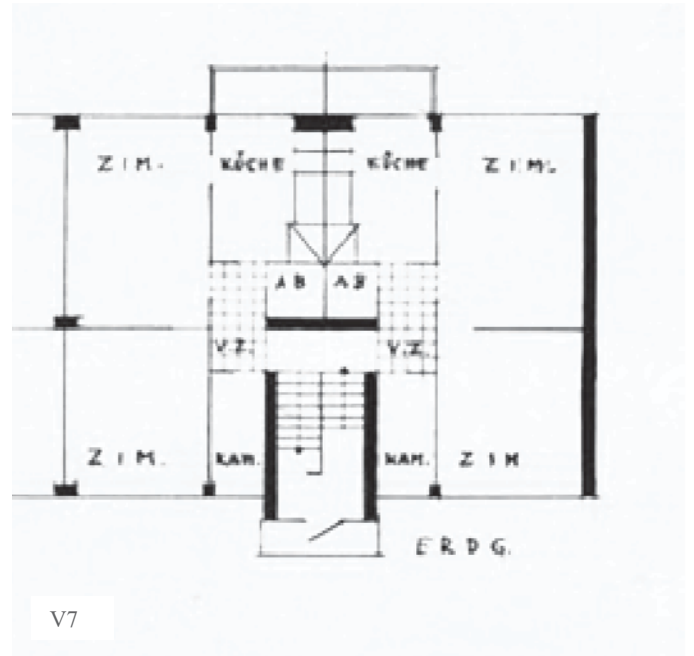

V7

FIG V6 – Apartment of Railway official's block of flats ("Ira Building") in Jyväskylä, 1924-26 , segment source: AAA

FIG V7 –Apartments for the hospital complex staff, competition entry of hospital complex of Zagreb, 1930-31, Aalto, segment source: AAA

FIG V8 - Residential complex of theSanatorium in Paimio, 1930-33, Aalto, *Aalto worked at the same time on the residential buildings of Zagreb and Paimio (1930-33)

V8



Moreover, after these two projects of Zagreb and Paimio hospital complex he used this type for the residential part of the industrial complex, as in Sunila industrial complex (1937), (Fig V5).

I Type of Building – as “Ira Building”

The first type of residential buildings respected all the rules of the international style as we could observe previously in the Le Corbusier’s buildings, Bauhaus and master houses of Walter Gropius and Weissnehof in Stuttgart (1927). One year before this competition project, Aalto participated in 1929 in the second CIAM where he visited buildings realized by Ernest May of the Frankfurt surroundings which influenced concept of residential buildings (type I), Residential complex Siedlung Bruchfeldstraße (1926-1927) and Siedlung Praunheim, Reihenhäuser (1926), Frankfurt (Fig V3,4) This first type of residential buildings, which Aalto applied here in this competition entry, is similar to the residential buildings of physicians carried out at the same time with Zagreb competition entry (1930/31), for the residential part of the Extension of the hospital complex in Paimio (Fig V7, V8).

Aalto designed in autumn 1924 and finished in 1926 project of Railway official’s block of flats (“Ira Building”) in Jyväskylä (Fig V2,6). The three-story brick building contains eighteen identical flats, comprising of two rooms, a kitchen, bathroom and hall, grouped around the three stairways accessible from the courtyard, which were conceived as the gardens. This Railway official’s block of flats was Aalto’s first social solution of the problem for providing housing for the lower middle class. By analyzing typical flats of both projects, Jyväskylä residential block (1924-1926) and the flats of the residential building type I of the Zagreb hospital complex (1930-31) (Fig1b, 2), it is observed that they have a similar organization of the spaces with two rooms, kitchen, bathroom, and the hall. *The sober façade, prefigures Aalto’s Rationalist apartment blocks from the 1930’s*² used here for the competition entry of Zagreb (Fig V1a,b) and at the same time (1930) for the residential complex of the Sanatorium in Paimio. Afterwards this form is used in the residential blocks of the industrial complex.

² Schildt G., 1994, p 207

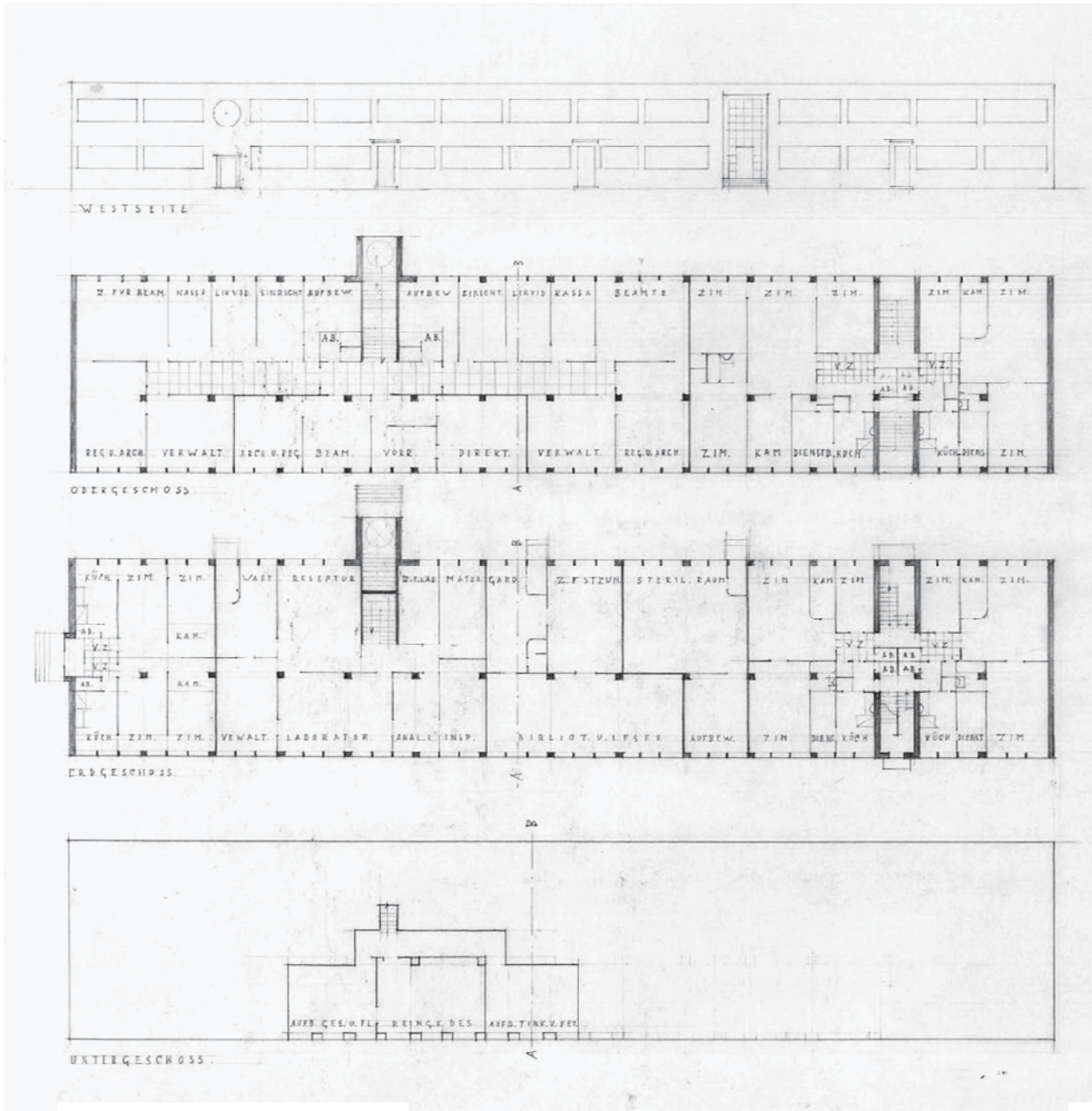

FIG V9 – Type I.b of the Mixed use building. (Ground floor, first floor, façade) Administrative part and Residential part for the hospital complex staff, competition entry of hospital complex of Zagreb, 1930-31, Aalto, segment of 50/627, source: AAA

V9

Residential buildings: **Type Ia** Aalto located on the other side of the road (Fig V1), because the program required separation between the residential building of doctors and the other staff of the complex, and also required apartments for the staff which contain two rooms, kitchen, bathroom, and the hall (very similar to the organization of his realized residential block "Ira" (1924). Because that Aalto has the first association from that previously realized apartments, which will influence also on the residential complex of the Sanatorium in Paimio and other his residential buildings.

Type Ib – building of mixed use of the residential part of the Zagreb hospital complex (Fig V9) (administrative and residential). In the north part of the complex, Aalto planned a two-story row building (Similar composition of the Type I.a).

At the ground floor, in the right and left side, Aalto planned the residential units with their independent entrances on the ground floor. Right residential part has two levels with the stairs at the both sides. Left side of the building has just a residential part at the ground floor. In the other part of the building he planned the administrative spaces of the complex with library and laboratories on the ground floor, director spaces, administrative and accounting offices, etc., all situated on the first floor.

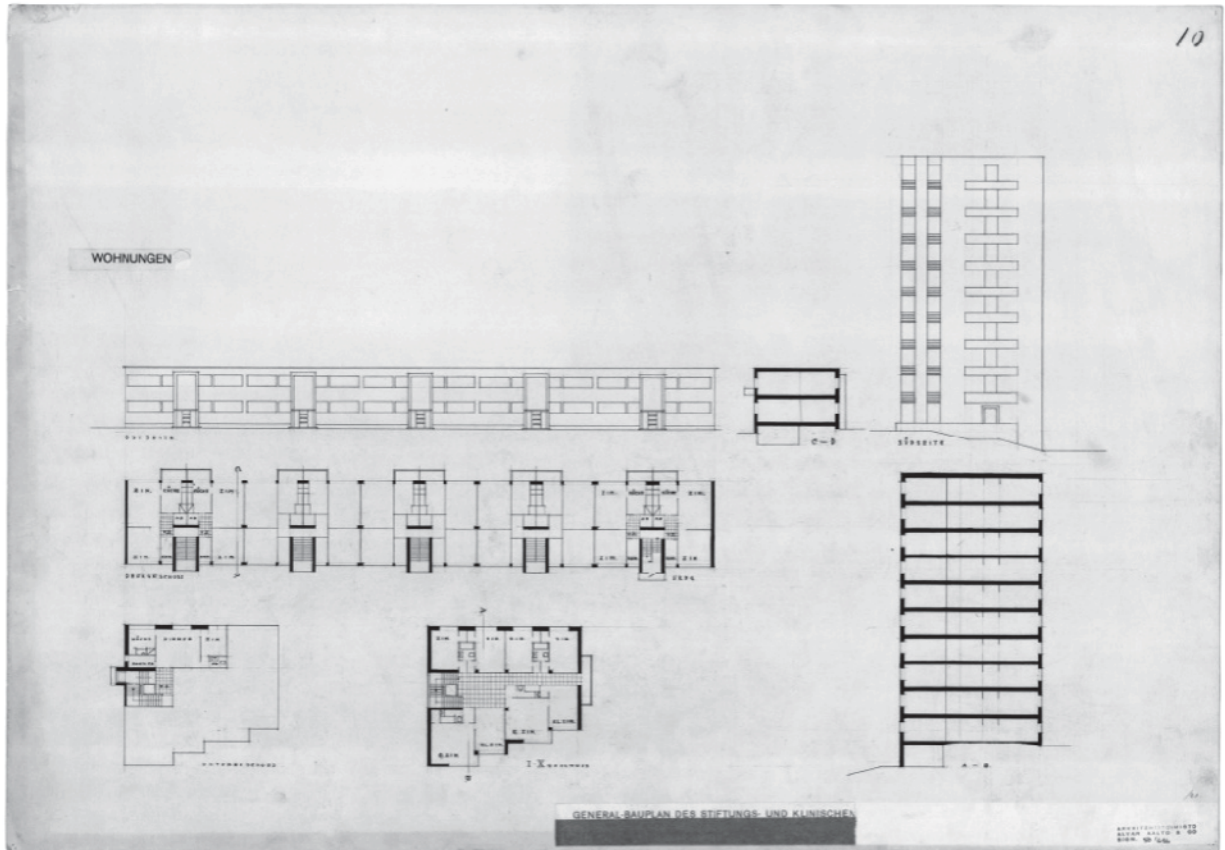

FIG V10 - Final drawing of the Apartments for the hospital complex staff, competition entry of hospital complex of Zagreb 2 types, 1930, Aalto (floor plan, section, façade), source: AAA

II type of the residential building

PRINCIPLE 8

"Stepped in the horizontal plan"

Climatic responsive Architecture/
individual – collective

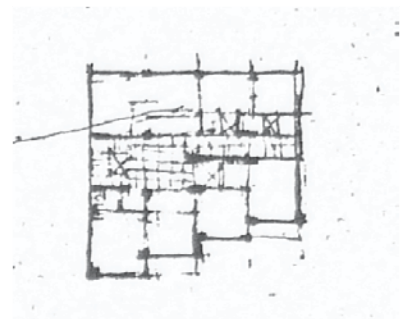

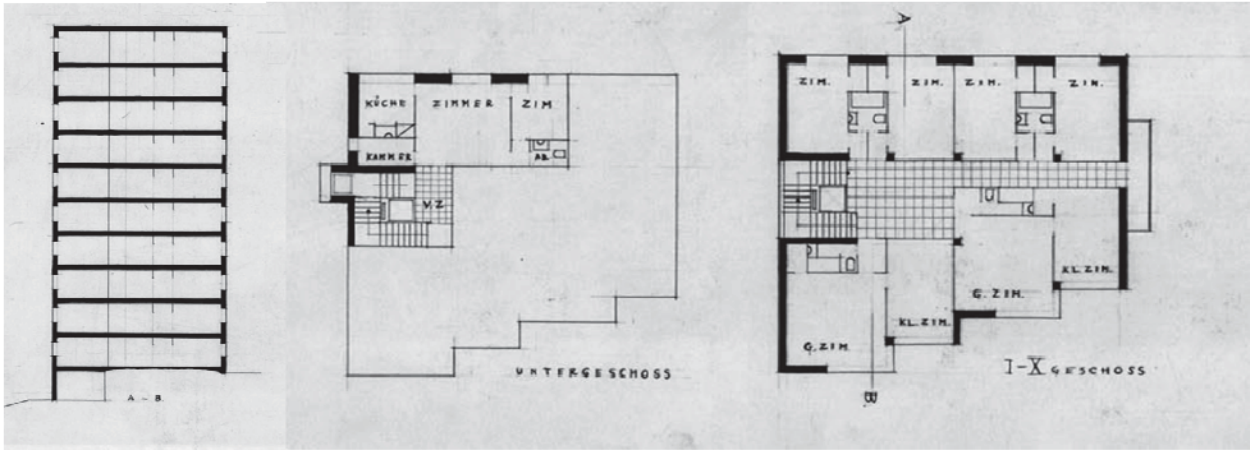

V10a,b,c

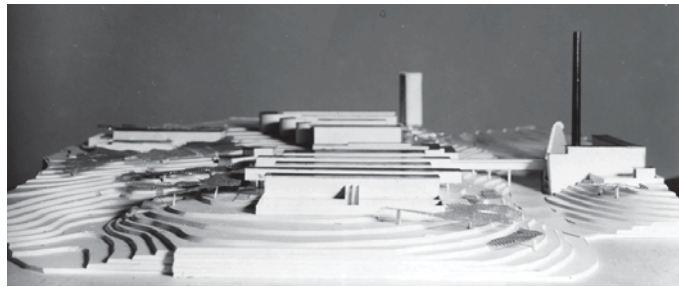

V11

FIG V10a,b,c -Final drawings of the residential buildings for the staff of the hospital complex, Type 2, stepped tower of the competition entry HCZ, 1930/31,Aalto , source: AAA (Floor plan s, section)

FIG V11- Original model of the competition entry HZC, 1930-31, Aalto, source: AAA (view from the South of the complex, from the "new" city center)

FIG V12 a ,b - Residential block stepped in the horizontal plan , Zig-Zag Ernest May, Frankfurt, 1926, (stepped forms of the floor which Aalto could be used for the comfort , privacy, and climatic conditions)



V12 a,b



2. Type of the residential building – Stepped in the horizontal plan

In the residential part of the HCZ (1930/31), Aalto developed for the first time a residential ten-story tower with the characteristic "stepped" form of the base which he will use after in numerous residential projects and as a recognizable feature that we find in a number of Aalto nonresidential objects as well. (Fig V10, 11)

This represents a leitmotif of the compositions (in the alone freestanding or annexed form). It can be learned that his goal was to create a residential tall building as a kind of the "stepped" vertical row individual house system (as the May's zig-zag low residential building of the Frankfurt's surroundings) (Fig 12a,b)

The corners of the building flats as the glass transparent panels can be move and in this way it's possible convert the interior space of the living room and the bedroom into the one open-air terrace seemingly integrated with the Nature, (Fig V10). The building had the square elementary form (with the stepped main west façade) and the central hall, which led to the community terraces for all floors, applied and viewable on the final drawings. In the same example of typical eight floors of the ten-story building Aalto designed the apartments with the salon (big room) and another small room, both exteriors with the stepped façade and daylight coming from the west and south. Next to the entrance of the apartments, he organized two bathrooms on the same level with the closet of the rooms. (Fig 13,14) In the east of the building he organized the small units with rooms and bathroom and in the extension of the bathroom, he planned a closet in the room, placed on the same level. On the last floor of the building he planned the flat for the main medical employees with their own kitchen, main room and the small room, all being oriented to the east. Aalto designed all these apartments and rooms of the building without a kitchen (because the complex had one central kitchen).

In May's social apartments blocks in Frankfurt surroundings we can find some possible inspirations of Aalto, especially in the stepped form of the social residential block with the horizontal plan "zig-zag" (1926), (Fig 12a,b). Aalto often implemented this stepped base and façade to provide the privacy for each residential unit with the comfort of individual houses within the collective spaces.

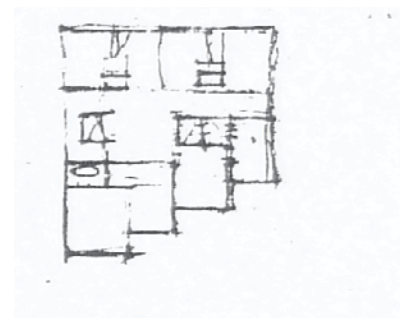
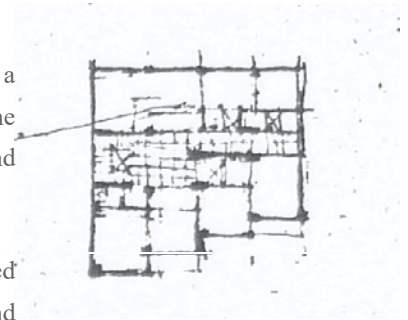

V13,14



V15



V16

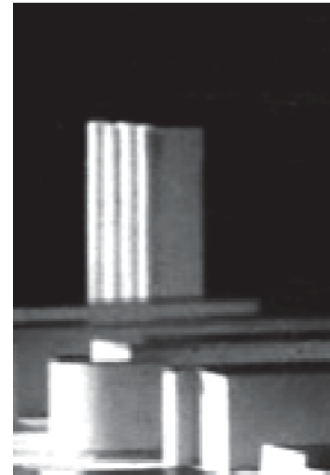

V17a

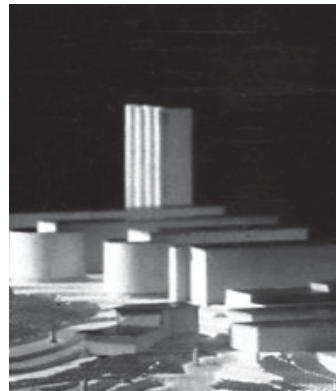

V17b

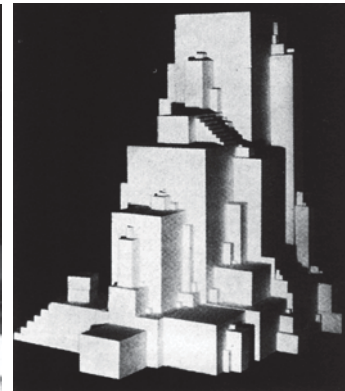

V18

FIG V13,14 - Sketch of the stepped floor plans of the residential buildings for the staff of the hospital complex, Type 2, stepped tower of the competition entry of hospital complex of Zagreb, 1930/31, Aalto, source: AAA

FIG V15 - Facade residential buildings for the staff of the hospital complex, Type 2, stepped tower of the competition entry of hospital complex of Zagreb, 1930/31, Aalto source:AAA

FIG V16 - Photo of the column of the Parthenon, photo of Aalto, 1933. Aalto's photo, source: Schildt, 1994

FIG V17a,b,c - Segment of the original model of Aalto Type 2, stepped tower of the competition entry of hospital complex of Zagreb, 1930/31, Aalto, (AAA)

FIG V18 - Model "Vertical Arkitekton" 1920's from Supremacist. Kazimir Malevich, source: <https://astrofella.wordpress.com>, visited: 12.09.2015.

V17c

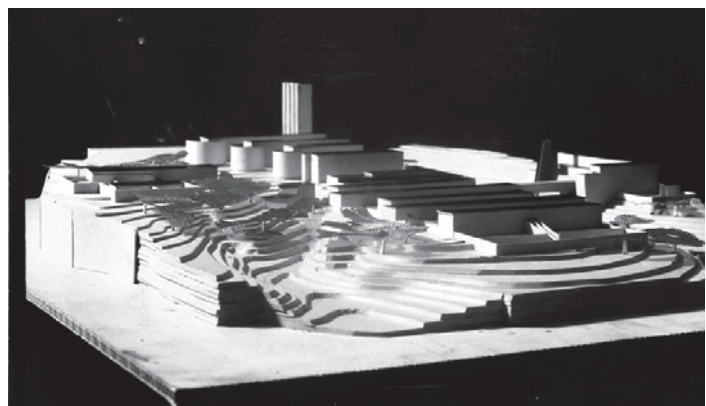

This method he uses in numerous projects with different functions: residential, educational, cultural, health buildings. Aalto called this competition site "Acropolis", and we could see that in the visit of the Athens (three years after this competition entry, on the 1933 CIAM congress held in Athens) he made some photos inspired by the forms of the Parthenon of the Acropolis. Some photos feature the details of the column (Fig V16) and we can recognize the slope of the hill and the stepped form of the main façade of HCZ residential tower (Fig V17 a,b,c) on the Aalto's early sketches (Fig V19).

The stepped shape of the main west façade Aalto used for the first time in this way, which later he reconsidered in his works especially in projects of the residential use.³ In analysis of the stepped forms new idea we can find the origin in the ancient structures and from the one composition stepped in the vertical and horizontal plan as "Vertical Arkitecton" of 1920's from Suprematist Malevich's art (Fig V18) which Aalto analyzed and used as an inspiration for his work, as he spoke that the art is the "crystallization" of the architectural idea.,it is apparent in the project which he developed at the same time with HCZ, Tehtaanpusito church, in 1930, (the first competition entry, 1930 second in 1932), where we could, also find the similar Suprematist form of the Mallevich's "Vertical Arkitecton".

The stepped residential tower from HCZ competition entry, was created with the premeditation to preserve all qualities and comfort of the individual houses as in the May's white residential buildings with flat roof in the "zig-zag" residential blocks This considered the simple form with large green areas and gardens inside the block which provided the privacy and the peace with all comfort and functionality of living in individual houses. The stepped facade will convert to his main motif in multi-family residential projects during all his trajectory. (Fig V19)

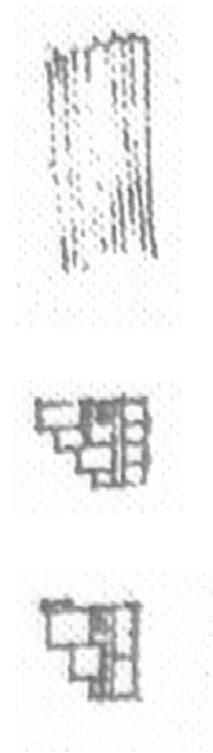

V19

FIG V19 – Sketch of the stepped façade and floor plans of the competition entry of Zagreb, 1930/31 Aalto, source: AAA

³ Schildt G, "Alvar Aalto: The Decisive Years", Rizzoli, New York, 1986, p248. This information also confirmed the biography of the Aalto G.Schildt in his brief description of the competition entry where he wrote that this residential building foreshadow future residential buildings of the work of Aalto. Also that confirmed after Radovic D. (1995, 1997) and Harausky A. (*Covjek i Prostor, 1997*) and Laslo A. (*Oris,2004*) in their short articles about this Aalto's competition entry.

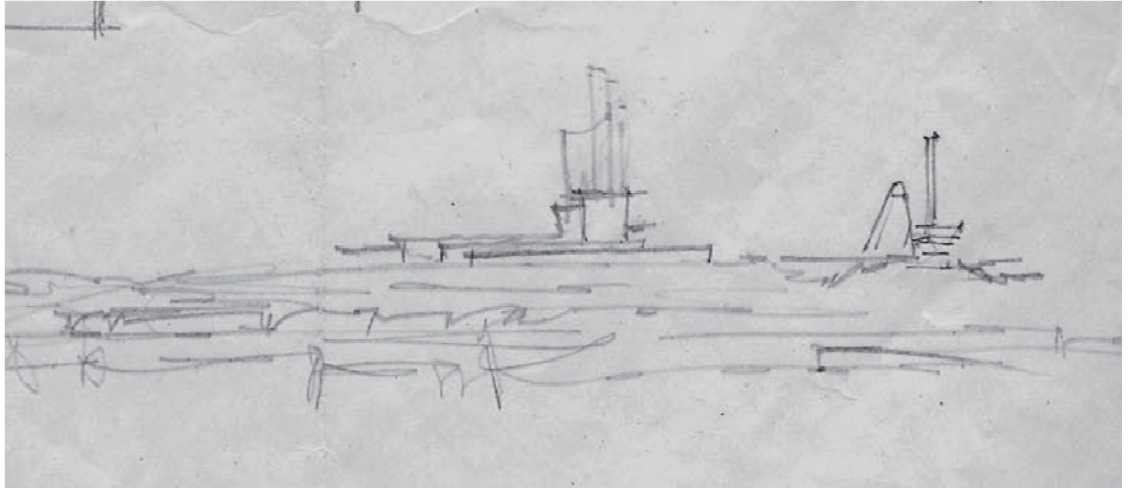

V20



V21

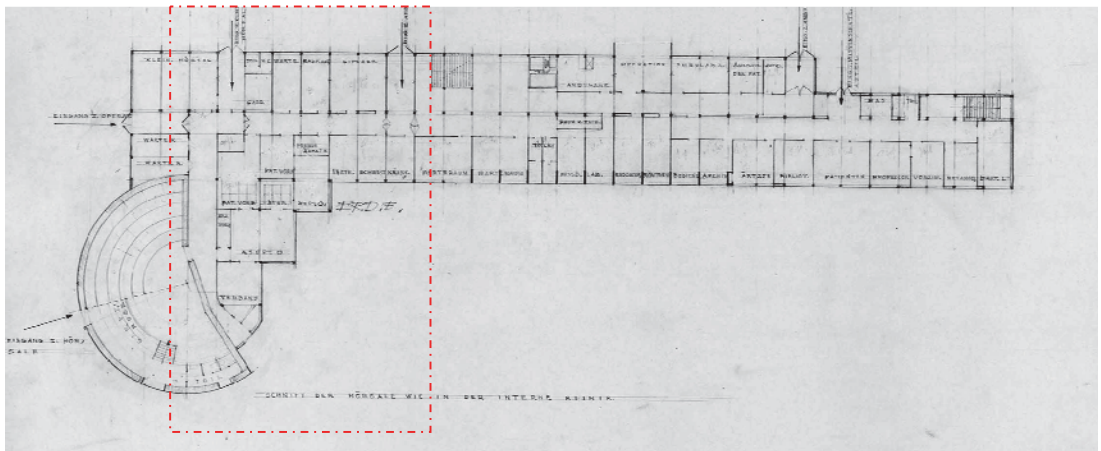

V22

Aalto has developed this stepped form of the façade and the base to answer protection issues due to the climatic conditions and strong winds on the hill. At the same time Aalto wanted to give the privacy of each apartment and also to provide the best orientation for the best insolation and ventilation of the residential spaces. Also, this form was influenced by the possibility of visual access of the hospital complex from the flats of the medical employees (and the view on the city center at the same time). Aalto's stepped façade by glass mobile panels converted easily from the interior to the exterior space, as some kind of symbiosis with the natural environment of the forest at the hill.

It is observed that on some early sketches Aalto experimented with the different height of the Residential building in a notion of the Acropolis image from the city and by this he established a dialogue and the visual connection between the two towers of the gothic cathedral, located in the old city center, with the residential and "X-rays" tower as the two highest points of the complex (Fig V20, 21).

This mechanical characteristic of a "mobile" and stepped annexed composition around the semicircular form had a different imaginative "connection" with the three clinics auditoriums. In the case of the connection of the Lecture Hall with the Surgery clinic, of the Zagreb hospital complex, this "neck" is the biggest in this Surgery ward composition - "head and body", where Aalto created stepped annex on the ground floor, where he needed to organize different operating rooms and other necessary rooms next to the Lecture Hall⁴ (Fig V22).

Simultaneously with establishing of these ideas, Aalto developed a new system of upward-slanting windows which also could have inspired the stepped frames of the part of the connection with circular hinge ("hinge" as the circular form of the lecture hall). This stepped annex of the surgery clinic with the operating rooms could influence this stepped floor plan of the residential tower, as the internal dialogue in the northern part of the complex.

FIG V20- Sketch of Aalto of the hospital complex of Zagreb (as "Acropolis"), dialectic image with the two tower of the gothic cathedral, source: AAA

FIG V21- Two panoramic photos of the Zagreb, to the site of the competition on the hill next to the center, and other of the cathedral of the center viewed from the hill, source V21: Laslo, Oris, 2004)

FIG V22 -floor plan of the Surgery Clinic which need the biggest annex space with operating rooms next to the Lecture Hall, Zagreb, Aalto, source: AAA

V23a,b



V24a,b



V25a,b

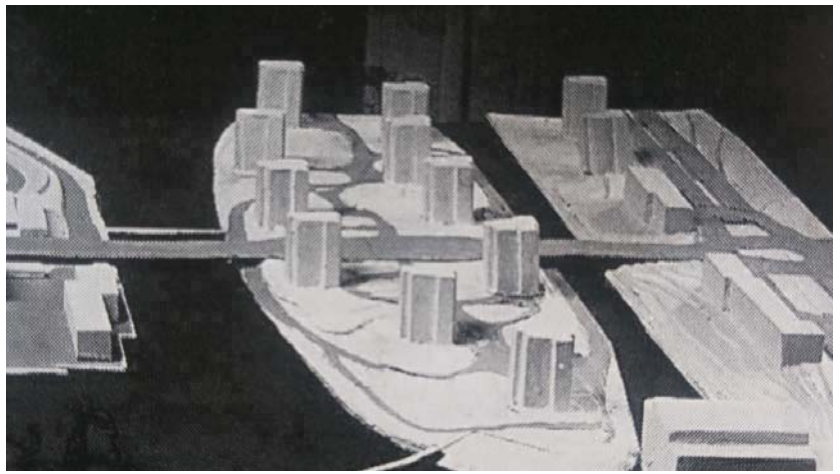

Derivations of the stepped form: Stepped floor plan of the residential buildings

The same natural environment and analogous forms he applied in his two urban residential sets with eight identical residential buildings featuring the stepped façades in Tapiola, Espoo, Helsinki (first phase carried out in 1962 with first four stepped buildings and behind this zone few years later he repeated other four buildings with the same features), completely integrated with nature (Fig V23a,b). In the composition of the "stepped" facade of the Tapiola residential building, Aalto developed the closed system of the façade, due to Finnish climate. This also aids in increased privacy of a multi-family building with big window surfaces used for the best insolation. We can relate this project to the residential building in the Hansaviertel neighbourhood in Berlin in 1955 (Fig V24a,b), where Aalto in an analogous way developed the stepped front of the rooms with the balconies.

Another example of these "stepped" residential towers, Nynashamn residential blocks of Sweden(1946-48) (Fig V25a,b), are characterized by the stepped buildings which are the result of the standardization established before the Tapiola urban plan . This principle Aalto used, also, in a number of low row house blocks as Row houses in Sunila (1937) or Row houses in Jakobstad, Pietarsaari (1963-65). Stepped form followed the topography of the ground (where is observe synthesis of the two principles of the topographic stepped architecture in the vertical plane and often also in the horizontal plane) (Fig V27, 28).

*"The thirteen-story tower block in Viitatorni, Jyväskylä (1957-61), was built with a stepped façade (analogous to this residential tower of HCZ). In this last phase Aalto formed this stepped façade in order to link it with the old houses surrounding"*⁴ (Fig V29).

FIGV23a,b – Tapiola residential blocks with the same stepped forms (as the residential tower of Zagreb) , 1962 and 1968 , Aalto. Aalto built first group of this buildings in Tapiola, Helsinki, 1962 and other 1967. source: author

FIGV24a,b– Hansaviertel residential building in Berlin in 1955, Aalto

FIGV25a,b- Model of Nynashamn Residential blocks, 1946-8 unrealized, AAA

⁴ Schildt G., 1994, p.222

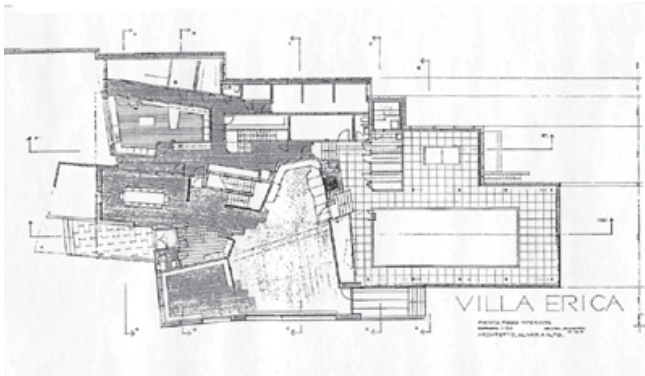

V 26a

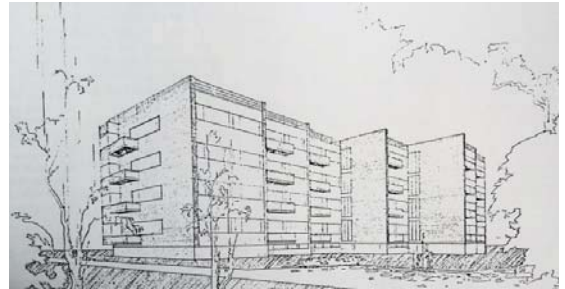

V 26b

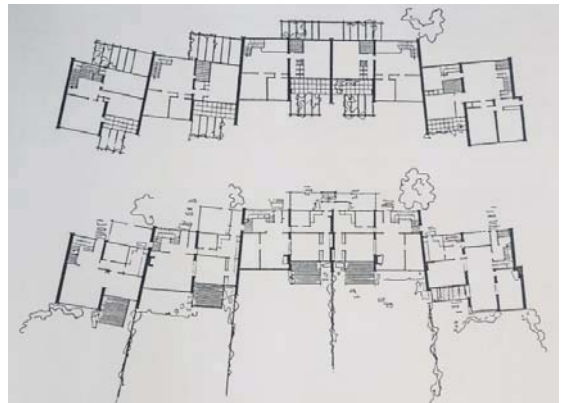

V 27

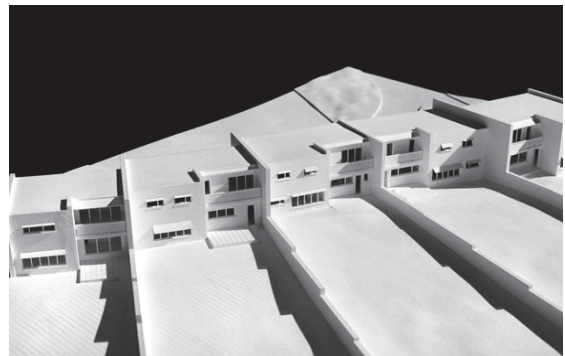

V 28

FIG V26a- Villa Erica, Italia, 1967, Aalto, source: Schildt, 1994, AAA

FIG V26b – Riviera apartment houses, Aalto , source: Schildt, 1994, AAA

FIG V27 – Floor plan, stepped horizontal plan of the residential block of Sunila, 1937, Aalto, Schildt, 1994, AAA

FIG V28 – Model, stepped horizontal plan of the residential block of Sunila, 1937, Aalto, Schildt, 1994, AAA

FIG V29 - "The Viitatorni tower" in Jyväskylä (1957-61),Aalto Schildt, 1994, AAA

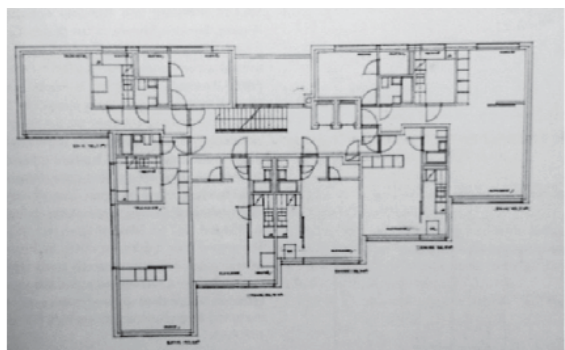

V 29

Derivations: Stepped floor planning of Aalto's non-residential projects

Stepped form in the horizontal-floor plan Aalto used in many buildings designed for various use, and not just for residential buildings. As we explained in the last part, the variations of these new principles of the stepped form in the horizontal plan, often made compositions as a "collage" with other new principles. This is noticeable in the fan shape and repetition of the segments of the composition (in the stepped order in horizontal plan) or with the other principle of the stepped composition in the vertical plan (of the section). This combinations of different principles which we observe for the first time in this HCZ competition entry we recognize in many Aalto's projects. In an acclaimed project of the buildings of the University in Otaniemi Aalto applied the stepped forms in the main entrance zone next to the main motive of the composition- Lecture Hall- Amphitheatre, where we can find analogy in this stepped form of the annex with the operations rooms of the Surgery clinics next to the Lecture hall of the School of Medicine from HCZ entry.

He frequently used number three in the composition as we find in majority of this project three stepped segments. As in this project of the residential tower of Zagreb, three segments appear in the main entrance of Otaniemi University, another building of this Otaniemi campus, three stepped elements on the façade of the ground floor and the first floor of the Ville Louis Care (France). Three stepped element of the Finland hall and three annexes of the concert hall (Fig V34), Aalborg museum and in many other projects.

This number of three main elements-segments of the composition it was previously observed in the Russian Constructivism and in the example of the Malevich's Rusakov Worker Club (1927) which also influenced the main ideas for the Finnish concert hall. This number three as the "Trinity" (*disambiguation*)⁵ connected with the Russian culture could also affect the formation of Aalto's architectural language.

We observed both these principles, stepped form in the horizontal and vertical plan, jointly applied in the Sport Hall project of Otaniemi campus (1962) (Fig V33), in the

⁵ The Christian doctrine of the **Trinity** (from Latin *trinitas* "triad", from *trinus* "threefold") defines God as three consubstantial persons, expressions, or *hypostases*:^[3] the Father, the Son (Jesus Christ), and the Holy Spirit; "*one God in three persons*".



V 30



V 31

FIG V30 -Photo of the main entrance to the building of the University of Technology of Helsinki, Stepped forms of the stairs next to the entrance of University of Otaniemi, 1962,Aalto (*Aalto used this stepped form as the annex of the different function on many projects*)

FIG V31,32– Otaniemi,part of the main building , 1962, Aalto,



V 32

Museum of Aalborg (1958) (Fig V35) and in National Pensions Institute in Helsinki (1948-1955), (Fig V36).

One of the first nonresidential project, is the Finnish Pavilion at the Paris Exhibition (1936/7) (Fig V37), which he realized a few years after HCZ competition entry and where he applied the stepped form in the horizontal plane. In this project he implemented integrated the "stepped form" principle with other principles that emerged out of HCZ project, like rectangular auditoriums with "trimmed" corners and the organic composition "in movement as "head and body". Also, on many villas projects we observed this stepped floor plans as the famous Maison L.Carre (1957-59), (Fig V39).

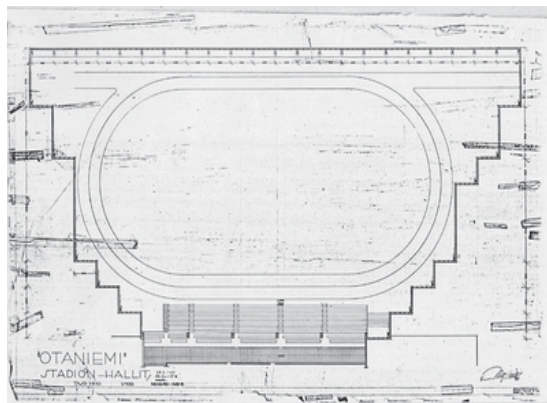

V 33a,b



V 34,35



V 36a,b

FIG 33a,b- Sport building. Otaniemi ,stepped form. , 1962, Aalto

FIG 34 - Finland hall, 1962, Aalto, source: Schildt,1994 and AAA

FIG 35 - Museum Aalborg, 1958, AAA

FIG 36a,b - National Pensions Institute of Helsinki, 1949-1955, Aalto
Source: author

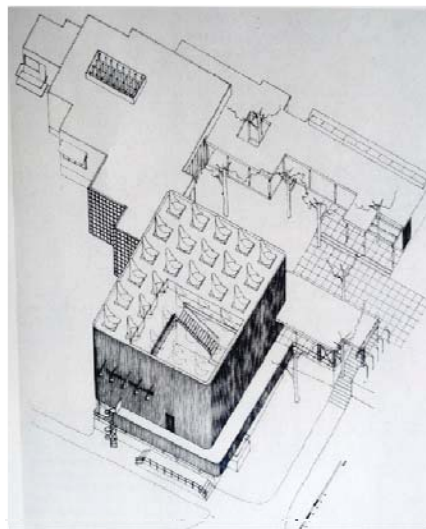

V 37 a b

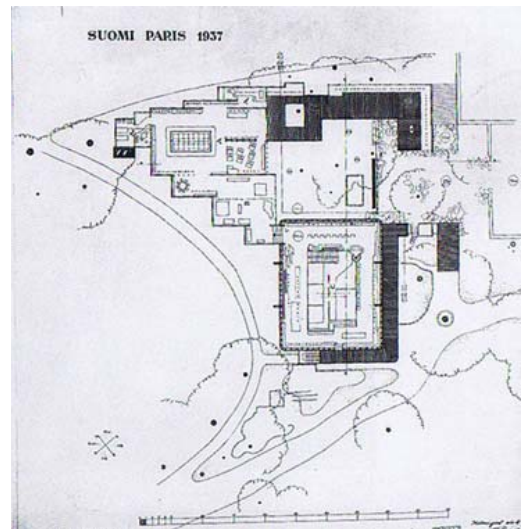

V 38

FIG 37 a,b- Pabellon of Finland, 1937, Expo Paris, Aalto, AAA

FIG 38 - Model building for Turin, unrealized, Aalto , Asource: Schildt,1994

FIG 39 - Maison L. Carre, 1957-1959, France, Aalto

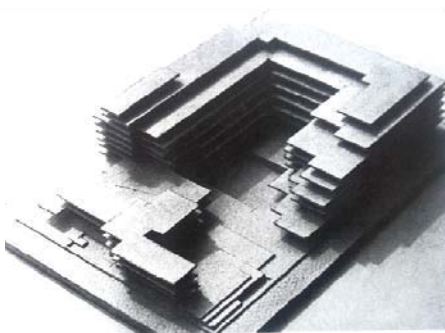

V 39

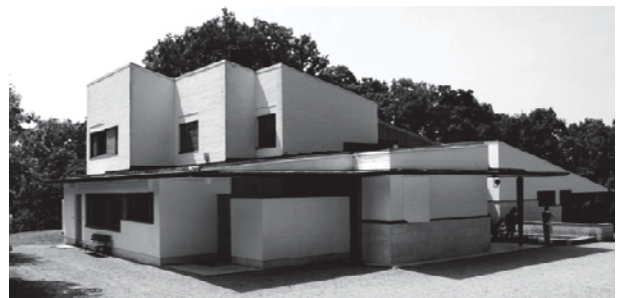

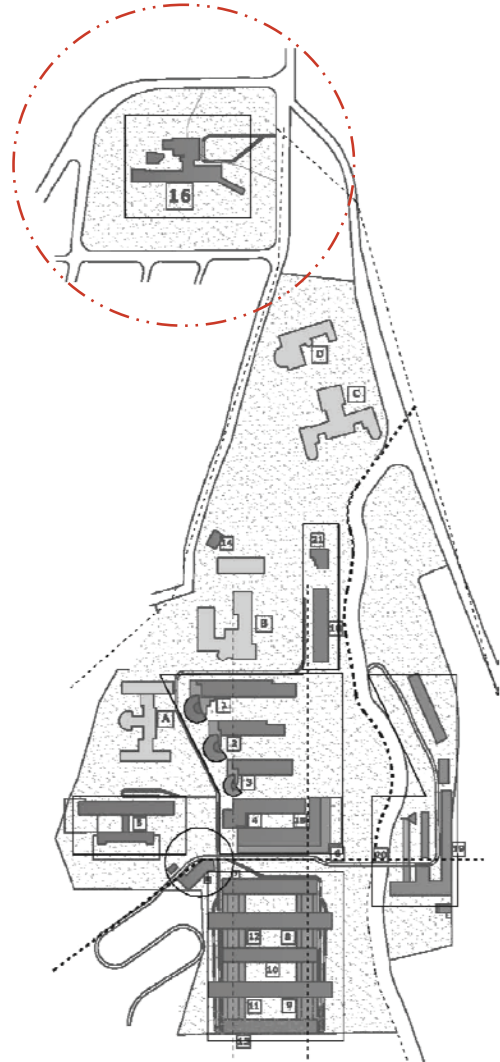

ZONE 6 Sanatorium

Interactions with Sanatorium in Paimio

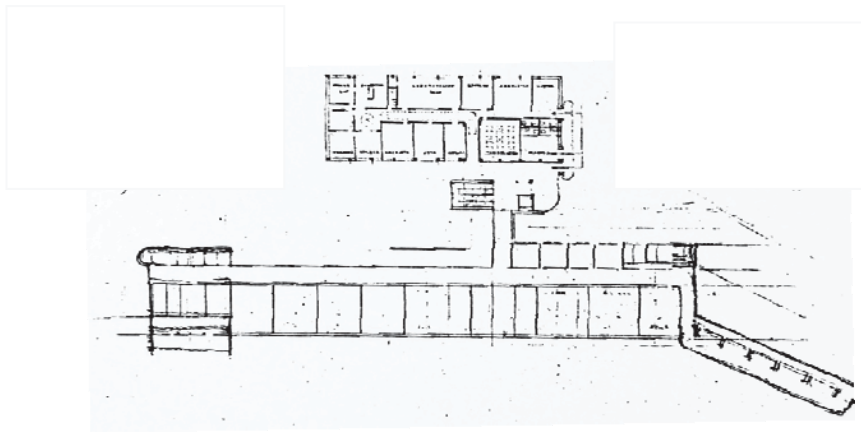

FIG S1 - Sketch of the Sanatorium of Zagreb 1930-31, Aalto, source: AAA

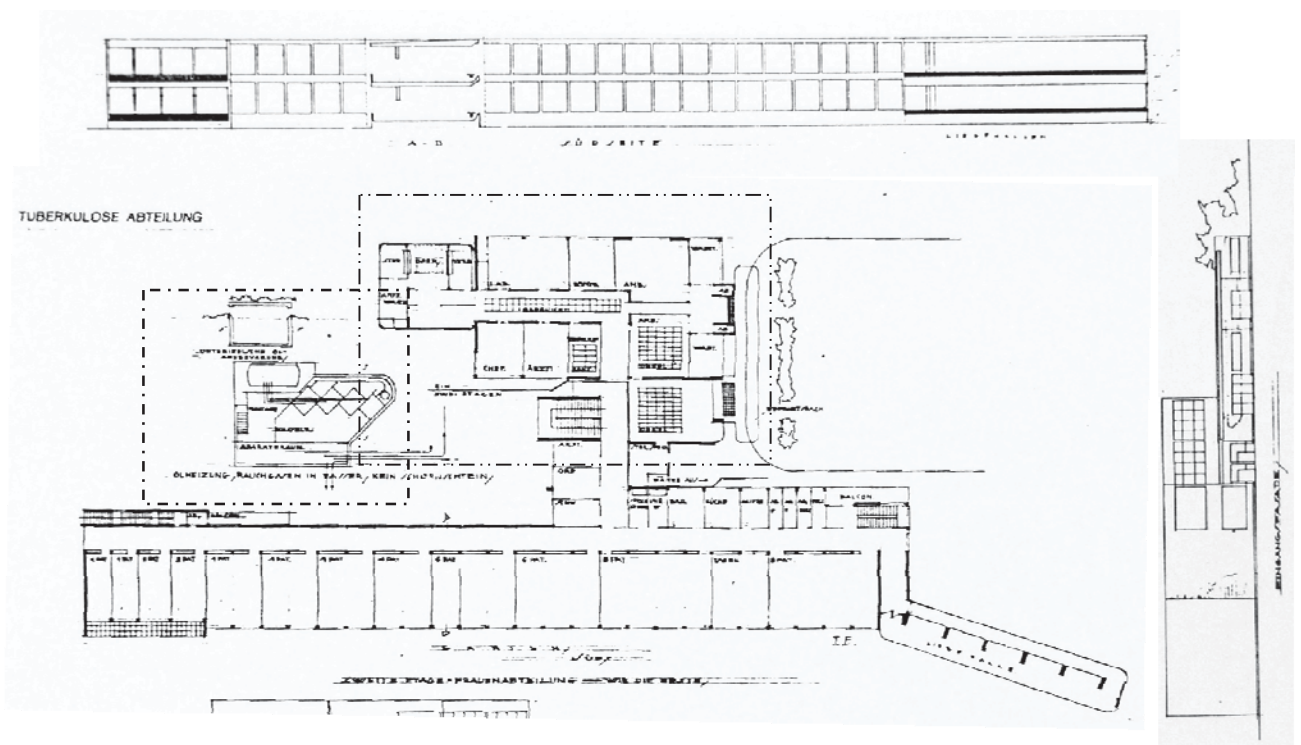

FIG S2 - Original drawings of the Sanatorium of Zagreb 1930-31, Aalto, AAA

(Floor plan, section and facades with marked annexed forms of the ground floor, developed at the same time on both projects: Sanatorium of Paimio and Sanatorium of Zagreb)

The HCZ competition program required to locate the building of the Sanatorium of Tuberculosis on the isolated lot in the north (lot no. 3), with 100 patient beds, placed one kilometer from the main part of the hospital complex on the hill (lot no. 1 and 2). This lot had all independent installations and the independent access from the city (Fig Sa). The program required the wind protection from the N and E, and independent central heating system and own distribution of warm water and steam.

By analyzing the plans of the Zagreb Sanatorium, (Fig S1,S2), we can conclude that the composition is similar to the orthogonal version of the Düiker's Sanatorium (Fig S3), and very similar to the previous plan of two main bodies of Aalto's Kinkomaa Sanatorium (1927), (Fig S4). This method is implemented previously in the Sanatorium Paimio as a decomposition made by parts. By analyzing the development and metamorphosis of the floor plan of the Sanatorium Paimio until its final form 1928-1931 (four versions) (Fig. 5 a,b,c,d), it is observed that the plan of the Sanatorium Zagreb is similar to the second version of the Paimio Sanatorium project evolution with the floor plan featuring the three bodies connected to each other by two orthogonal and one diagonal axis with the solariums (Fig S5b).

The sanatorium building of Zagreb has two main parts. The first is a two-story rectangular body of the patient rooms with a diagonal rectangular wing featuring the "trimmed" corners of the terraces-open-air solariums for the tuberculosis patients. This is followed by the two-story part of the building (alike the Paimio sanatorium).¹

In the south section of the two-story building Aalto placed patient rooms while the bathrooms, nurse's rooms and stairs are located at the north. The other part is a single level body which contains the main entrance with the waiting rooms, offices, laboratories, operating rooms, outpatient units; both connected with the perpendicular small rectangular "neck"- connector. This ground floor part includes the skylights, as well he implemented the same system in the annexed ground floor of the Sanatorium in Paimio and the extensions of the 50's.(S6c)

¹ He used the open-air spaces for the "cure" of the patients, because in the early years the only known "cure" for tuberculosis was complete rest in an environment with clean air and sunshine. For that reason Aalto on each floor of the building of the Paimio Sanatorium, and after on this Zagreb Sanatorium, at the end of the patient bedroom wing, designed the sunning balconies-long terraces, where weak patients could be pulled out in their beds

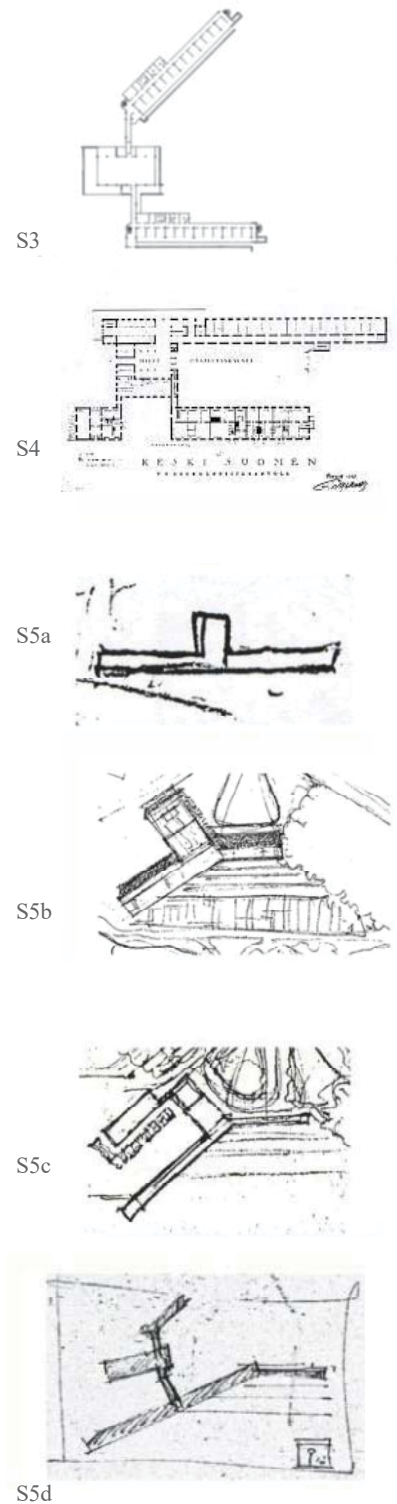

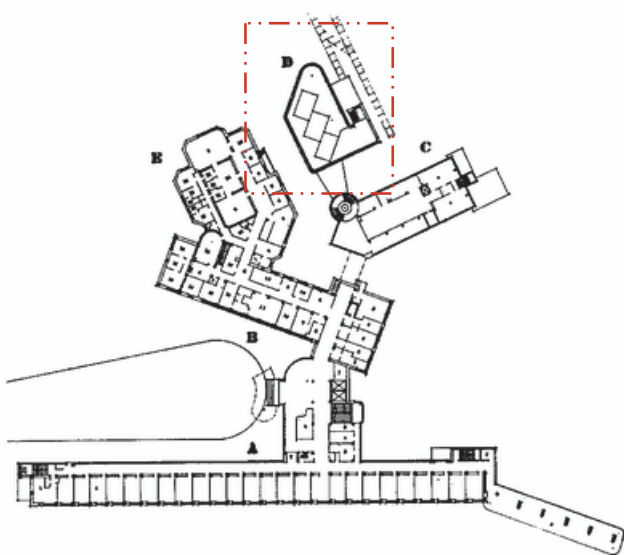

S6a

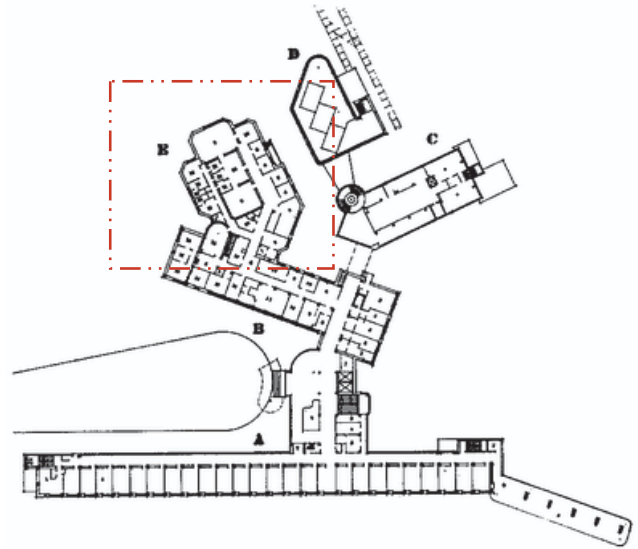

S6b

FIG S3 – Floor plan of the Düiker's Zonnestral Sanatorium building. 1925-1931

FIG S4 – Kinkomaa Sanatorium (1927), Aalto (unrealized project) , orthogonal composition made by several parts), source: Schildt, 1994a, (AAA)

FIG S5a,b,c,d – Aalto's sketches of the 4 Versions of the Sanatorium Paimio developed 1928-1929 (Sanatorium from Zagreb competition similar to the 2. version of Sanatorium Paimio), source: AAA

FIG S6a,b – Extension (annex of the ground floor) on the Sanatorium Paimio in 50's, with forms similar of the Sanatorium fo Zagreb (1930/31). Annex 1 (Fig 5a) (1930) of the Heat plant, on the drawing of the Sanatorium in Paimio, stamp with the date December 1930, just on the one no.76(june,1930), Annex 2 (Fig 5b) (1950's of the office spaces, laboratories and other necessary spaces placed in the ground floor).

FIG 6c – Photo of the Annex 2, added in 50's by the Aalto office , annexed part of the ground floor of the Sanatorium in Paimio, very similar to the one of the two bodies of the ground floor of the Sanatorium of Zagreb (where are placed laboratories, operation rooms, offices and other spaces) (view Fig S2),

FIG 7a,b,c- three final floor plans of the Paimio Sanatorium, since 1929 until 1950's (Fig S7c) (extensions, annexed ground floor)



S6c

In the first development of the sanatorium floor plan, Aalto placed the inclined composition of the floor plan, analogous to the Sanatorium Paimio building. However, the program of the competition required the orientation of the all patient rooms toward the South. For that reason Aalto changed the main position of the sanatorium floors with the patient rooms to the south, orthogonally. When Aalto started this project, he had already won the competition for Paimio Sanatorium (1928-29). It is sure that Aalto was very satisfied with this project, being a symbol of the therapeutic architecture and wanted to reinterpret the analogous project in other sites with similar conditions and uses. He even took a part in several competitions for hospital design after Paimio Sanatorium, but he was not awarded with any project realization with the same function. Simultaneously with this competition of the HCZ (developed since August 1930- January 1931), Aalto was realizing some modifications and extensions of the project of the Sanatorium in Paimio² where he has presented the final version of this project in 1931.³ There, we can find some interactions and cross-influences between these two sanatorium projects, where next to the ground floor body of the Zagreb Sanatorium building he developed the annex of the heat plant of the buildings which Aalto also integrated into the ground floor of Sanitarium Paimio, the same year 1930⁴, (Fig S6a). Moreover, in 50's Aalto conducted few extensions of the annex forms on the ground floor for the Paimio Sanatorium⁵ (Fig 6b, c, Fig S7a, b, and c). In Fig. S7c can find many similarities of the ground floor main body with the hospital spaces of the Zagreb sanatorium (with the entrance, outpatient units, laboratories and offices).

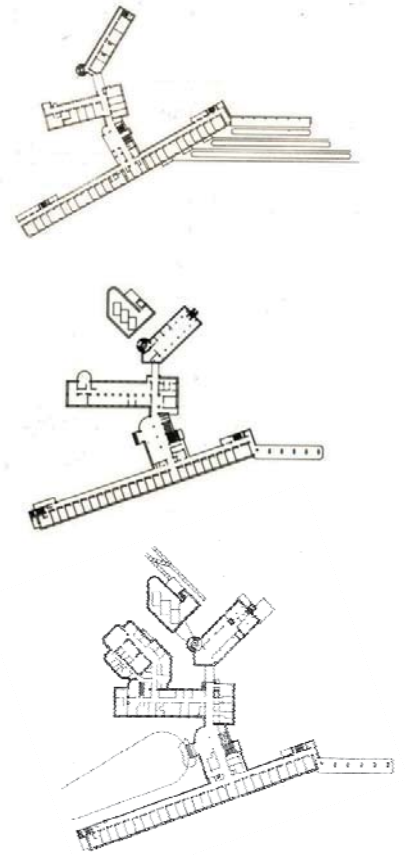

S7 a,b,c

² Aalto made four main variations until 1931 and he modified the principle competition entry. Also he added the residential area of the Hospital complex in Paimio which he developed until 1933 where also its observed many interactions between both projects which developed at the same time (Buildings type I and II of the residential area of the Zagreb hospital complex. This residential zone and the interactions with the residential zone of the Sanatorium Paimio had been analyzed in the chapter of "Residential and administrative area", residential buildings Type Ia and Ib of the Competition entry of the Zagreb hospital complex)

³ Also in Biurrun, F.J., Closa, M., Linares, A.- El Sanatorio de Paimo, 1929-1933, Alvar Aalto, Departamento de Proyectos Arquitectónicos de la UPC, Servei de Publicacions de la UPC, Barcelona, 1991. comparison of the angle and position of the "bodies" of the spatial organism of both sanatoriums on the site

⁴ In almost all drawing of this annex of the heat plan of the Paimio Sanatorium (stamp with the date Decemeber, 1930), just one with the some date of June, its not sure, but probably it could be December, 1930.

⁵ Modifications and extensions of the Sanatorium in Paimio History until now, we can find that information from many authors and also new information about it in Review Arkkitehti 2009, Article of Esa Laaksonen where he treated the theme of the Sanatorium Paimio transformations from the realization until now.

CONCLUSIONS

The main results of this study are:

1. the synthesis of the new principles (as the base of active power – methexis) , their possible origins and meanings, as the important components of the Aalto's architectural language elaborated within his competition entry for the Zagreb hospital complex, Yugoslavia 1930-31. Putting the origins of Aalto's architectural language in the specific context, we can comprehend the importance of the evolution of the Aalto's architectural language compared with the processes of Nature. The purpose was:

2. define the contexts and factors that influenced the creation of New Architectural Principles-components of the beginning of the Aalto's architectural language creation; origins, genesis and also their impact and sustainability, applied to the later works as an external or internal component of the compositions (as in the nature "edge species"- "external species" or "internal species" inside the one "ecosystem" and the distance and space between the "species"),

3. analyze some ways where appear these new components – principles as the variations in many of Aalto's later works, where many of these reflected elements-principles (from the HCZ competition), as variations in later works of the architect can be seen as a universal substance which gives balance to all requirements. That universal substance contains different components of the "primitive", "everydayness"¹, the best "utility" and with that atemporal components, avoids any formalism.

From this groups, at the end of the study, it is possible to extract and analyzed three **conclusion groups**:

1. NEW PRINCIPLES - origins and meanings
2. VARIATIONS - applied principles as a "universal substance"
3. NEW FORMS - between the "external" and "internal" in the later phases

¹"everydayness", from Heidegger's theory, Heidegger Martin , *Being and Time*, John Macquarrie & Edward Robinson (trans), London: Blackwell Publishing Ltd, 2000

1. **NEW PRINCIPLES:** The current study focuses on this genesis and main possible origins and meanings of some important new principles, born in an authentic way in this extensive Aalto's competition entry for HCZ, like the one of the main origins and drives of Aalto's inventive architectural language.

The zones of the whole hospital complex of Zagreb and factors (permanent and variable) that influence the creation of the Aalto's new "principles":

Zone I

1. **"Head and Body "in Bio-dynamic movement and**
2. **"Amphitheatre"**
Factors: a. program- function, b. built context – site; c. climatic conditions d.natural context, e.context of the city-views dialogue,f.subconsc./ unconsc./metaphoric as a human body in movement with three components of the composition head+neck+body²
3. **"Rectangular" auditorium as "Transitional form"** correlated with Amphitheatre
Factors: a. program-function and b.climatic condition and natural context c. context-site, d. context-city-views –dialogue, e. subconscious/metaphoric
4. **Multiplication of the "same species", decreasing order**
Factors: a.program-function, b. context - site, c. climatic condition, d.natural context,e. context–city–views dialogue, f. subconscious/metaphoric
5. **New Daylight techniques:** 5a.b. - "Upper windows and double sources of light of the amphitheatre", 5c-extended angle of the light of the patient room
Factors: a.program function, b.comfort, c.climatic condition
5.d. Daylight system on the stepped vertical plane
Factors: a.program-function, b.comfort, c.natural context -configuration of the terrain, d. context-site, e.context-city (main road)

Zone II

6. **"Backbone"**
Factors: a. program-function, b. climatic condition, c. new technologies in the construction and health conditions, d. built context-site, e. natural context- configuration of the terrain, f.context city-views, g. subconscious/ metaphoric meaning

² Aalto also permanently linked his design process on subconscious level with many associations from his background of the experiences, associations from his interactive memory, arts and other influences.All that influences together constitute a base: "METHESIS"- as a "... Power that enable something to happen or come into being". (Wilson,1995)

Zone III and IV

7. **"Stepped in the vertical plane correlated with the ground"**

Factors: a.natural context -configuration of the terrain, b.context city-views dialogue, context-site, c.program-function, d.climatic conditions, e. subconscious/ metaphoric meaning

Zone V

8. **"Stepped in the horizontal plane"**³

Factors: a.climatic conditions b. program-function, c. comfort, privacy, d. natural context, e.context-city, f. subconscious/metaphoric meaning

It is possible to relate the origins of these Aalto's new "principles" with the specific use and the HCZ site conditions: natural and built environment, climatic conditions, dialogical relation with the city which are apparent in his HCZ entry and lead along the Aalto's trajectory, together with all previous experiences of the architect (creation sources based on the associations of the hermeneutic subconscious level and his interactive memory). These ideas – new principles, from this unrealized competition project formed the *Methexis*, active power which enables something to happen, or linking with the Architecture and hermeneutic process **"Architecture represents the possibility for the action."**⁴

Knowing this specific context, where some significant elements of Aalto's inventive architecture language are born, we can re-conceptualize our knowledge about them as "principles" and gain more information about their true origin and their genesis and evolution in his other works and contexts. Followed the own Aalto's theories, these new components of his language emerged together in this competition entry with a specific function and the encounter with influences from a variety of contexts in a broader sense.

Just a few months before the Zagreb hospital complex competition in 1930, Aalto with Aino organized Helsinki residential exhibition and in *"Minimum Dwelling Rationalization Section of the Arts and Crafts Exhibition"*, where he said:

³ G.Shildt, mentioned the residential tower of the competition entry for Zagreb with some influence, but was not analyzed general,as the one of Aalto's new principles, observed in his residential and non residential buildings. .

⁴ Muntañola Josep, *Arquitectura y Hermenéutica*, Edicions UPC, Barcelona, 2003., p.49

"Only where a form arises at the same time as content or in faithful combination with it, as it were, can we speak of a step forward, but then form as separate element no longer interests us".⁵ In this vast Zagreb hospital complex competition entry, had to be resolved one new "hospital city" with many different functions "contents" (clinics, hospital, residential, service, administrative, industrial areas with very complex traffic functions) and together with the different contexts, this project gave a birth to big "diversity" of the forms and principles.

This site of the competition on the hill next to the city centre, which Aalto called "Acropolis", was the perfect base for the inspirations and creation of "**new species**" as the components of his "**Natural Urbanism**".

Aalto said about hills city and natural Urbanism, after his travel to Italy 1924:

"City on the Hill has acquired, in another sense, a new value for me: it is the purest, original and natural variant of Urbanism, and, it's natural beauty is the most beautiful man that can perceive at ground level. Man captures this vision as a harmonious whole and integrated, consistent with its own size and its sensory limits"⁶

All these words described Aalto's composition of the hospital complex on the hill: **A new value - purest – original - natural variant of Urbanism - natural beauty - man, can perceive at the ground - man captures this vision - harmonious whole - integrated - own size - sensory limits**

The natural context of the site of the competition, also make possible this "biodiversity" as "arch-diversity" where we can connect the Spatial Theory from the nature with genesis of the main principles of the Aalto's architectural language where it is observed this phenomenon of the form diversification on the hill, with the **Edge effect** between the two contexts, as two ecosystems in Nature. Frequently residing within the limits of the context of nature, we find more "arch-diversity" as

⁵ Aalto Alvar, Minimum Dwelling Rationalization Section of the Arts and Crafts Exhibition", 1930. Aalto wrote this just few months before this competition of Zagreb hospital complex, for the Minimum Dwelling Exhibition (1930, Exhibition held in Helsinki few months before this competition)

⁶Journey to Italy Casabella Continuita, 1954 (published in Schildt,"A.Aalto de palabra y por escrito",El Croquis Editorial, 2000, p.58 (own translate,Spanish version)

“bio-diversity” on the limits, as in the case of the site of the competition on the hill between the city context and next to the old medical campus complex on the site. *Edge effect* with the biodiversity can connect with the diversity of the “ideas” (in Plato’s sense of the substantial idea-form) on the limits of the hill. From the reinterpretations of the formal characteristic of the natural “border” it is possible to understand the natural process of the formation of “*Ecotone*”, an intermediate zone between the two different ecosystems in Nature, between the two “contexts”.

Ecotone – “transitional area”⁷ between two ecosystems where one ecosystem obtains properties of the other where they meet and integrate. Following the Tobler’s “first geographic law”: “*Everything is related to everything else, but near things are more related to each other*”⁸ we can also connect this Tobler’s theory with the existing built context and Aalto’s new ideas, as the correlation between the components of the new complex and the natural and built base of the competition site on the hill.

When we deal with the function in the Aalto’s work, we need to consider all psychophysical effects (most important in the hospital buildings). Aalto stressed about the function in the Functionalism and International Style: “*Architecture is not a science. Still the great synthetic process of combining thousands of definite human functions (...) Functionalism is correct only if it can be extended to cover even the psychophysical field*”.⁹

Eight new principles from this HCZ competition project are formed together in one specific context, respecting all needs of the human functions and accordingly to the conditions of the competition. This process of the creation includes the conscious level and all other experiences as the part of the interactive memory, on the subconscious level; all necessary for the creation of the “principle” in the broad meaning.

⁷ Graves, R, *Ecotone*. Retrieved from <http://www.eoearth.org/view/article/152345>, 2011

⁸ Tobler Waldo, *A computer movie simulating urban growth in the Detroit region*, Economic Geography, 1970

⁹ Aalto Alvar, *Humanizing Architecture*, 1940, ed. Schildt G., *Alvar Aalto Sketches*, pp. 77-78

We can distinguish these two important components with both principles C1 and C2 which intertwine:

C1. New forms and principles as the answer of the specific functions together with the psychophysical effects (human needs).

C2. New forms and principles from the dialogic image with the existing context: natural context (together with climatic conditions) – built context of the site – city context /conscious level/ understanding with all other contexts /subconscious level.

After the analysis of the complete Aalto's works throughout his career, where he applies these principles, we can deduce that they are applied, with different variations, as a "**universal substance**" that gives harmony to all elements of the creative process (e.g. the form of the "amphitheater" used as the: Lecture Hall of the University, Library Hall, Auditoriums, Acoustic rooms of the Church or Concert Hall).

The ways and strategies that may appear applied in a very similar way meet the different functions in different works. Although very similar form, implemented in two different works with different context and function, was applied as the "universal substance", which gives the best solution to various requirements for some functions that need to be met simultaneously.

By analyzing these new composition forms, it is possible deduced that they are not only functional but also responsive to the natural context, built context, visual, physio-psychological and symbolic meanings. For the complete analysis of this applied element, it is very important to know the origin of this "universal substance", which meets the other functions in different works as a permanent motive of Aalto's trajectory. This implies similar formal characteristics, but with many different functions and other reasons of the existence.

Juhani Pallasmaa wrote about these elements of the Architecture: "The "elements" of the architecture are not visual units or *gestalt*, then are encounters, confrontations

that interact with memory. "Architectural space is *lived space* rather than physical space, and lived space always transcends geometry and measurability".¹⁰

It is observed in this analysis that elementary components of the Aalto's architectural language in the Zagreb competition entry were born in the historical context together with the effects of the spatial theory of the natural context and subsequently these elements are transformed along Gideon's space-time, primarily served the function.

Genesis of the ideas from the previous historic context, developed along the ahistorical frame, served for the function, avoid any Formalism using these main elements which already contain the "historical component" of the architectural language, as the *Methexis*: "...The power that enables something to happen or come into being"¹¹ and Platonic form or idea as the "universal substance" to provide the balance between the different requirements. Aalto explains his project process,¹² where with an important subconscious component during his creative design process, came up with the "universal substance" which gives balance and a solution for all functional problems¹³; which also avoid any formalism with usefulness and adaptability.

In the case of the project in Zagreb, this NEW PRINCIPLES were formed in most buildings of the complex as separate individual units or functional areas. Therefore, they are a reflection of pure - "primitive" - elementary components of the Aalto's architectural language.

By analyzing the projects implemented after this competition entry (1930-January 1931), it is noted that their VARIATIONS contain one synthesis of several principles from this competition entry, applied together, which give "more" formal complexity

¹⁰ Palasmaa Juhani, *The Eyes of the Skin: Architecture and the Senses* (Academy, 1995 and John Wiley & Sons, 2005), p.63-64

¹¹ Wilson, 1995, p.41

¹² That design creative process Aalto explained on the example of the Viipuri library, realized at the same time with this competition entry of Zagreb, where he was in the process of the transformation of the main ideas of the Library from the classical composition 1927-1935

¹³ He explains this creative process with important subconscious component in: Aalto, *The trout and the stream*; Domus, 1947

increasing up during Aalto's trajectory to third level in the later phases and the creation of the "NEW FORMS". That is other, 3. group of the conclusions of this research results throughout the study and the first two groups: 1. New Principles and 2. Variations, indicate that Aalto's language was formed from the beginning with the elementary forms as "...the masterly, correct and magnificent play of masses brought together in light"¹⁴, and that the main variations in future Aalto's works are based on the combination of the two or more new principles (exterior) applied together for the primary functional reason (interior).

Many of that main principles, which "live" as the one individual unit with the one function in this Aalto's project, and principles applied along his previous experiences, are converted to the annexed forms of the ground floor or the façade and integrated together with the other principles, where always cause different visual sensation of fulfilling the primary function in his future works; for that is possible to understand the future compositions based on these first principles as a symphony.

Analysing Aalto's new components of the architectural language of this competition entry, together with previously implemented elements and comparing with their future variation along his trajectory, it is observed that Aalto after this initial phase converted the simple forms from the second half of the 20's and 30's to the main elements of his architectural language - "*leitmotifs*".

However, after numerous variations of these principles he creates other, new forms, not based more on the first combinations of these elementary forms and in the last phases, these variations culminated with the one dominated radical transformation of the shape segments making each time more complex "new forms". In this competition entry, we can recognize forms of the ancient world, Radiology centre as the Ziggurat, Lecture Hall of the University of Medicine as the Amphitheatre, Service area on his early sketches as the Hatshepsut Palace of Egypt or residential tower as the part of the Greek column. All of these forms, in the one simple way by the use of the elementary forms, gain the monumentality and correlated with the contexts.

¹⁴ Le Corbusier, *Vers Une Architecture*, 1923

Aalto's sensations created the forms which can be related to Heidegger's everydayness and the "primitive", evident in the old architecture where with the very simple form one lecture hall is converted to the "sacred temple". An Amphitheatre in his works conserves the elementary primitive form and primary function as the metaphorical genesis of the form alike the desire of the people to express (as the lecture hall, lecture room of the libraries, town hall, cultural centers, concert hall or the church space).

Alvar Aalto stressed at the one conference when he was asked why he does not make more free-form designs (like the undulated forms) of the Pavilion in New York: *"I have not had suitable building materials"... "we cannot create a free-form architecture with standard elements. A rectangular brick is not suitable"*.¹⁵

The example for this is the famous undulated Student Residential building of the Campus of MIT, which was first made as the "stepped" form in the horizontal plane and applying the principle of the "backbone" composition with rectangular parallel pavilions. However, the awarded option was the undulated form, preferred by the management of the University.¹⁶

Implementing of these elementary principles together as a "symphony", Aalto often added the very complex annexed forms of the ground floor plan for the different functional requirements. In the unity of the previously associations from the interactive memory with all his experiences for each function – "principles" as the "universal substance", which give the harmony of all elements, in the later phases he developed more complex forms in the horizontal plane applying many of these principles together as the one unique mega-conglomeration.

¹⁵ Schildt Goran , *Alvar Aalto Sketches*, The MIT press Cambridge, Massachusetts and London, 1978

¹⁶ Willson St John Colin: *The Other Tradition of Modern Architecture. The uncompleted project*, 1995, p.100

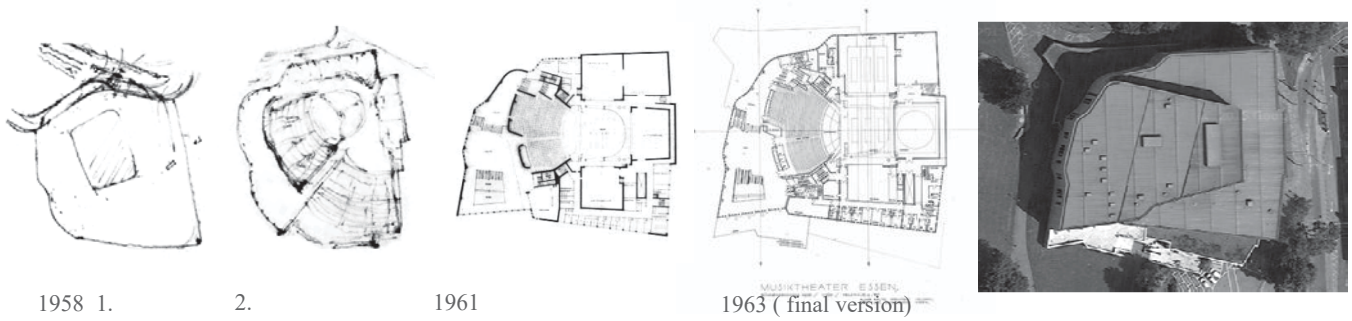

C1.Genesis and metamorphosis of the floor plan of the Opera Essen

By analyzing the genesis of these principles in other projects, as a synthetic forms developed of the **exterior components**, which in the **first phases** also have the **application on the exterior**, it is observed the different process of the cyclic process from the later phases where Aalto creates "new forms", not based anymore on elementary components from the beginning of the creation of his language. That **cyclic process** of the **genesis of the "new forms"** with more and more **complexity started with the previous first idea (exterior) to solve the functional problem inside, came from the exterior – applied in the interior (functional) and again back to the exterior but this time transformed, and the same "exterior idea" passed to be "interior idea" adapted to different functions and internal routes.**

In the nature, between two ecosystems occur the phenomena **on the "edge"** (limit - "edge" produced in the natural way or by the human), forming the **"edge effect"** and **"ecotone"** with the characteristic species in the exterior, **"edge species"** and another kind of the species in the interior. With the affectation and fragmentation of the ecosystems and with the creation of the many new "ecotones" and "edges" in the ecosystems (contexts) increases the concentration of the species on the small spaces between the borders-limits of the space formed by new "edges".¹⁷

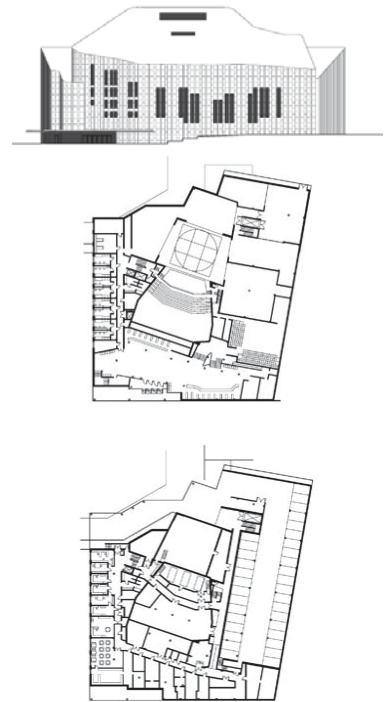
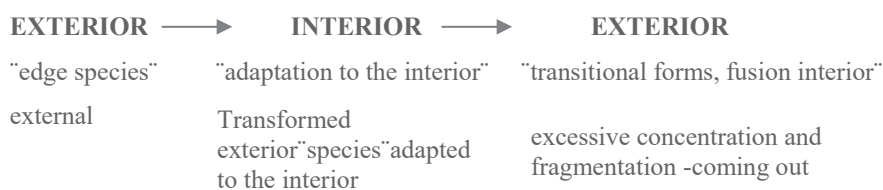

FIG C1- Essen Opera house, Aalto. Metamorphosis of the floor plan (1958-1963), source: AAA Google Earth
 Façade, source:F.Alvarez, <http://www.historiaenobres.net>, visited 7.10.2015.
FIG C1a – Theatre Jyväskylä, 1964, Source: F.Alvarez, "HO", "Historia en Obres"<http://www.historiaenobres.net>, visited 7.10.2015.

¹⁷ Graves, R. (2011). *Ecotone*. Retrieved from <http://www.eoearth.org/view/article/152345>

These spaces from the interior can survive in the interior habitat, but moved on the edges in the exterior only some species and exemplars can survive. **CYCLIC PROCESS OF THE FORMING OF THE "NEW FORMS" IN THE LATER PHASES OF THE AALTO'S TRAJECTORY**, using these first components - "principles" from the beginning of the creation of his architecture language



Scale of the probability of sustainability of the "species":

- New Principles - "edge species" - sustainable and integrated with all factors (function, context, genius loci, all adapted to exterior form and interior function).
- Variations - "edge species in the interior"- where survive "interior species" as the "interior forms" and "universal substance" without an excessive augmentation of the concentration and complexity made with the fragmentation. Born as the external:
 - "edge species", but adapting to the best function in the interior was converted to the "universal substance" to solve all conflicts inside the "limits".
 - Example of that is depicted in the idea of the creation of the Viipuri Library central hall interior, taken from the exterior imaginary hilly landscape, but as a universal substance resolves all problems and conflicts. That process depicted also some Aalto's works from his latest phase where it is observed the cyclic process from these principles and genesis of the "new forms".

By analyzing many of Aalto's later works, it is observed that the complexity increases until the latest phases (from the first ideas of HCZ competition), because later derivations of the first principles in his works combine several principles connected in one unity and one context and these principles were previously applied individually as elementary forms in the buildings of the HCZ Aalto's competition entry and each one with own different context.

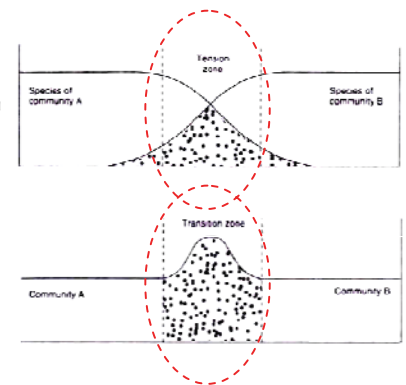

FIG C2 -Ecotone - "Tension"
 Between two context-two
 ecosystems, increasing
 density of the "species"
 Excessive number: "coming
 out"

The buildings between the "borders" could be observed each one as one ecosystem in nature, so its fragmentation, increasingly visible in the final phases of Aalto's trajectory, reducing the distance between species (principles applied) and increasing its density (each fragment of the composition of the floor plan can understand as another ecosystem). This increase of species cause that these principles ("species") "coming out" from the "border" to "outside".

Analyzed the new principles, were born "outside" (in the HCZ Aalto's competition entry), as the "edge species" and in the later works moved to the interior (as "interior spaces"), these future forms are the synthesis of the many of his principles together, especially observed in the later phase.

Connecting these processes of the creation of the Aalto's architectural language and implemented in Zagreb project, with the processes of nature and the Spatial Theory and its phenomena of "edge effect" and "ecotone" (transitional zone of the "tension"), which occur between different ecosystems-contexts along the border and within the system it could follow the scale of the sustainability of these elements depending on their place of birth and subsequent application-use, outside-'border' or in the interior (inside the border -"habitat"), and the way of use of the main principles as the future derivations- variations on other Aalto's works.

It is observed complexity and fragmentation (many "ecotons" with high density of "species"- principles), with the high concentration of the "species" (principles in the building floor plan applied all together). These "species"- principles coming out as "interior species" from interior space -"habitat", no like a "edge-species", where are born in the early stages, these species-principles, and we might conclude that the sheer complexity of the plant is sustainable with the proper use of sufficient distances between spaces (fragments) of the interior, without extreme fragmentation and inflections. However, the outward forms are more sustainable as "elementary" forms, with less complexity of fragmented lines, discontinuities, waves in the interior, because the species formed in the outer border (context-site) are sustainable on the "edge" with fragmentations inside the building, but once converted into interiors, when they again go outside transformed, have less chance of sustainability.

Moreover, in nature, with increasing the density of the species "principles - formal-compositional" inside the building (habitat), then at the edges (edge of the building – facades) decreases the density of the "species". Transferred that from laws of nature to the compositional and formal principles of the Aalto's architectural language, it is possible to understand that the fragmentation affected the interior spaces with increasing the number of the "species"- new forms applied inside in one reduced space.

As it is observed in the composition of the Surgery Clinic of the HCZ Aalto's competition, where he applied few principles together on the ground floor: as "head and body in movement", amphitheatre and stepped annexed form in the horizontal plan, more flexions are observed in the outlines of the annexed parts of the ground floors followed the function with all necessary spaces. This phenomenon of the most complex contours with more interventions in the annexed parts of the ground floor is sustainable in less high level (ground floor) because can be represented the ground-base, with natural "borders" and contrasting borders caused by the human of the straight lines "limits". Observing many Aalto's works with applied auditoriums –amphitheatre with irregular forms (with many, discontinuities and flexions) could be imagined as the boundaries on the map of the city, as in the example of the Auditorium with irregular forms of the Urban Centre in Rovaniemi (1963) alike the map of Rovaniemi.(Fig C3-C4) Annexed part of the ground floor in the final phases of the Aalto's trajectory can be observed as the limits of the "site"- ground, and parts of higher plants grow from this base with more simplified forms.

The results of this research may open the way for more detailed future analysis about the principles of the Aalto's architectural language and allow the different connections with later realized Aalto's works important for better understanding of his trajectory and for the wider frame of the architecture of modern movement considering all influences until today and also more detailed research about the theme commented in this last part of the connection with the spatial theories, and relation between exterior-interior-exterior as the cyclic process of the new forms genesis.

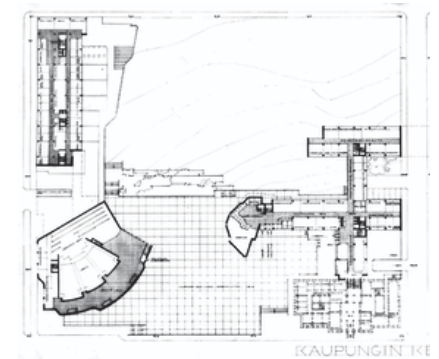
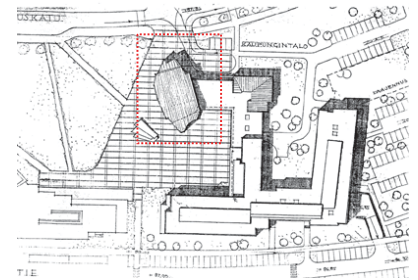

FIG C3 Auditorium Rovaniemi Urban center Rovaniemi, 1963, AAA, source: Fleig,K (1995), AAA

FIG C4- Map, possible borders of the zone, very similar to new forms, source: *Google Earth*

FIG C5-Auditorium of the Cultural Centre of Jyväskylä (1964) (on the left side), have two facades, one annexed- edge – limit, as a border in nature, and other inside, which grow above the ground floor (the base-ground),,source: Schildt 1994a, AAA

**CONCLUSION : NEW PRINCIPLES. AALTO'S SYNTHESIS OF THE
NEW IDEAS- PRINCIPLES ON THE REVERSE SIDE OF THE MAP OF THE CITY**

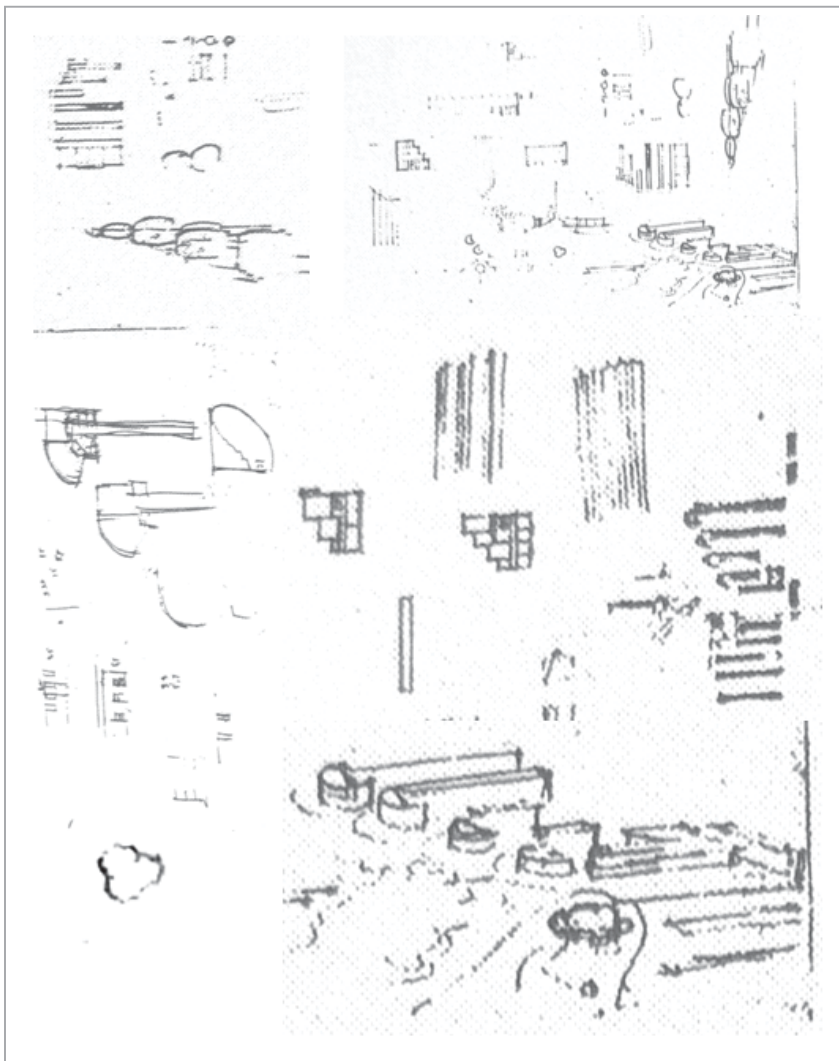

FIG C6.- Collage of the Aalto's sketches, made by author of the thesis, from the paper, 50/608b (AAA)(on the reverse side of the paper of the Map of Zagreb delivered with all documents of the competition on the large format), source of the sketches from 50/608b, AAA, collage of the segments of the Aalto's sketches

C6

BIBLIOGRAPHY

Aalto Alvar, *Zagreb sairaalaryhman kilpailuehdotus*, Arkkitehti XII-1932, SS 5-6 , 1932

Álvarez P. Fernando, *Alvar Aalto: Ajuntament de Göteborg*. "Història en obres", December 2010, vol. 4, núm. 4, p. 312.

Bajtín Mihail, *The dialogic imagination*, University of Texas Press, Austin, 1998

Biurrun, F.J., Closa, M., Linares, A.- *El Sanatorio de Paimo, 1929-1933, Alvar Aalto*, Departamento de Projectos Arquitectònics de la UPC, Servei de Publicacions de la UPC, Barcelona, 1991.

Bjazic K. Tamara, *Zagreb Group-Foundation and Public Activities in Croatian Cultural Context*, Prostor, Zagreb, 2005, p.41-51

Bjazic K. Tamara, *International Competition for the Foundation Hospital and the Clinics of the School of Medicine in Zagreb, 1930-19*, Prostor, Zagreb, 2012, p.283-295

Blau Eve, Rupnik Ivan, *Project Zagreb: Transition as Condition, Strategy, Practice*, ActarBarcelona, New York, 2007.

Bray Roberto, *Alvar Aalto: spazi e processo architettonico*, Dedalo, Bari, 1984.

Brosa Víctor (ed.). *Alvar Aalto*, Ediciones del Serbal, Barcelona, 1998

Capitel Antón, *Alvar Aalto : Proyecto y Metodo*, Ediciones Akal S.A, 1999

Capitel Antón, *La arquitectura compuesta por partes*, Gustavo Gili, Barcelona, 2009

Cohen Jean-Louis, *Le Corbusier and the mystique of the USSR : theories and projects for Moscow 1928-1936*, Princeton University Press, New Jersey,1992.

Cooke Catherine, *Architectural Drawings of the Russian Avant-Garde*, Museum of Modern Art New York, 1990

Domínguez M. Luís Ángel, *Alvar Aalto : Una arquitectura dialógica*, Edicions UPC, Barcelona, 2003.

Duany Andres. *Principles in the Architecture of Alvar Aalto*, The Harvard Architecture Review, 1986, núm. 5.

Dunster David, *Architectural Monographs 4 Alvar Aalto*, Academy editions: St.martin's press, New York, 1978.

Ferrer Jaime, *Alvar Aalto and Jean-Jacques Barué*, Alvar Aalto Museum, 2012

Fleig Karl, *Alvar Aalto Band I 1922-1962*, Verlag für Architektur Zürich y München, 1983.

Fleig Karl, *Alvar Aalto Obras y proyectos*, Gustavo Gili, 1998.

Fleig Karl - *Alvar Aalto Volume I (1922-1962)*- Birkhauser- verlag für Architektur, 1995

Fleig Karl - *Alvar Aalto Volume II (1963-1970)*- Birkhauser- verlag für Architektur, 1995

Fleig Karl - *Alvar Aalto Volume III Projects and Final Buildings*- Birkhauser- verlag für Architektur, 1995

Fox Warwick., *Theory of General Ethics*, The MIT Press, 2006

Galovic Kresimir, "Prve globalne arhitektonske zvizde", Vijenac, no 185, Zagreb, 2001

García R. Ismael, *Alvar Aalto y Erik Bryggman: La aparición del Funcionalismo en Finlandia*, Instituto Iberoamericano de Finlandia, Madrid, 1998

Giedion Sigfried. *Space, time and Architecture: The Growth of a New Tradition*. Cambridge: Harvard University Press, 1941. 5o ed., revisión ed. Cambridge: Harvard University Press, 1967. Giedion Sigfried, *Espacio, tiempo y arquitectura*, Ed.Científico-Médica, Barcelona, 1968

Giedion Sigfried. *Alvar Aalto*, The Architectural Review, num. 2., 1950

Gutheim, Frederick, *Alvar Aalto*, Ed. Bruguera, S.A., Barcelona, 1960

Heidegger Martin, *Memorial address in Discourse on Thinking*, trans. J. M. Anderson and E. H. Freund, Harper and Row, New York, 1969

Hewitt Mark A., *The Imaginary Mountain. The Significance of Contour in Alvar Aalto's Sketches, Perspecta*, 1989, n 25

Hipeli Mia, Alvar Aalto Foundation, *University of Technology, Otaniemi 1949-1974 Vol 13, Alvar Aalto Architect*- Ram distribution, 2008

Hrausky Andrej, *Aaltov natjecajni projekt za Zagreb*, *Covjek i prostor*, 43 (3-4): 48-50, Zagreb, 1997.

Koho Timo - *Alvar Aalto Urban Finland*- Finnish Building Centre, 1995

Kopp Anatole, *Constructivist Architecture in the USSR*, Academy Editions, 1985

Laaksonen Esa, *Zagrebin sairaalan kilpailu 1931 - Alvar Aalto. Architectural competition for the Zagreb hospital 1931*. *Arkkitehti*, Vol. 106, n. 3, 2009, p. 86-87

Laaksonen Esa, *Draw in Sand unrealized visions by Avar Aalto*, Museum of Finnish Architecture, 2002

Laslo Aleksander, *Alvar Aalto Podijeljene Muistot /Divided muistot*, *Oris*, no 29, Zagreb, 2004., p.110-131

Le Corbusier, *Vers une Architecture*, Editions G. Crès et Cie, Paris s.d. ,1923 (ed. Le Corbusier, *Toward an Architecture*, Translated by John Goodman, Getty Research Institute, Los Angeles, 2007)

Lodder Christina, *Russian Constructivism.*, Yale University Press, New Haven - London, 1987

Martinez Sisniega Gerardo, *El Hospital como proyecto*, Tesis doctoral, UPC, Cataluña, 2001

Menin, Sarah; Samuel Flora, *Nature and space : Aalto and Le Corbusier*, Routledge, London, 2003

Mikkola Kirmo. *Alvar Aalto and Town Planning. Genius Loci / Town and its' plan*, Helsinki ,1980

Mikkola Kirmo. *From the technological to the Humane: Alvar Aalto vs. Functionalism*. Abacus/Museum of Finnish Architecture Yearbook, 1979.

Miller, Williams. *A thematic analysis of Alvar Aalto's architecture' A+U*, vol. 10, num. 109, 1979

Moneo Rafael. *Principios tipologicos en la obra de Alvar Aalto*. Conferencia en ETSAB dentro del ciclo *Alvar Aalto i la difusió del Moviment Modern*. Barcelona, 1980.

Mumford Erik, *The CIAM discourse on urbanism, 1928-1960*, MIT Press, Cambridge, 2000

Muntañola Josep, *Alvar Aalto. Khora 6*, Edicions UPC, Barcelona, 2001.

Muntañola Josep, *Arquitectura y Hermenéutica*, Edicions UPC, Barcelona, 2003.

Muntañola Josep, *Towards a Dialogic Approach to Contemporary Architecture*, Architectonics: Arquitectura y dialogía, No. 13, Edicions UPC, Barcelona, 2006

Nerding Winfried, *Alvar Aalto Toward a Human Modernism*, Prestel Verlag Munich-London-New York, 1999

Nikula, Riita, Construir con el paisaje, *Breve historia de la arquitectura finlandesa*, Ed. Otava, S.A., Helsinki, 1998

Odum, Eugene P., *Fundamentals of ecology*. Philadelphia: W. B. Saunders Company, 1953

Ott Randall. *Alvar Aalto and the Perspectival Space, A: Culture of Silence.*: Texas: A&M University, Texas cop., 1998.

Pearson David, *Alvar Aalto and the International Style*, Watson-Guption, New York, 1978.

Planic Stjepan, *Problemi savremene arhitekture*, Nakladnistvo udruzenja hrvatskih arhitekata, Zagreb(1.ed 1932), 1996, p.3-42

Plestina Lenko, *I veliki covjek je smrtan (o Alvaru Aaltu)*, Covjek i Prostor, no.279, Zagreb, 1976

Porphyrios Demetri, *Sources of Modern eclecticism, Studies on Alvar Aalto*, Academy editions 7-8, London, 1982

Porphyrios Demetri, *Heterotopia: A Study in the Ordering Sensibility of the work or Alvar Aalto*. A: Architectural Monographs 4. Rizzoli, Academy Ed., London-New York, 1978.

Quantrill Malcolm, *Alvar Aalto, A Critical Study*, New Amsterdam Books, New York, 1983

Quantrill Malcolm, *Finnish Architecture and the Modernist Tradition*, E&FNSpon, London, 1995.

Radford Antony, Oksala Tarkko, *Alvar Aalto and the expression of discontinuity*, *The Journal of Architecture*, Routledge, vol.12, Issue 3, 2007, p.257-280

Radford Antony, *Responsive Cohesion as the Foundational Value in Architecture*, The Journal of Architecture, 14(4), 2009, p.511-532

Radovic M. Darja, *Alvar Aalto: natjecajni rad za bolnicu u Zagrebu (1930/1931)*, Peristil - zbornik radova za povijest umjetnosti, no 38, Zagreb, 1995, p. 139-144

Radovic M. Darja, *Alvar Aalto for Zagreb*, PTAH, Alvar Aalto Museum, Museum of Finnish Architecture (1239-3401),1, 1997, p. 3-5

Radovic M. Darja, *Modern Architecture in Croatia 1930's*, Zagreb:Institut za Povijest Umjtnosti - Skolska knjiga, 2007

Ray Nicholas, *Alvar Aalto*, Yale University Press New Haven and London Editorial, 2005

Reed Peter, *Alvar Aalto. Between Humanism and Materialism*.The Museum of Modern Art, New York, 1998

Sandoval José María Jove, *Alvar Aalto : Proyectar con la naturaleza*, Valladolid: universidad de Valladolid, secretariado de publicaciones e intercambio Editorial, 2003

Schildt Göran, *Alvar Aalto, The Architectural drawings of Alvar Aalto : 1917-1939*, Garland; 1994 (Schildt, 1994a)

Schildt Göran, *Alvar Aalto in his own words*, Otava Publishing Company, Ltd., Helsinki, 1991 (Ed.1997). (Traducción al español: "Alvar Aalto de palabra y por escrito", El Croquis Editorial, Madrid, 2000)

Schildt Goran, *Alvar Aalto: The Complete Catalogue of Architecture, design and art*, Rizzoli International Publications, Inc., New York, 1994 (Shildt,1994)

Schildt Goran, *Alvar Aalto:The Early Years*, Rizzoli International Publications, Inc., New York, 1984

Schildt Goran, *Alvar Aalto:The Decisive Years*, Rizzoli International Publications, Inc., New York, 1986

Schildt Goran, *Alvar Aalto:The Mature Years*, Rizzoli International Publications, Inc., New York, 1991

Schildt Goran, *Sketches Alvar Aalto*, The MIT press Cambridge, Massachusetts and London, 1978

Shulz Norberg Christian, *Phenomenon of Place*, Architectural Quarterly 8, no 4, 1976, 3- 10, Reprinted in Nesbitt, *Theorizing a New Agenda of Architecture*, 414. *Intentions in Architecture* , Cambridge: Massachusetts: MIT Press, 1965

Siren Heikki, Pietila Reima, *Arquitectura finlandesa en Otaniemi: Alvar Aalto*, Ediciones Poligrafa SA, 1967

Srkulj Stjepan, *Zagreb u prošlosti i sadašnjosti (1.ed)*, Opstina grada Zagreba, 1928

Srkulj Stjepan, *Zagreb in past and present (2.ed)* ,City of Zagreb, 1930

Tobler Waldo, *A computer movie simulating urban growth in the Detroit region*, Economic Geography, 1970.

Voyce Arthur, *Russian Architecture: Trends in Nationalism and Modernism*, Greenwood Publishers, 1969

Zevi Bruno, *Saber ver la arquitectura, Ensayo sobre la interpretación espacial de la arquitectura*, Ed. Poseidón, Barcelona, 1981.

Zuazua B Fernando, *Alvar Aalto. Visiones Urbanas*, Angel Fernandez Alba Arquitectos Asociados, Madrid, 1999.

Weston Richard, *Alvar Aalto*, Phadon Press, London, 1995

Wilkens Michael, *Architektur als Komposition, 10 lektionen zum Entwerfen La arquitectura como composición 10 lecciones para proyectar-* Birkhausser- verlag fur Architektur, 2000

Wilson Colin St John, *Other Tradition of Modern Architecture: The uncompleted Project*, Academy Edition, London, 1995

ANNEX

A1. DESCRIPTION OF THE COMPETITION ENTRY FOR THE
HOSPITAL COMPLEX OF ZAGREB, YUGOSLAVIA ,1930-31

-Alvar Aalto –

source: Archive of Alvar Aalto

STIFTUNGS- UND KLINISCHES KRANKENHAUS
 ZAGREB

GENERAL-BAUPLAN DES STIFTUNGS- UND KLINISCHEN KRANKENHAUS
 ZAGREB

SUD' N^o

WIRTSCHAFTSGEBÄUDE

Das Gebäude liegt auf einem steilen Abhang und ist daher in seinen Stockverlehnungen gewissenhaft auf den Kopf gestellt in Bezug auf die Programmbestimmungen.

In direkter Tunnelverbindung auf dem Niveau des Tunnelganges stehen: Küche, Wäscherei, Desinfektion und Entgegennahme des Kleidermagazins. Dem Tunnel seitlich und von unten her verbunden sind: Elektrizitätswerk und Maschinenräume.

Küche und Wäscherei sind so angelegt, dass in ihnen die Möglichkeit besteht zu Circulatorenbetrieb und rationalisierter Benutzung.

Krankenschwefelräume: 80 % nach Süden.

In ruhigen Stufen haben sie einen eigenen Garten mit einer Kapelle.

Der Verfasser hat keine Konflikte zwischen technischen und gestalterischen Gesichtspunkten gesucht. Als Hauptziel wurde ein natürliches Parksystem angestrebt, das auf richtige Weise die verschiedenen Gebäudekomplexe gleichzeitig umschleudert und trennt und als Ganzes eine natürliche Krönung auf der die Stadt beherrschenden Achse bildet.

STIFTUNGSKRANKENHAUS
 ZAGREB

STIFTUNGSKRANKENHAUS
 ZAGREB

Anordnung von Aufstiegen oder seitlichen Beförderungsmitteln, die nicht über Treppentritte (oder Liftanlagen) führen können.)

Der Tunnel verbindet alle Krankenzavilone miteinander (ausser der psychiatrischen Klinikavilone). Krankenfahrstuhl, Essenfahrstuhl und Wäschefahrstuhl führen von allen Abteilungen aus bis in den Tunnel.

Essen und Kleidung werden im Tunnel mittels Motorrollwagen befördert. Für jede Abteilung in geschlossenen Metallkäben, die in den Fahrstuhl passen.

Der Tunnel gestattet einen direkten Verkehr vom Fundamentniveau des Aufstiegsgebäudes, der Küche, der Wäscherei, der Desinfektionskammer und des Kleidermagazins aus.

STIFTUNGSKRANKENHAUS

Die Aufnahme- und die Ambulanzabteilung sowie die übrigen allgemeinen Abteilungen des Krankenhauses bilden ein gemeinsames Baugebäude für das ganze Krankenhaus. Innerhalb des von diesem Baue geschlossenen Hofraumes ist der Garten gelegen, dessen Niveau höher liegt. (Natürlicher Anstieg des Terrains. Das System ist mit minimalen Schichtsträngen durchgeführt.)

Die Krankenzavilone erheben sich in diesem Garten als zweistöckige Gebäude.

Jeder Pavillon hat zwei Eingänge oder Haupt- und Reservetritte sowie Zugang zum eigenen Park.

Die Operationsäle liegen hauptsächlich nach Norden, teilweise nach Osten und Westen. Auch alle der in den Stockwerken gelegenen Operationssäle haben sowohl Decklicht wie auch Seitenlicht.

Die Kliniken sind in der Regel in Gruppen angeordnet, die durch einen zentralen Korridor verbunden sind. Die Kliniken sind in der Regel in Gruppen angeordnet, die durch einen zentralen Korridor verbunden sind. Die Kliniken sind in der Regel in Gruppen angeordnet, die durch einen zentralen Korridor verbunden sind.

STANDARDÜBERSICHT

Die Kliniken sind in der Regel in Gruppen angeordnet, die durch einen zentralen Korridor verbunden sind. Die Kliniken sind in der Regel in Gruppen angeordnet, die durch einen zentralen Korridor verbunden sind. Die Kliniken sind in der Regel in Gruppen angeordnet, die durch einen zentralen Korridor verbunden sind.

KLINISCHES KRANKENHAUS.

Die Autorien am Ende der Kliniken blicken auf den Zentralteil des Krankenhauses.
 Glatte Aulorien mit abwechselnd Dächern, Mittere nicht.

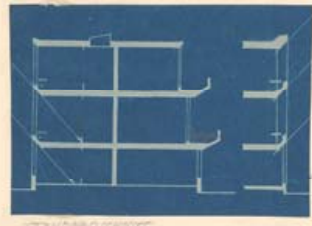

EHEINES.

STANDARDÜBERSICHT.

Jede Krankenzustellung hat ein Zentralkorridorsystem. Die 4 m breiten Zimmerlamellen der Arbeitszimmer auf der Nordseite des Korridors schließen verstellbare Glaswände vom Korridor ab.
 Der Standardquerschnitt zeigt das Isolierverriegelungssystem des Lichtschirms (die Fenster sind höher als die Deckengrenzen). Dasselbe System ermöglicht tiefe Krankenzimmer. Bei weniger tief angelegten Krankenzimmern ist dieses System nicht zur Anwendung gekommen, und kann auch betreffs der verglasten als alternativer Vorschlag angesehen werden.